



US006579391B1

(12) **United States Patent**
Shiffler et al.

(10) **Patent No.:** **US 6,579,391 B1**
(45) **Date of Patent:** **Jun. 17, 2003**

(54) **METHOD FOR FOAM BONDING OF SPUNLACE FABRIC TO PRODUCE ENHANCED FABRIC CHARACTERISTICS**

(75) Inventors: **Donald A. Shiffler**, Kinston, NC (US);
Amit Shahani, Raleigh, NC (US);
Thomas F. Gilmore, deceased, late of Raleigh, NC (US), by Kerry L. Gilmore, legal representative executor

(73) Assignee: **North Carolina State University**, Raleigh, NC (US)

(*) Notice: Subject to any disclaimer, the term of this patent is extended or adjusted under 35 U.S.C. 154(b) by 0 days.

(21) Appl. No.: **09/232,347**

(22) Filed: **Jan. 15, 1999**

(51) **Int. Cl.**⁷ **D04H 5/02**; D04H 5/04; D04H 1/48

(52) **U.S. Cl.** **156/78**; 156/148; 156/181; 204/109; 28/104

(58) **Field of Search** 156/148, 181, 156/78; 28/103, 104; 264/109; 427/421, 424

(56) **References Cited**

U.S. PATENT DOCUMENTS

4,199,644 A * 4/1980 Platt 428/300

4,416,936 A * 11/1983 Erickson et al. 428/286
4,499,139 A 2/1985 Schortmann
4,562,097 A * 12/1985 Wlater et al. 427/209
4,623,575 A 11/1986 Brooks et al.
5,009,747 A 4/1991 Viazmensky et al.
5,252,386 A * 10/1993 Hughes et al. 428/224
5,311,389 A * 5/1994 Howey 360/133
5,405,650 A * 4/1995 Boulanger et al. 427/261
5,475,903 A * 12/1995 Collins 28/104
5,895,623 A * 4/1999 Trokhan et al. 264/504

* cited by examiner

Primary Examiner—Sam Chuan Yao

(74) *Attorney, Agent, or Firm*—Jenkins & Wilson, P.A.

(57) **ABSTRACT**

A method for hydroentangling a nonwoven web to increase the strength and abrasion resistance while maintaining highly desirable hand and drape characteristics. The method provides for carding and cross-lapping synthetic and/or natural fibers so as to form a desired substrate. The substrate is then hydroentangled under relatively low pressure to form a desired spunlace web, and a relatively low amount of a foam adhesive latex binding material is applied to the spunlace web. Thereafter, a force is applied to the foamed spunlace web so as to cause the foamed binding material to fully penetrate the spunlace web from face to back. The resulting hydroentangled (spunlace) nonwoven web provides an enhanced balance of tensile properties, abrasion resistance, and fabric aesthetics.

20 Claims, 23 Drawing Sheets

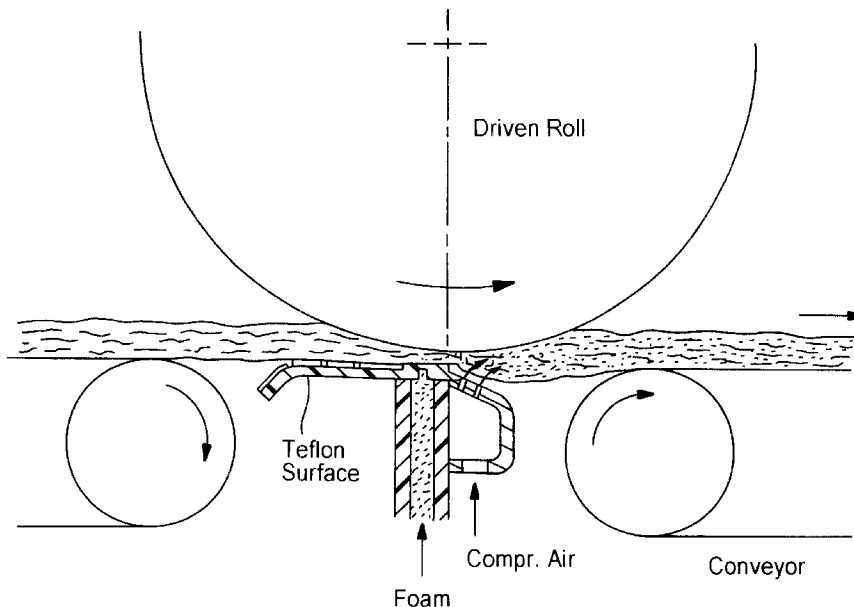

Foam Applicator Mechanism