



## Replacement of VVER-440 Reactor-coolant-pump Main-flange Packing

Karel Pochman<sup>1</sup>, Lubomir Charvat<sup>1</sup>, Ales Licka<sup>2</sup>

1) Nuclear Power Plant Dukovany, Czech Republic

2) Brno University of Technology, Brno, Czech Republic

### Abstract

Reactor Coolant Pump (RCP) of the VVER-440 nuclear power plant is a vertical centrifugal pump equipped with a mechanical gland, electric drive and auxiliary systems. Up to now, its thrust flange is sealed by a flat metal (austenitic) packing which is situated in the main force flow and forms a cover of the pump.

In the working condition, the RCP flange joint is exposed to a force and thermal load action. The force load covers the media internal overpressure effect and forces in stud-bolts. The thermal load results from a temperature distribution in the pump wall (stationary and non-stationary thermal field), eventually it may be caused by parts which have dissimilar thermal expansivity and which can't dilate freely.

Computing fatigue damage cumulations performed after 10 years of operation at Unit 1 of NPP Dukovany in the mostly stressed parts of the thrust cover and the RCP-casing flange showed out values ranging from 0.908 to 3.49. The results evidenced definitely that it was necessary to take actions which would reduce the tenseness in critical parts of the RCP flange and cover. We've chosen an option to modify the seating face so that we could separate the shape stress concentration from the edge stress concentration through a recess machined in the face, which would enable to remove the stress raiser. It was necessary to design its shape so that it would resolve the problem of the reduced life-time and, at the same time, it would be possible to realize the modification right in the power plant.

Furthermore, we've looked for a method of reduction of the tightening forces in the stud-bolts which cause a plastic deformation of the sealing-surface material (for the austenitic packing it is 1180 kN per 1 stud-bolt).

A new flange-joint packing (located in the main force flow) has been designed - a graphite ridge-shaped packing consisting of a steel core with grooves machined in its both surfaces (so called ridges), and foils (with a thickness of 0.75 mm) made of expanded graphite which are pressed into the ridges. This packing is seated at a wider surface of the pump casing than it was in case of the original austenitic packing. Calculations have been made according DIN 2505 and EN 1591 standards in order to check a pressure in the packing at all possible load cases. In sum, 31 stress fields for 31 stress conditions have been calculated.

The calculations have demonstrated that the newly designed ridge-shaped packing together with the graphite foils is capable to assure the tightness of the RCP flange joint while at the same time using significantly reduced tightening forces in the stud-bolts. The newly recommended tightening force is 588 kN compared to the one of 1180 kN used in case of the austenitic packing. This way we happen to reduce significantly the tenseness in the stud-bolts. The reduced tenseness is present also in the pump casing in points where the new packing is installed, thus we achieve an extended RCP service life.

The packing was tested, according to DIN 28090-1 and prEN 13555 standards, at a testing bench at an accredited laboratory in NRI Rez (Nuclear Research Institute). The tests have demonstrated definitely the tightness of the joint with the use of the ridge-shaped packing. It will enable, together with NDT tests performed at the RCP casing (note : no indications found so far), to extend the RCP inspection interval, thus to save the maintenance cost and to reduce radiation doses of the personnel.

Through resolving the RCP main-flange lifetime, NPP Dukovany has become the first and so far the last VVER-type nuclear power plant that has happened to successfully cope with the problem.

### Key words:

Reactor Coolant Pump, life-time, DIALIFE, ridge-shaped packing, STATES-FATIGUE programm.

## 1. INTRODUCTION

A judgment of a residual life-time in the area of the Reactor Coolant Pump's (RCP) main-joint face (main flange) was performed in 1994. With the use of a conservative approach, two areas were identified whose life-time had been used up in the period to a defect initiation – both of them located in the packing position, both at the RCP cover and at the casing, in the area of  $R = 1$  mm radius (see Picture No.1 Overall section of the main flange – on the left, Detail of the packing – on the right) [1].

Based on the end-conditions specification, a repeated judgement was performed. Its results demonstrated that, with the use of the conservative calculating method (stress / deformation dependence - Ramberg-Osgood

type, life-time curve - Manson-Coffin type), based on the number of 9 completed campaigns, the fatigue damage cumulation was higher than 100%.

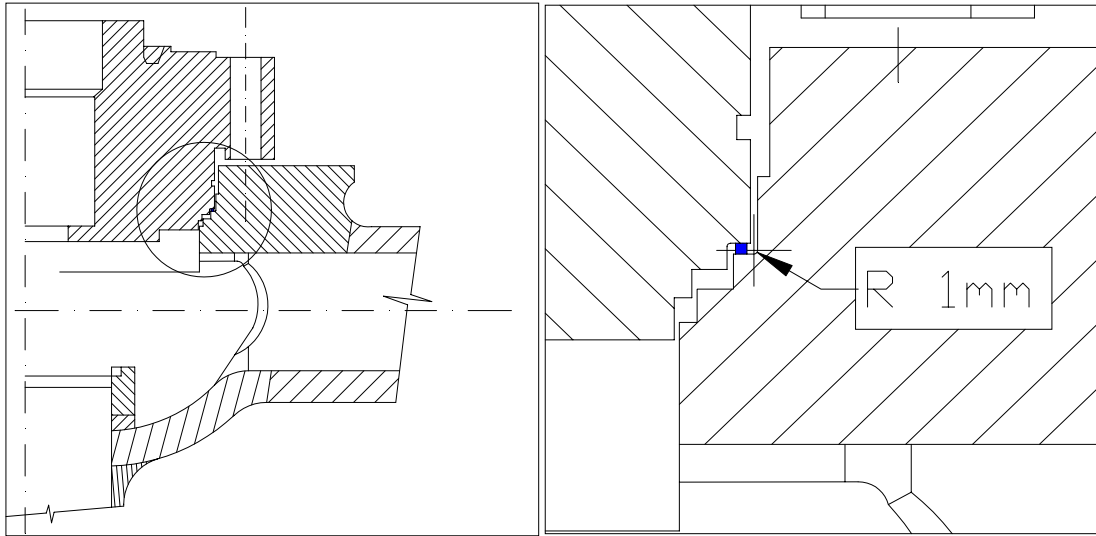

Picture No.1

Based on the information, a work was initiated with the aim of the RCP's life-time extension. Prime attention was paid to a design modification of the main flange which should result in the stress concentration reduction in the critical areas (see Picture No.2). The plant operator's intention was to achieve the stress concentration reduction through a use of a different packing type (Helicoflex) which would be situated in the secondary force flow, with the aim to reduce the tightening forces and stress conditions in the critical areas.

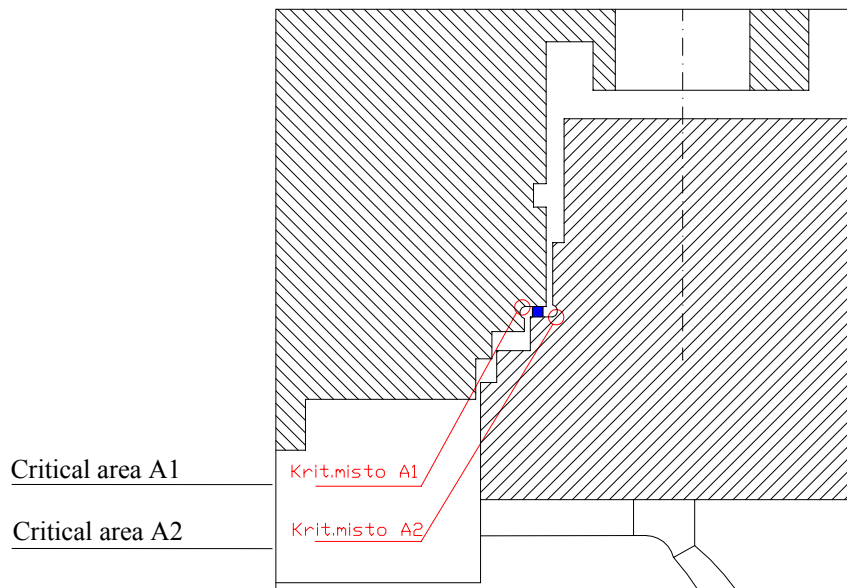

Picture No.2

A number of design modifications were designed at all RCPs, which were to comply with the following requirements :

- a) to reduce the level of tenseness,
- b) to dispose of the layer with the used up life-time,
- c) maximum depth of the repair - 3 mm,
- d) to perform the repair right at the RCP installation.

With regard to the above requirements, relieving recesses in the critical areas A1, A2 (see Picture No.2) were investigated, whose purpose was to separate effects of the shape and edge stress concentrations in the critical points. As it turned out, to reduce the tenseness an increase of the recess' radiuses would be necessary. Furthermore, a contribution of the fatigue damage cumulation in the critical areas of the modified RCPs was determined, either for the austenitic packing and the Helicoflex packing. The cumulation contributions were determined for all operational modes of the reactor unit and were included in the DIALIFE system database. Then calculations of fatigue damage cumulation resulting from the operational modes were performed for the RCP's critical areas after the recess' modification. The idea of the use of the Helicoflex packing was abandoned due to unsuccessful leaktightness tests performed at a 1:1 scale test bench.

## 2. RCP'S CRITICAL AREAS

In the course of year 2001, the relieving recesses in the main flanges of all plant's RCPs were made. From then on, the original austenitic packing has been in use.

Thanks to the above mentioned design modification we have happened to reduce significantly stress in the critical areas A1 and A2 (from 2249 MPa down to 1196 MPa in the linear area). Nevertheless, the life-time use up is higher and higher (which has been demonstrated by calculations).

## 3. Calculating section

The fatigue damage calculations were performed according to A.S.I., Section III methodology. To calculate deformation and stress under the elastically plastic state, Neuber's concept for a consolidated material and Langer-type equations were used. Palgrem-Miner's theory was used as a hypothesis for the damage cumulation.

The damage cumulation calculations were performed for altogether 45 selected stress blocks, for one run of each of them. The blocks had been compiled from the operational modes.

Following computational method was used :

Solidity theory	-	Maximum shear stress
Stress-deformation concept	-	Neuber's
Stress-deformation dependency	-	With a consolidation
Life-time equation (NKU)	-	Langer-type according NTD A.S.I., Section III
Damage cumulation hypothesis	-	Palgrem-Miner theory
Standard in use	-	NTD A.S.I., Section III

### 3.1. Calculation results

The calculation results demonstrate, for example, that from 1997 (when the recesses were made) to 2001 the RCP13's life-time had been used up of 72% and the RCP16's life-time had been used up of 70%. A similar situation had come with RCP42 and RCP43 – 64% and 66% in 2001. The calculations were based on the following assumption – the damage cumulation was 0 (zero) after the relieving recess had been machined.

Picture No.3 shows trends [3] of RCP13's life-time use up since year 1997 when the recesses were made. The picture also represents the date when the respective RCP was put into operation and the total supposed life-time of 30years.

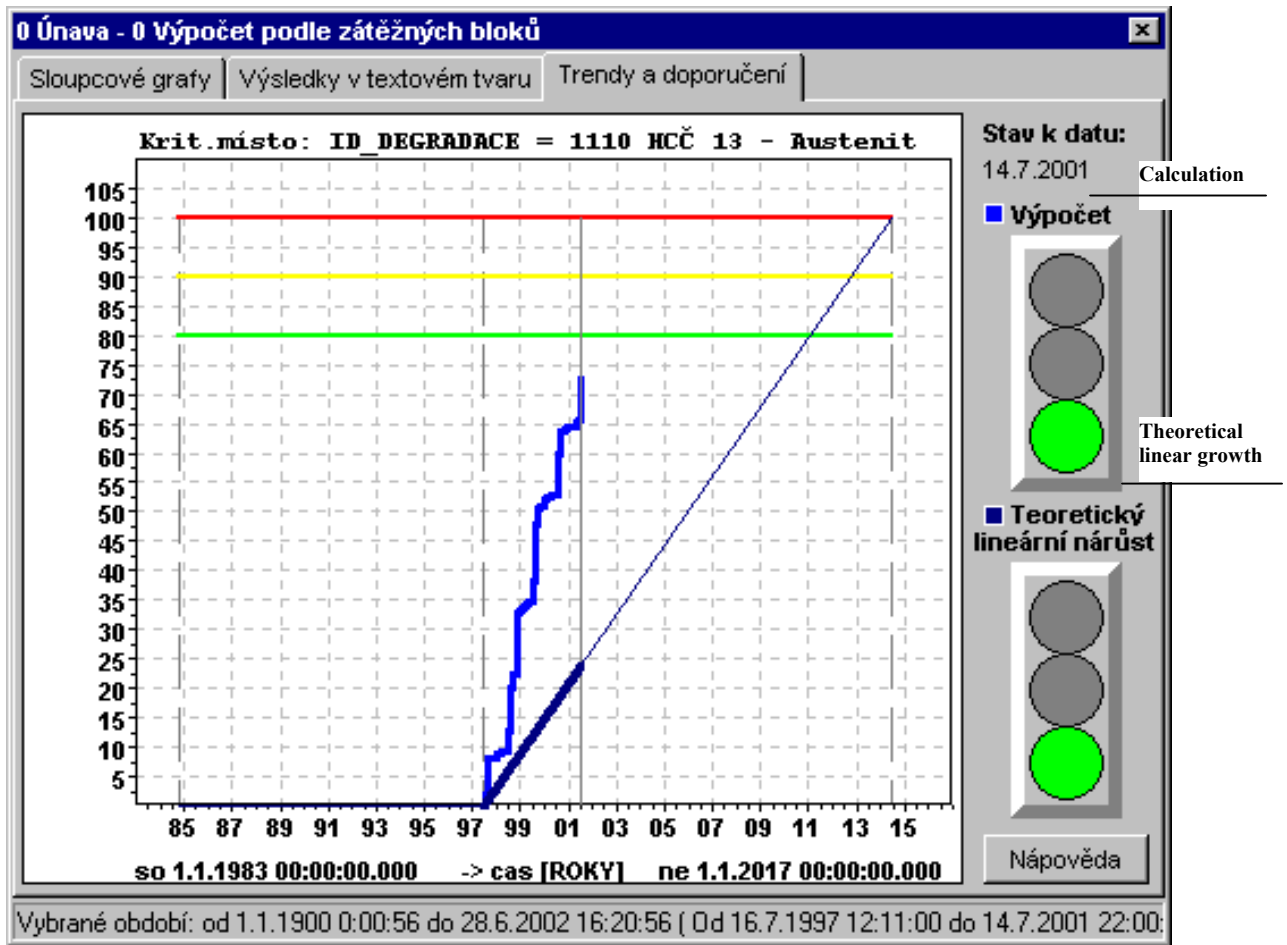

Picture No.3

#### 4. Ridge-shaped packing

Since year 2002, an installation of a new type of packing has begun in Dukovany NPP (see Picture No.5). The new packing is situated in a position called "alternative joint face" in the main force flow where the fatigue damage is demonstrably zero (0). Picture No.4 shows other critical areas M1, M2, M3, and M4, where M2 position corresponds to A1 position and M5 position corresponds to A2 position.

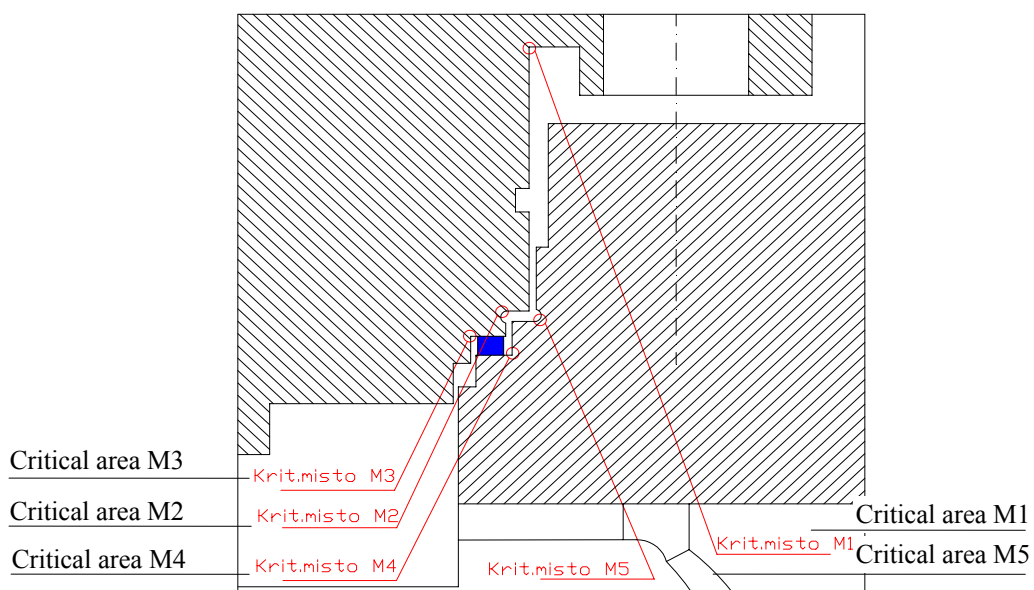

Picture No.4.

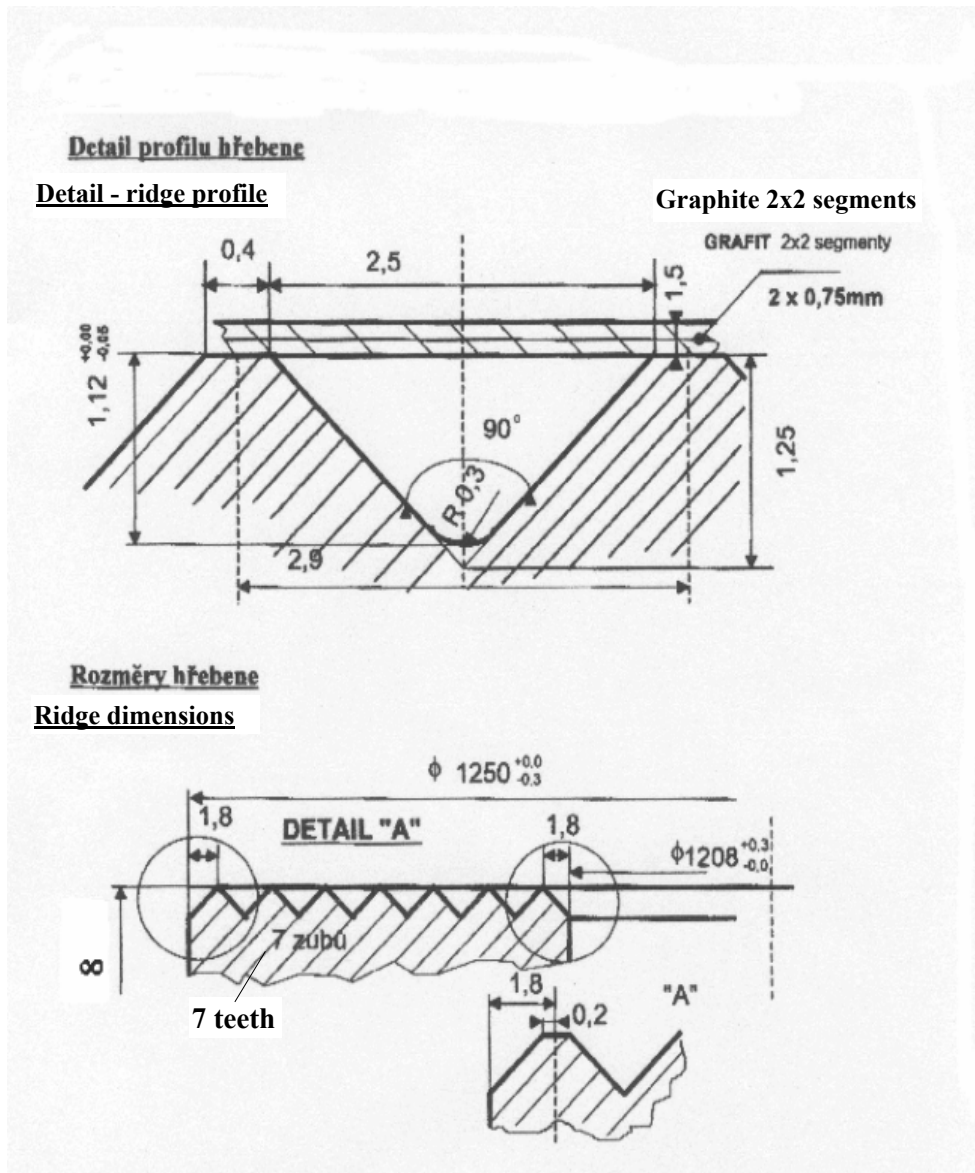

Picture No.5

#### 4.1 Calculation method

The calculations were performed with the use of the Finite Elements Method (FEM). The RCP's cover, shell, packing, and stud-bolts were simulated as common three-dimensional solids. Contacts between the upper surface of the packing and the cover, and between lower surface of the packing and the shell were considered as friction contacts (Coulomb-Orowan friction model). Friction coefficient between steel and graphite  $f = 0.1$ . Similarly considered were contacts between the washers' spheroids and between the upper surfaces of the washers and the nuts. Friction coefficient of the steel-steel combination  $f = 0.2$ . This way more real bending moment values could be calculated for the stud-bolts, as well as altogether more real force and stress conditions in the bolted joint.

When performing the non-stationary calculations, third-class end conditions were considered which are given by the ambient temperature and a heat transfer between the solid surface and the surrounding medium, and resulting heat transport  $\beta$ . Thermal strain and consequent stress calculations were performed for thermal expansion coefficients ( $\alpha$ ) of individual materials.

Stress calculations were performed based on the assumption that Hook's law holds true within the entire range of the load application. When performing calculations of each individual load application condition, a concurrence of all loading effects at the given moment was entered together, using their real values. Due to a nonlinearity of the calculation resulting from the consideration of a contact, the commonly used way of a linear

combination of independently calculated stresses resulting from individual loading effects was not possible. Modulus of elasticity (E) as well as coefficients of thermal expansion ( $\alpha$ ) of individual materials are entered in the mechanical deformation and stress calculations as functions of time (with the exception of the substitutive modulus of elasticity for the packing ( $E_D$ ) and the substitutive modulus of elasticity for the washers ( $E_n$ )).

Calculations of thermal fields and stress fields were performed with the aid of SYSTUS 2000 programme which is based on FEM.

When performing the fatigue damage calculations, A.S.I., Section III, methodology was followed. Neuber's concept of deformation and stress calculations under the elastically plastic state was used and consolidated material and Langer-type equations or, alternatively, stress-deformation Ramberg-Osgood's dependency and Manson-Cofins design life-time curve, were considered. As a damage cumulation hypothesis, Palgrem-Miner's theory was used.

#### 4.2 Material fatigue damage for individual stress blocks

The fatigue damage calculations were performed for altogether 40 selected stress blocks, for one run of each of them. The blocks had been compiled from plant operational modes.

The evaluation is performed based on standards and with the aid of STATES-FATIGUE programme. The first stress block is compiled from the most extremely stress conditions. Only this block is followed by the other blocks. Therefore, hysteretic loops are closed. This was, the material undergoes at first through the biggest hysteretic loops (through the greatest plastic deformations), which to some extent eliminates a certain distortion of the results from the other stress blocks.

Similarly to the previous evaluations, only results of the conservative approach are given here :

Solidity theory	-	Maximum shear stress
Stress-deformation	-	Neuber's
Stress-deformation dependency	-	With a consolidation
Life-time equation (NKU)	-	Langer-type according NTD A.S.I., Section III
Damage cumulation hypothesis	-	Palgrem-Miner theory
Standard in use	-	NTD A.S.I., Section III

For all the calculations, material 08CH18N10T has been considered. The damage cumulations were calculated in locations which are indicated as M1 to M5 in the Picture No.4. The highest damage cumulations were enumerated predominantly in the M4 location.

#### 4.3 Calculation results

The calculations have demonstrated that the newly designed, and currently already used, ridge-type packing with graphite foils is capable to assure the tightness of the RCP flange joint while at the same time using significantly reduced tightening forces in the stud-bolts [2]. The newly recommended initial tightening force, resulting from the calculations, is 588 kN. This corresponds with a tightening of the stud-bolts to the elongation of 0.56 mm (+0.05 mm). It is, therefore, significantly lower than the one of 1180 kN used in case of the previously used austenitic packing. This way we happen to reduce significantly the tenseness in the stud-bolts (therefore, it is not necessary to re-evaluate the stud-bolts).

Fatigue damage contributions from the considered stress blocks will decrease due to the lower tightening force minimally by two orders compared to the current state with the austenitic packing. The highest fatigue damage will be achieved at the position indicated as M4 (see Picture No.6).

The calculations have not demonstrated any disturbance of the joint's tightness at the selected calculating model at any operational mode.

An expected mutual cover-to-shell radial movement between the cold state and the nominal mode is up to 1.3 mm. Therefore, it is necessary to assure that the steel ridge of the packing were made of a material whose coefficient of thermal expansion ( $\alpha$ ) is similar to those of the cover and the shell. The currently used design of the packing meets this requirement. Contact surfaces in the position where the packing is situated must be finely machined.

Sealing properties of the ridge-shaped packing were verified in the course of non-active tests of Unit 2 at NPP Temelin.

## 5. Conclusion

NPP Dukovany has installed DIALIFE system whose functions are to evaluate a gradual damage of materials, to determine a residual life-time, and to process recommendations for a controlled ageing. The system has registered all stress blocks that have occurred at the plant's steam generators, pressurizers, reactor pressure vessels (fatigue), reactor coolant system pipelines, reactor coolant pumps, loop isolating valves, compensatory pipelines, and emergency core cooling pipelines since the commercial start up of individual plant's units (since 1984 at Unit 4).

The damage cumulations that have been calculated for individual RCP's stress blocks have been entered into the DIALIFE system database. Based on this information, calculations for the (so far) latest campaign No. 15 have been performed. A hypothetical use of the new **ridge-shaped** packing was considered at the calculations. Following results have been attained :

Evaluated period – campaign No. 15, from 20/08/1999 to 22/07/2000, RCP11. The highest damage cumulation has been figured out at the M4 position (see Picture No.6) with the numeral identifier IDd = 1275 and a value D = 0.001134, which is possible to formulate as 0.1%, see Picture No.6. This result has demonstrated that the newly installed RCP-main-flange packing has definitely resolved the problem of the reduced life-time.

Note : Bar graphs in Picture No.6 are depicted with the use of a variable scale.

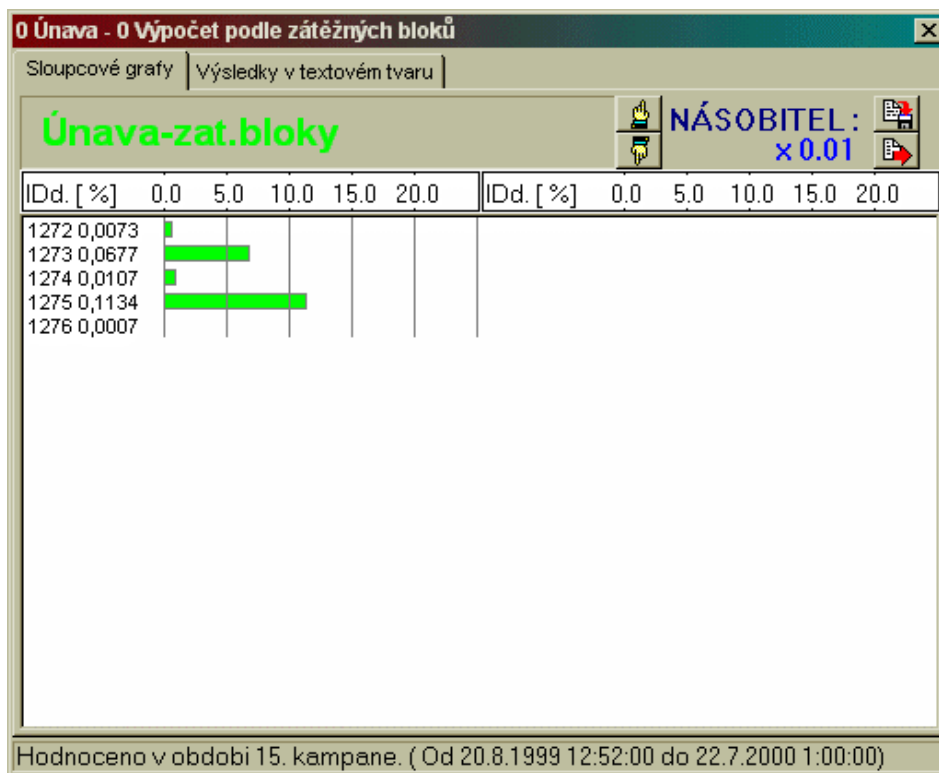

Picture No.6

## References

- [1]Vejvoda, Moulis - RCP sealing face for life-time extension, UTIAM Brno, 1996
- [2]Vejvoda, Vincour, Licka - Residual life-time evaluation of selected VVER 440 components, ( RCP ), UTIAM Brno, 2001
- [3]Vejvoda, Vincour - Residual life-time extension VVER 440 components ( RCP ) UTIAM Brno, 2002