

A COMPARISON OF SIMPLIFIED STRESS-STRAIN RELATIONS FOR IRRADIATED GRAPHITE

J. IRVING,

*Central Electricity Generating Board,
Berkeley Nuclear Laboratories, Berkeley, Glos., United Kingdom*

ABSTRACT

Constitutive laws for graphite are derived from constant stress irradiation creep data. The use of these laws in the stress analysis of creep and Wigner strains is discussed and it is shown that a limiting steady state stress solution will give a reasonable estimate of stresses due to build up of Wigner strains under creep conditions.

1. INTRODUCTION

The Mk. III reactor concept embraces the use of fuel element assemblies manufactured from graphite and graphitic composite materials. These materials suffer large deformations induced by neutron irradiation. In order to determine whether the irradiation induced deformations and the stresses occurring within these reactor components are within design limits it is necessary to be able to carry out a satisfactory stress analysis.

All methods of stress analysis are based on a constitutive law which must be reasonably representative of the actual stress-strain behaviour of the material. This paper is concerned with the derivation of a suitable constitutive law for graphite based on available experimental evidence. As there are some uncertainties remaining in the interpretation of experimental results alternative forms of the uniaxial constitutive law are considered and simplified expressions representing primary creep strain behaviour are derived. Anisotropic three-dimensional constitutive equations are suggested based on the uniaxial derivations. It is shown that under certain conditions a limiting steady state stress solution to the three-dimensional creep problem may be obtained using an associated elastic constitutive law.

An example is given in which a comparison is made between two solutions using alternative forms of the constitutive law and the limiting steady state stress solution. The example shows that, under reasonably steady conditions, there is little difference between the solutions given by the alternative forms of constitutive law and the limiting steady state stress solution.

2. DERIVATION OF UNIAXIAL CONSTITUTIVE EQUATIONS

This derivation is based on constant stress experimental data. The data did not cover the complete ranges of temperature and irradiation dose levels to which graphite may be subjected. However, it has been suggested that by making reasonable assumptions the creep strain response ϵ_c^0 to a constant applied stress σ^0 over an extended range may be adequately

represented by an expression of the following form

$$\epsilon_c^0 = \sigma^0 \left[\frac{1}{E_0} (1 - e^{-k\gamma}) + K\beta(\theta) \int_0^\gamma f(\tau) d\tau \right] \quad (1)$$

where E_0 is the unirradiated static Young's modulus

k and K are constants

$\beta(\theta)$ is a function of θ

θ is the temperature at which test was carried out

$f(\gamma)$ is a function of γ

γ is the neutron irradiation dose

τ is a variable.

The two terms in parenthesis in eq. (1) may be regarded as separate components of the creep strain response, the primary component,

$$\epsilon_p^0 = \frac{\sigma^0}{E_0} (1 - e^{-k\gamma}) \quad (2)$$

and the secondary component,

$$\epsilon_s^0 = \sigma^0 K\beta(\theta) \int_0^\gamma f(\tau) d\tau \quad (3)$$

In addition the Young's modulus may vary with temperature and dose so that the elastic strain component ϵ_E is given by

$$\epsilon_E = \frac{\sigma(\gamma)}{E(\theta, \gamma)} \quad (4)$$

where $\sigma(\gamma)$ is the stress at dose γ

$E(\theta, \gamma)$ is the Young's modulus which is a function of temperature and dose γ .

It can be concluded from the experimental data that, while the secondary creep component given by eq. (3) is not recoverable on removal of stress, it is not clear whether or not the primary component is of similar type. We will now examine the significance of this unknown behaviour of the primary component.

Let us consider the visco-elastic models shown in Figure 1. The primary creep behaviour has been represented in two ways. Firstly as a dashpot with variable viscosity and secondly as a Kelvin element consisting of a spring and dashpot in parallel. The corresponding strain responses to constant stress σ^0 are shown in Figure 2. It can be seen that both the Maxwellian and Maxwell/Kelvin type models produce similar responses while the stress is maintained. However, when stress is removed, only the Maxwell/ Kelvin type of model shows recoverable primary creep strain. These two alternatives result in different types of constitutive law. It is therefore necessary to know whether or not primary creep recovery occurs. Unfortunately, this question has not been satisfactorily resolved. We must therefore consider that either the Maxwell or Maxwell/Kelvin model is possible and derive their respective constitutive laws.

Let us define the primary creep compliance, $C_p(\gamma)$, as

$$C_p(\gamma) = \frac{\epsilon_p^0}{\sigma^0} = \frac{1}{E_0} (1 - e^{-k\gamma}) \quad (5)$$

We may now consider the two possibilities.

2.1 Recoverable Primary Component

When creep strains are completely recoverable on removal of stress, the recoverable primary creep strain response, $\epsilon_{PR}(\gamma)$, to variable stress, $\sigma(\gamma)$, may be obtained by applying the Duhamel integral to eq. (5) giving

$$\epsilon_{PR}(\gamma) = \int_0^\gamma \sigma(\gamma - \tau) \frac{\partial C_p(\tau)}{\partial \tau} d\tau \quad (6)$$

Substitution of eq. (5) into (6) and addition of the result to (3) and (4) gives the complete uniaxial constitutive equation at constant temperature θ .

$$\epsilon(\theta, \gamma) = \frac{\sigma(\gamma)}{E(\theta, \gamma)} + \frac{k}{E_0} \int_0^\gamma \sigma(\gamma - \tau) e^{-k\tau} d\tau + KB(\theta) \int_0^\gamma \sigma(\tau) f(\tau) d\tau \quad (7)$$

2.2 Non-Recoverable Primary Component

When creep strains are not recoverable on removal of stress, the non-recoverable primary creep strain response, $\epsilon_{PN}(\gamma)$, may be obtained by simple integration,

$$\epsilon_{PN}(\gamma) = \int_0^\gamma \sigma(\tau) \frac{\partial C_p(\tau)}{\partial \tau} d\tau \quad (8)$$

Substitution of eq. (5) into (8) and addition of the result to (3) and (4) gives the complete uniaxial equation at constant temperature

$$\epsilon(\theta, \gamma) = \frac{\sigma(\gamma)}{E(\theta, \gamma)} + \frac{k}{E_0} \int_0^\gamma \sigma(\theta) e^{-k\tau} d\tau + KB(\theta) \int_0^\gamma \sigma(\tau) f(\tau) d\tau \quad (9)$$

3. APPROXIMATE CONSTITUTIVE LAWS

In many problems it may not be possible or convenient to use the complete alternative forms of law given in eqs. (7) and (9). In these cases the equations may be simplified by removing the dose dependence of the primary creep strain component. This is possible since the value of k is sufficiently large so that for practical purposes $C_p(\gamma)$ may be taken as constant and equal to $1/E_0$ for all dose levels greater than the low level of 1×10^{20} n/cm².

The true primary creep compliance, $C_p(\gamma)$, may be replaced by an approximating ramp function $C'_p(\gamma)$, given by

$$C'_p(\gamma) = \frac{1}{\gamma_0 E_0} \{ \gamma H(\gamma) - (\gamma - \gamma_0) H(\gamma - \gamma_0) \} \quad (10)$$

where $H(\gamma)$, $H(\gamma - \gamma_0)$ are Heaviside step functions in which

$$H(\gamma) = 0 \text{ for } \gamma < 0; \quad H(\gamma - \gamma_0) = 0 \text{ for } \gamma < \gamma_0$$

$$H(\gamma) = 1 \quad \gamma \geq 0; \quad H(\gamma - \gamma_0) = 1 \quad \gamma \geq \gamma_0$$

and γ_0 is chosen so that $C_p(\gamma_0)$ may be taken as equal to $1/E_0$.

Substitution of $C'_P(\gamma)$ for $C_P(\gamma)$ in eqs. (6) and (8) gives the corresponding approximate primary strain components $\epsilon'_{PR}(\gamma)$ and $\epsilon'_{PN}(\gamma)$. Thus for $\gamma \geq \gamma_0$,

$$\epsilon'_{PR}(\gamma) = \frac{1}{\gamma_0 E_0} \int_0^{\gamma_0} \sigma(\gamma - \tau) d\tau \quad (11)$$

and

$$\epsilon'_{PN}(\gamma) = \frac{1}{\gamma_0 E_0} \int_0^{\gamma} \sigma(\tau) d\tau \quad (12)$$

Taking the limits as γ_0 tends to zero in eqs. (10) to (12), we have

$$\lim_{\gamma_0 \rightarrow 0} C'_P(\gamma) = \lim_{k \rightarrow \infty} C_P(\gamma) = \frac{1}{E_0} H(\gamma) \quad (13)$$

$$\lim_{\gamma_0 \rightarrow 0} \epsilon'_{PR}(\gamma) = \frac{1}{E_0} \sigma(\gamma) \quad (14)$$

$$\lim_{\gamma_0 \rightarrow 0} \epsilon'_{PN}(\gamma) = \frac{1}{E_0} \sigma(0) \quad (15)$$

The approximate primary strain components are given by eqs. (14) and (15) when the primary compliance may, for practical purposes, be considered constant and equal to $1/E_0$ for all dose levels.

3.1 Recoverable Primary Component

The recoverable primary term $\epsilon'_{PR}(\gamma)$ given in eq. (14) is analogous to the elastic strain, ϵ_E , given in eq. (4), and may be grouped with it to give an effective elastic strain component, ϵ'_E , where

$$\epsilon'_E = \epsilon_E + \epsilon'_{PR} = \frac{\sigma(\gamma)}{E'(\theta, \gamma)} \quad (16)$$

where $E'(\theta, \gamma)$, the effective elastic modulus, is given by

$$\frac{1}{E'(\theta, \gamma)} = \frac{1}{E(\theta, \gamma)} + \frac{1}{E_0} \quad (17)$$

This identity replaces the sum of elastic and recoverable primary strain components in eq. (7) giving the approximate constitutive equation

$$\epsilon(\theta, \gamma) = \frac{\sigma(\gamma)}{E'(\theta, \gamma)} + K\beta(\theta) \int_0^{\gamma} \sigma(\tau) f(\tau) d\tau \quad (18)$$

Eq. (18) may be used to give a limiting primary creep solution for all γ greater than zero. When $\gamma = 0$ there will be two values of elastic strain corresponding to Young's moduli of $E(\theta, 0)$ and $E'(\theta, 0)$, giving the true initial elastic and the limiting primary creep solutions respectively.

3.2 Non-Recoverable Primary Component

The non-recoverable primary component, $\epsilon'_{PN}(\gamma)$, given in eq. (15) is independent of dose. It may therefore be represented in the constitutive equation as an initial internal strain, the magnitude of which would be determined from the elastic solution for $\sigma(0)$, the stress at

the beginning of irradiation.

While this gives a satisfactory solution in problems where internal strains are absent at $\gamma = 0$ it will not be realistic when these strains are present. It is probably better in such cases, to group primary and secondary creep components together and use eq. (9).

4. MULTIAXIAL CONSTITUTIVE EQUATIONS

Graphite and graphite composite materials are manufactured either by pressing or extrusion. The manufacturing process gives rise to anisotropic material properties which are symmetrical about the axis of pressing or extrusion. Any multi-axial constitutive law should take account of this anisotropic behaviour.

Let us assume that the anisotropic three dimensional stress-strain behaviour is related to the uniaxial creep response through a matrix of constant coefficients. The alternative forms of multi-axial constitutive laws corresponding to eqs. (7), (9) and (18), including Wigner (irradiation induced) and thermal strains, will be given by

$$\epsilon_{ij}(x, \gamma) = M_{ijkl} S_{kl}(x, \theta, \gamma) + \epsilon_{ij}^{\alpha}(x, \gamma) + \epsilon_{ij}^W(x, \gamma) \quad (19)$$

where x represents the triplet of orthogonal, rectangular coordinates x_1, x_2, x_3

$\epsilon_{ij}(x, \gamma)$ is the strain tensor,

$\epsilon_{ij}^{\alpha}(x, \gamma)$ is the thermal strain tensor,

$\epsilon_{ij}^W(x, \gamma)$ is the Wigner strain tensor,

M_{ijkl} is a matrix of constant coefficients determined by experiment

i, j, k, l range over the integers, 1, 2, 3 and summation over repeated suffixes is implied.

In the above equation $S_{kl}(x, \theta, \gamma)$ represents the right hand sides of eqs. (7), (9) or (18), whichever is required, with $\sigma(\gamma)$ replaced by the stress tensor $\sigma_{kl}(x, \gamma)$.

The alternative forms of constitutive law represented by eq. (19) may be used to solve problems of stress analysis in three dimensions. Because of the dependence on dose and temperature of most properties it is not possible, except in the simplest of problems, to obtain closed form solutions and numerical methods must be used. Numerical solutions can be obtained using the finite element method of elastic analysis (Clough [1]) combined with a finite difference solution of the time or dose dependent creep behaviour. These methods have already been used in problems of creep of isotropic materials such as metals and concrete (Zienkiewicz [2]; Rashid and Rockenhauser [3]; Carmichael, Hornby and Irving [4]) and can be extended to the anisotropic behaviour of graphite (Chang and Rashid [5]). Most of these numerical methods, because of computer storage limitations, are restricted to the non-recoverable Maxwellian creep behaviour alone as characterised by eq. (9) and do not allow Maxwell/Kelvin behaviour to be solved. However, use of the effective elastic modulus derived in eq. (17) enables reasonably accurate solutions to be obtained by these same methods when the recoverable primary component of Maxwell/Kelvin behaviour is required.

5. STEADY STATE SOLUTIONS

Numerical creep analysis can be used to compute stress and strain histories in complex geometries under continuously varying reactor conditions. Frequently, however, the designer requires a good estimate of peak stress under several idealised reactor conditions such as

start-up, operation and shut-down. When this is the case a steady state calculation may be useful in the estimation of operational and shut-down stresses since creep computations are avoided.

We may rewrite eq. (19) using either eq. (9) or (18) as the substitution for $S_{kl}(x, \theta, \gamma)$ and differentiating with respect to dose.

We have, from eqs. (9) and (19) and ignoring the primary term,

$$\frac{\partial}{\partial \gamma} \{ \epsilon_{ij}(x, \gamma) \} = M_{ijkl} \left[\frac{\partial}{\partial \gamma} \left\{ \frac{\sigma_{kl}(x, \gamma)}{E(\theta, \gamma)} \right\} + \sigma_{kl}(x, \gamma) \{ K\beta(\theta) f(\gamma) \} \right] + \frac{\partial}{\partial \gamma} \{ \epsilon_{ij}^w(x, \gamma) \} + \frac{\partial}{\partial \gamma} \{ \epsilon_{ij}^a(x, \gamma) \} \quad (20)$$

and from eqs. (18) and (19)

$$\frac{\partial}{\partial \gamma} \{ \epsilon_{ij}(x, \gamma) \} = M_{ijkl} \left[\frac{\partial}{\partial \gamma} \left\{ \frac{\sigma_{kl}(x, \gamma)}{E(\theta, \gamma)} \right\} + \sigma_{kl}(x, \gamma) K\beta(\theta) f(\gamma) \right] + \frac{\partial}{\partial \gamma} \{ \epsilon_{ij}^w(x, \gamma) \} + \frac{\partial}{\partial \gamma} \{ \epsilon_{ij}^a(x, \gamma) \} \quad (21)$$

As mentioned earlier k is large so that, from the result given in eq. (15), we may ignore the primary term in the derivation of eq. (20) for doses greater than 1×10^{20} n/cm². Let us assume that the dose is given by

$$\gamma = \int_0^t \phi(x, t) dt \quad (22)$$

where $\phi(x, t)$ is the neutron flux distribution which is a function of position x , and time, t . Eq. (20) may now be expressed in terms of the time giving,

$$\frac{\partial}{\partial t} \{ \epsilon_{ij}(x, t) \} = M_{ijkl} \left[\frac{\partial}{\partial t} \left\{ \frac{\sigma_{kl}(x, t)}{E(\theta, \phi, t)} \right\} + \sigma_{kl}(x, t) \phi(x, t) K\beta(\theta) f(\theta, t) \right] + \frac{\partial}{\partial t} \{ \epsilon_{ij}^w(x, t) \} + \frac{\partial}{\partial t} \{ \epsilon_{ij}^a(x, t) \} \quad (23)$$

Where, for example, $E(\theta, \phi, t)$ is the same property as $E(\theta, \gamma)$ but is a new function of the new variables. Eq. (21) may be similarly rewritten.

Now, suppose that at a time t_s the material properties, temperatures, flux distribution, applied strain rates and the body and boundary forces acting on the body are all assumed to remain constant at their values at that time. Under these conditions when all terms of $\frac{\partial}{\partial t} \{ \sigma_{kl}(x, t) \}$ are zero then all $\sigma_{kl}(x, t)$ will take stationary values and will represent the maximum or minimum values of stresses attainable under steady conditions.

Under these conditions eq. (23) becomes

$$\epsilon_{ij}^*(x, t_s) = M_{ijkl} \sigma_{kl}(x, t_s) \phi(x, t_s) K\beta(\theta) f(\theta, t_s) + \epsilon_{ij}^{*w}(x, t_s) + \epsilon_{ij}^{*a}(x, t_s) \quad (24)$$

where the asterisk denotes the first derivative of the function with respect to time at the time t_s at which the steady state solution is required. Now, consider the elastic constitutive law

$$\epsilon_{ij}^*(x, t_s) = M_{ijkl} \frac{\sigma_{kl}(x, t_s)}{E^s(x, \phi, \theta, t_s)} + \epsilon_{ij}^s(x, t_s) \quad (25)$$

where $\epsilon_{ij}^s(x, t_s)$ represents 'initial' strains (Timoshenko and Goodier [6]). Comparison of eqs. (24) and (25) shows that the steady state stresses and strain rates will be given by an elastic solution using eq. (25) as the constitutive law in which

$$\frac{1}{E^s(x, \phi, \theta, t_s)} = \phi(x, t_s) K\beta(\theta) f(\theta, t_s)$$

and

$$\epsilon_{ij}^s(x, t_s) = \epsilon_{ij}^{*w}(x, t_s) + \epsilon_{ij}^{*\alpha}(x, t_s)$$

and body and boundary forces remain at their values at t_s .

This steady state stress solution will only give limiting stresses and will be related to actual values only when applied strain rates and loads are maintained for a sufficient time period. This condition may occur during periods of continuous reactor operation. In practice, secondary creep rates are sufficiently high for the actual values of stress due to Wigner strains alone to be similar to the limiting steady state values. Thus, by using the associated elastic constitutive law represented by eq. (25) we may obtain a reasonable solution for operational stresses so long as conditions can be assumed to be reasonably constant.

When temperatures change rapidly as in reactor shut-downs the limiting stresses may be found by superimposing the elastic stresses due to the difference between operational and shut-down thermal strains on the limiting steady state stresses. The steady state stress solution will only provide values of strain rates, $\epsilon_{ij}^*(x, t_s)$. Values of strain will not be given.

Although, as was mentioned earlier, several numerical methods of solution of the creep problem are possible, these methods are usually confined to problems which can be reduced to the plane stress/strain or body of revolution type of problem. Truly three dimensional problems while soluble elastically (Carmichael [7]), require prohibitive computer running times for the corresponding creep solution. The steady state associated elastic solution is therefore a reasonable method for calculating stresses in this class of problem.

6. EXAMPLE SOLUTION

In order to compare the effect of using one or other of the constitutive laws given above a typical problem involving applied strain effects was devised. This problem is illustrated in Figure 3. A flexurally restrained beam was assumed to be subjected to the temperature crossfall shown in Figure 3 and Wigner strain distribution which varied with dose as shown in Figure 4. Flux was assumed to be uniform across the beam and all applied strains and properties were constant in the longitudinal direction.

Longitudinal stresses were calculated at a cross-section remote from the ends. Two forms of constitutive laws were used. These are represented by eq. (7) for Maxwell/Kelvin type recoverable primary creep behaviour and by eq. (9) for Maxwellian non-recoverable primary creep behaviour. Solutions were found numerically using the CRAB computer program (Whitwam [8]). This program enables the solutions to be obtained using either the Maxwellian or

Maxwell/Kelvin type constitutive laws including realistic variations of properties with temperature and dose. The steady state limiting stress solution was also found, corresponding to eq. (25), at dose increments of 2×10^{20} n/cm².

The three stress solutions found are shown in Figure 5. The value of stress at zero dose is due to differential thermal expansion and this soon dies away. It can be seen that when the Wigner strain is building up at a reasonably constant rate, the three solutions are practically coincident. When the Wigner strain rate changes sign the alternative creep solutions differ but the maximum value of stress attained is bounded by the steady state solution.

Although this result is for a particular problem it does indicate that where it is known, or it can be assumed, that Wigner strain rates are reasonably constant then a good approximate solution for stresses will be given by the steady state method. It can also be concluded that there will be little difference in the stress solutions for either of the alternative forms of constitutive laws given by eqs. (7) and (9) when Wigner strains are building up at constant rate. The differences only become apparent on reversal of strain rates.

7. CONCLUSIONS

Constitutive laws for graphite have been derived from experimental constant stress irradiation creep data. Uncertainties in the interpretation of the primary creep data have been resolved by considering that either of the two extremes of recoverable or non-recoverable creep strain behaviour are possible.

Methods of stress analysis using these constitutive laws have been discussed and it has been shown that a limiting steady state stress solution can be obtained by elastic methods of analysis. A comparison of the alternative forms of constitutive law has been made in an example solution. It has been inferred from this example that the steady state solution is a reasonable method of estimating limiting stresses due to the build-up of Wigner strain under creep conditions.

ACKNOWLEDGEMENT

This paper is published by permission of the Central Electricity Generating Board.

REFERENCES

- [1] CLOUGH, R.W., "The finite element in plane stress analysis", Proc. 2nd A.S.C.E. Conf. on Electronic Computation, Pittsburgh, Pa., (1960).
- [2] ZIENKIEWICZ, O.C., The finite element method in structural and continuum mechanics, 1st ed., pp272, McGraw-Hill, London, (1967).
- [3] RASHID, Y.R., ROCKENHAUSER, W., "Pressure vessel analysis by finite element techniques", Proc. Conf. P.C.P.V., Inst. Civ. Engrs., London, (1967).
- [4] CARMICHAEL, G.D.T., HORNBY, I.W., IRVING, J., Correlation of measured and calculated strains in the top half of the Oldbury prestressed concrete pressure vessel R1 for the period 1965 to 1970, C.E.G.B. Report, RD/B/N1784, (1971).
- [5] CHANG, T.Y., RASHID, Y.R., "Viscoelastic reponse of graphitic materials in irradiation environments", Nucl. Eng. Design 14, 181, (1970).
- [6] TIMOSHENKO, S., GOODIER, J.N., Theory of elasticity, 2nd Ed., pp506, 425, McGraw-Hill London, (1951).
- [7] CARMICHAEL, G.D.T., "The application of three dimensional finite elements to the analysis of podded boiler type prestressed concrete pressure vessels", Nucl. Eng. Design 16, 35, (1971).
- [8] WHITWAM, C.M., Creep and cracking in concrete blocks, C.E.G.B. Report, RD/C/N205, (1968).

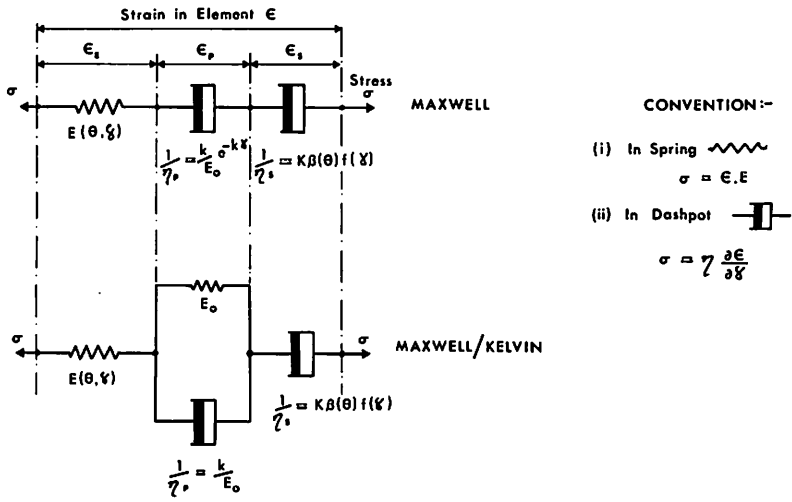

FIGURE 1. ALTERNATIVE VISCO-ELASTIC MODELS DERIVED FROM EXPERIMENTAL STRESS-STRAIN BEHAVIOUR OF GRAPHITE

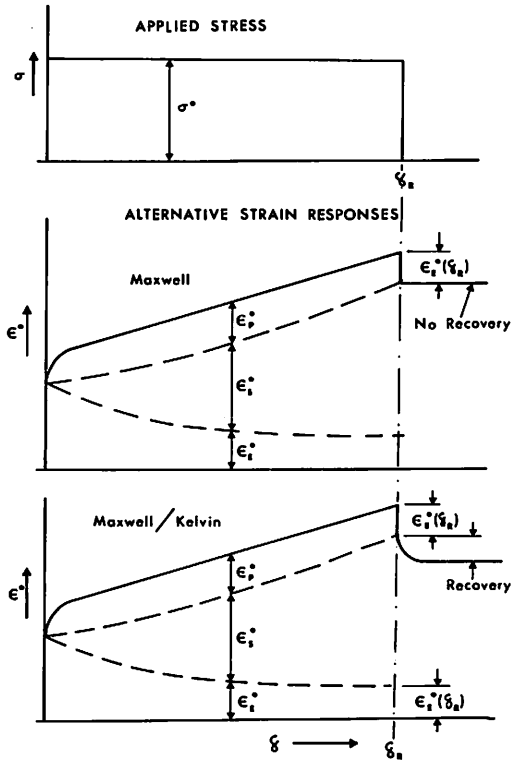

FIGURE 2. STRAIN RESPONSES OF ALTERNATIVE FORMS OF STRESS-STRAIN BEHAVIOUR ON STRESS REMOVAL

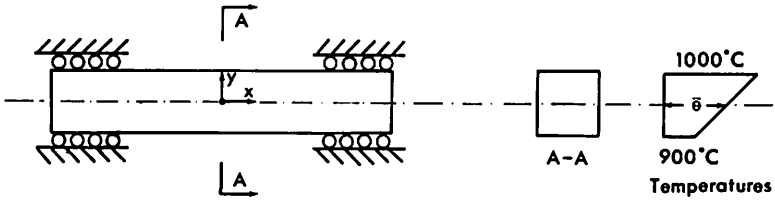

FIGURE 3 . Flexurally Restrained Beam.

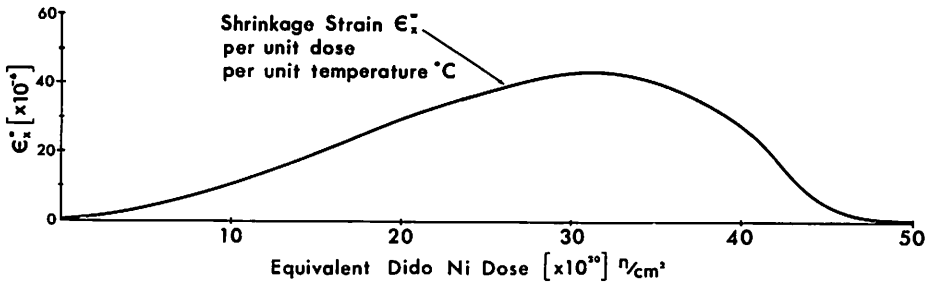

FIGURE 4 . WIGNER SHRINKAGE STRAINS IN BEAM

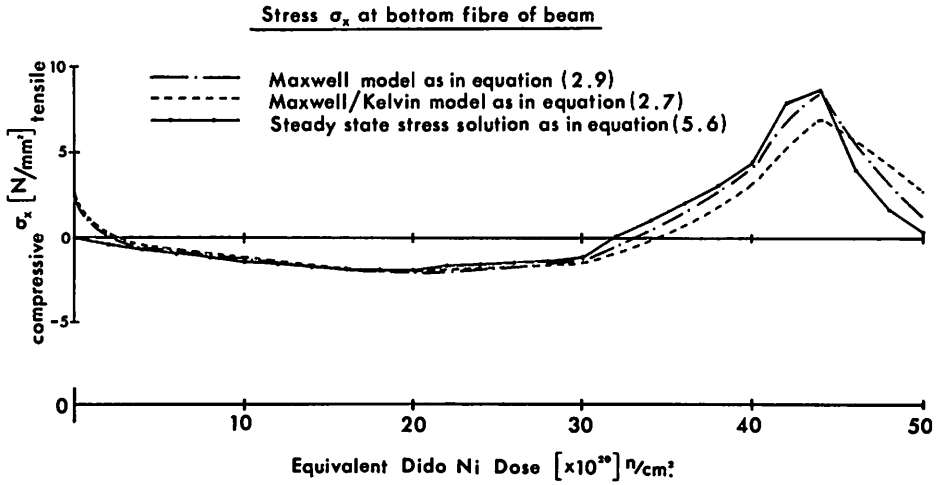

FIGURE 5 . COMPARISON OF STRESSES IN BEAM USING ALTERNATIVE CONSTITUTIVE LAWS

DISCUSSION

A. PHILLIPS, U. S. A.

Q

I observed from one of the figures that there is little difference in the results from the calculations on the basis of the three theories used. I suggest that the problem used is not a suitable one for differentiating between the three theories.

J. IRVING, U. K. p. p. D. J. LEWIS, U. K.

A

The restrained beam has been extensively used as a vehicle for the examination of thermal creep behaviour, both theoretically and experimentally. It is often used for instance in the study of concrete creep. It has many of the important features of a part of a larger structure in that the restraint imposed by the rest of the structure is simulated. The relaxation of thermal stress by creep can be accurately simulated and stress reversals on cooling can be studied. The program CRAB mentioned in the paper uses the restrained beam model for the comparative study of various material behaviour laws. It provides a cheap and rapid way of carrying out these studies before application to more complex shapes.

J. L. HEAD, U. K.

Q

The constitutive equation appears to allow for dose or time dependence of the steady creep strain rate. Is there any experimental evidence of such dose dependence ?

J. IRVING, U. K.

A

I am not aware of published experimental evidence which gives an explicit relationship between secondary creep strain rate and dose. The general integral function was used, because, not only does it make the constitutive law more general but, also, because the behaviour of other material properties suggests that some change of secondary creep rate may be expected at high dose levels.