

# Recent Development of a Fuel Pin Bundle Mechanical Performance Code "ÉTOILE"-Pin Ovaling Model

Masatoshi Nakagawa

*Nippon Atomic Industry Group Company, Ltd., Kawasaki, Japan*

Yasushi Tsuboi

*Toshiba Corporation, Yokohama, Japan*

## ABSTRACT

"ÉTOILE" is a 3-D FEM code for the prediction of the fuel pin bundle distortions and mechanical behaviors during irradiation in LMFBR cores. The numerical model and the results of validation study of the code with the data of the bundle compression test have been reported at SMiRT 7 (Nakagawa,1983), SMiRT8 (Nakagawa,1985) and SMiRT9 (Nakagawa,1987).

In some examples of highly irradiated fuel pin bundles, pin ovalization due to pin bundle-duct mechanical interaction has often been observed (Dupouy,1982) (Leclere et al,1984). The objective of this paper is to report how the code ÉTOILE has been improved to have the ability of treating pin ovaling taking into account of nonlinear creep.

## 1. INTRODUCTION

It is known that the wire-wrapped rods and the hexagonal duct of the LMFBR fuel assembly undergo gradual structural distortion due to the combined effects of thermal expansion and irradiation induced swelling and creep. Because of the higher temperature in the fuel pin bundle than in the hexagonal duct wall, the fuel pin bundle will swell faster than the duct. With the increase of neutron irradiation, the contact force between the duct and the bundle will occur. And subsequently this contact force will begin to increase and the clearance between pins and between pins and duct will gradually be taken up (BDI;Bundle Duct Interaction). If the contact force and/or the reduction in clearance between pins do become excessive, potential problems affecting the fuel life time can arise. The determination of the equilibrium configuration of the pin bundle is of high importance, especially from the safety point of view.

For this purpose, we have developed a computer program ÉTOILE. The program predicts, at every time step, three-dimensional displacements of all fuel pins and the interaction forces between pins and between pins and duct. The program has the following features:

- (1) Ability of calculating up to very high burnup ( about 4 dw ; an index indicating the degree of BDI) by means of the newly developed model representing pin dispersion.
- (2) Ability of representing spiral deformations of cladding due to the mechanical interaction between the cladding and spiral wire during irradiation.
- (3) Incorporation of friction effects on the contact points between pins and between pins and duct.

In some examples of highly irradiated fuel pin bundles, pin ovalization due to pin bundle-duct mechanical interaction has often been observed (Dupouy,1982)

(Leclere et al,1984),as well as pin dispersions and cladding spiral deformations. Hence, the program has been improved from the version reported at SMiRT 9 (Nakagawa,1987) to provide with additional function of calculating pin ovalization.

The objective of this paper is to report how the code ÉTOILE has been improved to have the ability of treating pin ovaling taking into account of nonlinear creep.

## 2. CALCULATION MODEL

The derivation of the numerical method to quantify the ovality due to creep relaxation is based on the analytical method proposed by D.P.Chan (Chan et al,1981).

The analytical model of the program is shown in Fig.1. Each single circular pin is considered to be a Bernoulli Euler beam. Each beam is axially subdivided into six or twelve finite elements per one wire turn. Each axial level of nodal points of finite elements is chosen at the level of the pin-wire contact(pinching) plane or the duct-wire contact (normal) plane as shown in Fig.1. Time incremental method is used to analyze the mechanical equilibrium of fuel pin bundles during irradiation. Then the calculations are repeated for each time step from the initial time to the end.

To solve the ovaling deflection of the fuel pin claddings at any time step,the following assumptions are adopted.

- (1) Ovaling occurs under diametrical compression force in the pin-wire contact (pinching) planes of fuel pin bundles (see Fig.1).
- (2) A diametrical compression force is applied to the cladding. The direction and strength of the force are approximated by averaging the two forces loaded from neighboring pins (see Fig.2).
- (3) The compression force is constant within each time step,that is,the force at the beginning of the time step.
- (4) Elastic stiffnesses of cladding and fuel pellet are assumed to be simulated by linear springs (see Fig.3).

Figure 4 shows the ovaling of the cladding cross-section under diametrical compression at the beginning of some time step (i-th time step). Let the deformed shape of the cladding cross-section be an ellipse,and the decrease of the diameter in the compression direction (W) equal to the increase of the diameter in the orthogonal direction. W consists of the elastic deformation (We) and the creep deformation (Wc).

Using the assumption (4), elastic deformation (We) can be written as

$$W_e = \int_0^{F_n} K^{-1} dF_n \quad , \quad (1)$$

where

$$\begin{aligned} K &= K_c && \text{for } W < \delta \quad , \\ K &= K_c + K_p && \text{for } W \geq \delta \quad , \end{aligned}$$

and

$$\begin{aligned} K_c &= \text{compression stiffness of a cladding,} \\ K_p &= \text{compression stiffness of a fuel pellet,} \\ F_n &= \text{compression force.} \end{aligned}$$

Using the assumption of elliptically deformed shape,and applying the virtual work principle, the creep deformation (Wc) at the beginning of i-th time step is obtained by D.P.Chan as

$$W_c = - \frac{4 R_m}{t} \int_{-t/2}^{t/2} r \epsilon_0^c dr \quad , \quad (2)$$

where

- r = distance from the cladding midwall
- t = cladding thickness
- Rm = cladding mean radius
- $\epsilon_0^c$  = creep strain in the hoop direction at the point of compression, at the beginning of i-th time step.

And the stress and strain in the hoop direction at the point of compression, at the beginning of i-th time step, are obtained as

$$\sigma_0 = E (\epsilon_0 - \epsilon_0^c) \quad (3)$$

and

$$\epsilon_0 = \frac{3 W r}{R_m} \quad (4)$$

In the numerical procedure, using equations (3) and (4), the stress at the beginning of i-th time step is calculated. Then the increment of creep strain  $\Delta \epsilon_0^c$  in i-th time step is calculated according to given material law. Thus, for i-th time step, the increment of the creep deformation ( $\Delta W_c$ ) in radial displacement can be obtained as

$$\Delta W_c = - \frac{4 R_m}{t} \int_{-t/2}^{t/2} r \Delta \epsilon_0^c dr, \quad (5)$$

where

$\Delta \epsilon_0^c$  = increment of creep strain in the hoop direction at the point of compression in i-th time step.

### 3. CALCULATION RESULTS

The test calculation was performed for a fuel subassembly containing 37 fuel pins during irradiation of 3 years (see Fig. 5).

The Blackburn equation (Gilbert et al, 1977) was used for thermal creep and the Gilbert-Bates equation (Gilbert et al, 1977) was used for irradiation creep. As the swelling equation the HEDEL MARK 6 equation (Bates et al, 1980) was used.

Figure 6 shows the displacement profiles for a typical axial plane at the end of 3 years. The solid curves show fuel pin cladding shapes and positions after deformation, while broken circles show the initial (no deflection) shapes and positions. The arrows represent the directions of displacement. The elliptical shape of fuel pin cladding indicates the ovaling deflection due to pin bundle-duct mechanical interaction.

### 4. CONCLUSION

From sample calculations, it was confirmed that the improved program is capable of reasonably simulating mechanical behaviors of fuel pin bundle taking into account of creep ovaling deflections during irradiation.

### 5. ACKNOWLEDGEMENT

The author would like to express his grateful thanks to Dr. K. Aoki of NAIG Research Laboratory and Mr. T. Kobayashi of Toshiba Corporation, for their valuable discussions and sustained encouragement.

## REFERENCES

- Bates, J.F. and Korenko, M.K. (1980). Empirical Development of Irradiation-Induced Swelling Design Equations. *Nucl. Technol.*, 48, 303.
- Chan, D.P. and Jackson, R.J. (1981). Creep Relaxation of Fuel Pin Bending and Ovaling Stresses. *Journal of Engineering for Power*, Vol. 103, pp. 621-626, Oct., 1981.
- Dupouy, J. (1982). Rapsodie and Phenix - The materials Story. Effects of Radiation on Materials: Eleventh Conference, ASTM STP 782, pp. 1179-1196.
- Gilbert, E.R. and Blackburn, L.D. (1977). Creep deformation of 20 percent cold worked type 316 stainless steel. *Journal of Engineering Materials and Technology*, April.
- Gilbert, E.R. and Bates, J.F. (1977). Dependence of Irradiation Creep on Temperature and Atom Displacement in 20 Percent Cold Worked Type 316 Stainless Steel. *J. Nucl. Mater.*, 65, 204.
- Leclere, J. and Millet, P. (1984). L'element combustible des reacteurs a neutrons et son comportement. *Annales de Chimie, Fr.*, 9, pp. 423-431.
- Nakagawa, M. (1983). ÉTOILE: A Three-Dimensional Finite Element Code for Analyzing Fuel Pin Deformations in an LMFBR Assembly. *Proceedings 7th SMiRT Conference*, Vol. C, C7/5, Aug..
- Nakagawa, M. (1985). Validation of a Fuel Bundle Mechanical Performance Code ÉTOILE with BDI Experimental Data. *Proceedings 8th SMiRT Conference*, Vol. C, C4/3, Aug.
- Nakagawa, M. (1987). Validation of a Fuel Bundle Mechanical Performance Code ÉTOILE with BDI Experimental Data (II). *Proceedings 9th SMiRT Conference*, Vol. C, pp. 25-30, Aug.

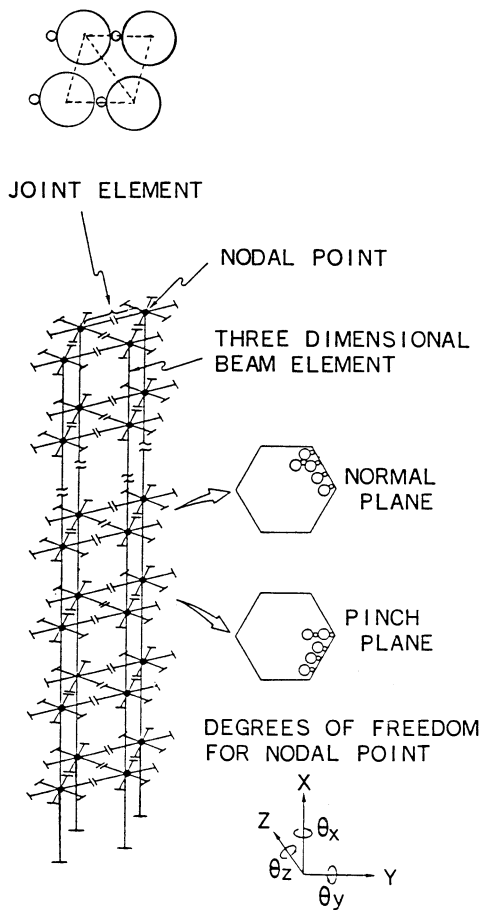

Fig.1 Model of a Fuel Pin Bundle

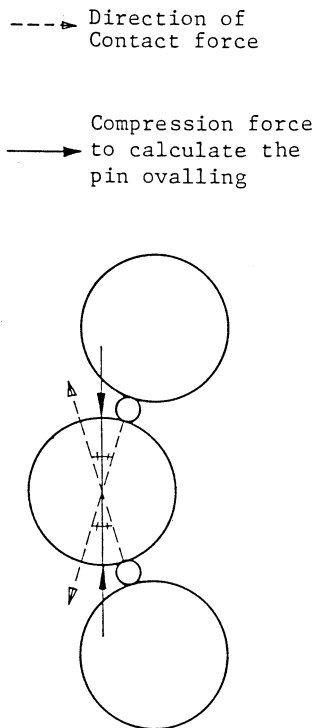

Fig.2 Model of Compression Direction

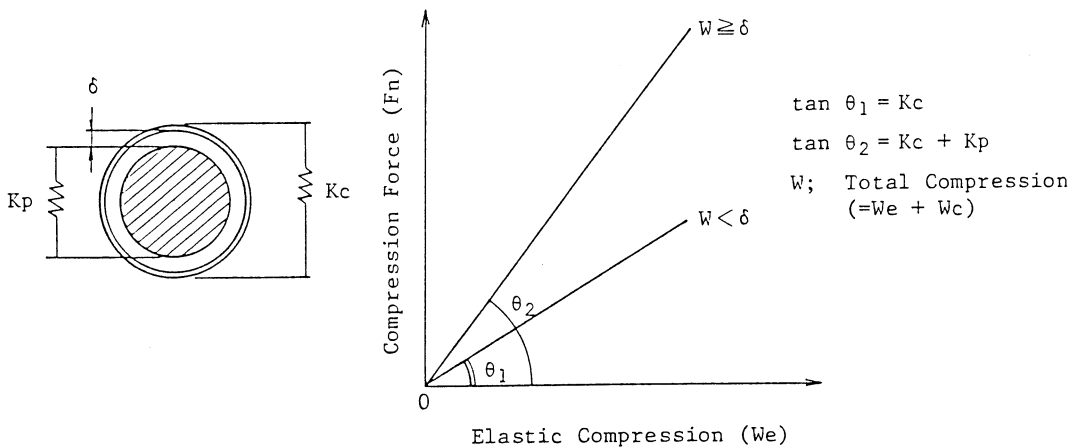
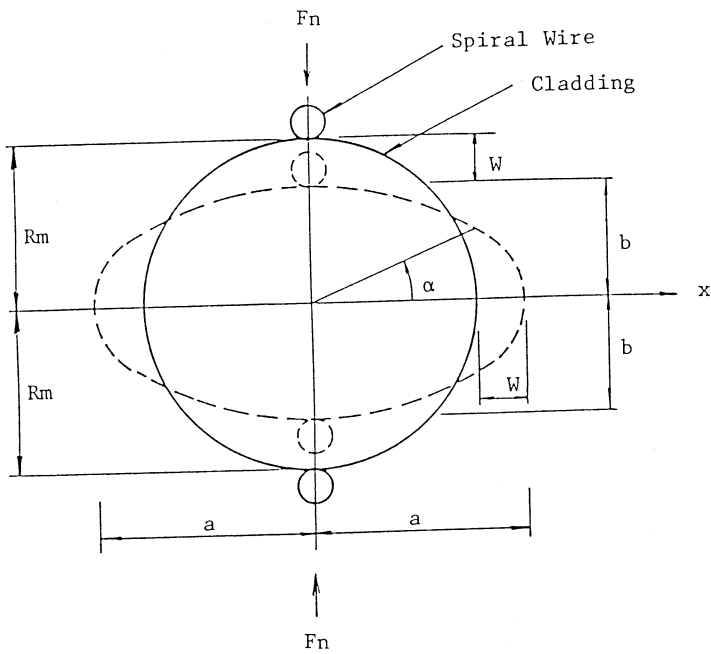
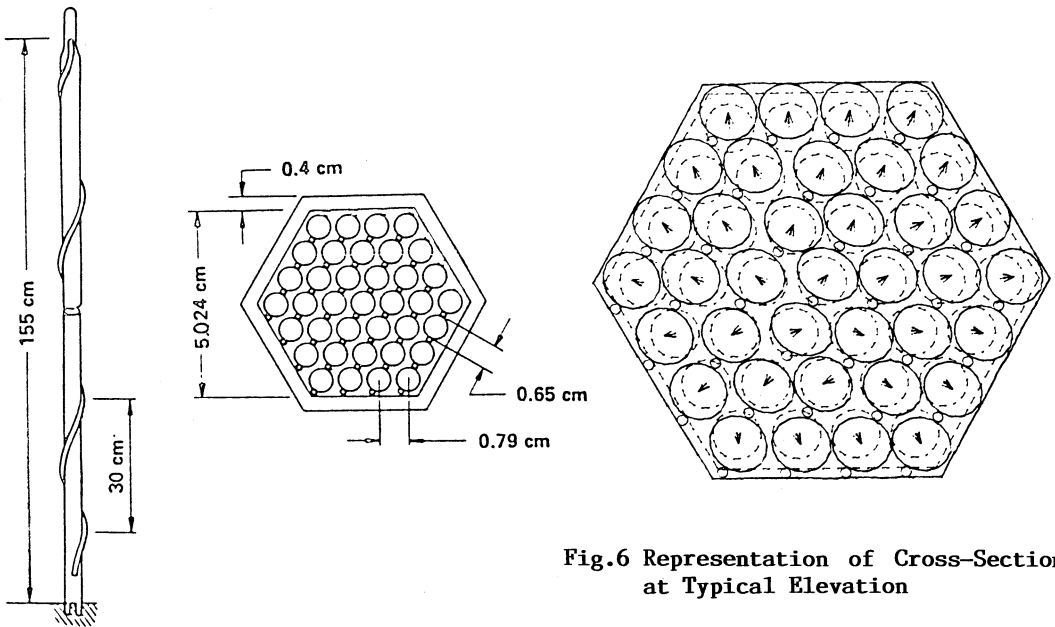

Fig.3 Model of Elastic Stiffness of Cladding and Pellet.



**Fig.4 Owalling of Cladding Cross-Section**



**Fig.6 Representation of Cross-Section at Typical Elevation**

**Fig.5 Configuration of the Calculation Condition**