

---

## DESIGN OF SC COMPOSITE WALLS FOR PROJECTILE IMPACT: LOCAL FAILURE

Jakob C. Bruhl<sup>1</sup>, Amit H. Varma<sup>2</sup>, and William H. Johnson<sup>3</sup>

<sup>1</sup> Graduate Student, School of Civil Engineering, Purdue University, West Lafayette, IN  
(jbruhl@purdue.edu)

<sup>2</sup> Associate Professor, School of Civil Engineering, Purdue University, West Lafayette, IN

<sup>3</sup> Principal Engineer, Bechtel Corporation, Frederick, MD

### ABSTRACT

This paper summarizes a convenient and efficient method to determine the thickness of both concrete and steel components of a steel-plated reinforced concrete (SC) wall to prevent perforation. Experimentally validated equations to calculate the required wall thickness of conventionally reinforced concrete walls (RC) to prevent scabbing and perforation exist and are included in NEI 07-13 and DOE-STD-3014-2006. No such equations currently exist for steel-plated reinforced concrete (SC) walls. There are instead empirical methods based on the works of Morikawa (1997) and Mizuno et al (2005). By expanding the work of Mizuno et al (2005) and combining it with the current provisions in NEI 07-13 and DOE-STD-3014-2006, the authors provide a convenient three-step process to design SC walls to resist projectile impact. The method is presented graphically (for limited applications) and through a series of equations (for broad application). Results from the method presented are compared to experimental test data to confirm its validity.

### INTRODUCTION

SC walls have proven to be extremely efficient for fabrication, erection, and construction of nuclear power plants and are being considered for use on the next generation of Small Modular Reactors. AP1000 and US-APWR both use SC walls for the primary and secondary shield walls within the containment. AP1000 uses an SC shield building outside of the steel containment vessel to provide radiation shielding, earthquake resistance, tornado missile protection and aircraft impact resistance. It is important, therefore, that engineers have a convenient and accurate method to design SC walls to resist impact. Empirical formula and design methodologies to determine the wall thickness for RC walls to preclude failure by any of its perforation, scabbing or penetration limit states (Figure 1) have long been available. These were established during the 1940's for munitions projectiles, and later extended and modified to include the effects of missile deformability (DOE-3014) and low velocity (Degen, 1980). The actual design limit state for RC walls depends on the type of equipment housed within the structure. Because of the risk of damage to internal components, scabbing is the most common design limit state. However, for structurally robust safety-related components which can withstand impact from the spalled particles, the design limit state is perforation. A set of empirical formulas for the RC wall thicknesses needed to preclude the various limit states is given in DOE-3014.

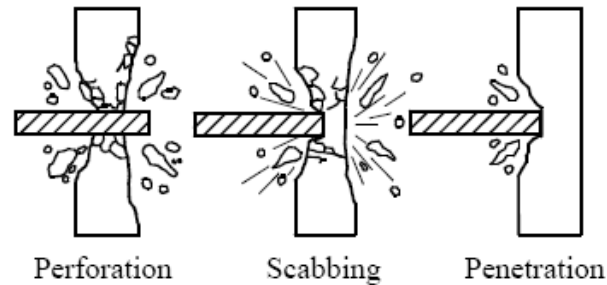

Figure 1 RC Panel Missile Impact Failure Modes (from Hashimoto et al., (2005))

Failure modes of SC walls differ from those for RC walls because the rear steel plate prevents scabbing of the concrete prior to perforation. For SC walls, failure modes include penetration, rear steel plate bulging, rear steel plate splitting, and finally perforating the entire wall (see Figure 2). Because scabbing is limited by the steel plate, the governing limit state for SC walls is typically perforation. This change in limit state leads to a thinner wall to resist missile impact. The capacity gained by combining steel plates and concrete results in an even thinner wall.

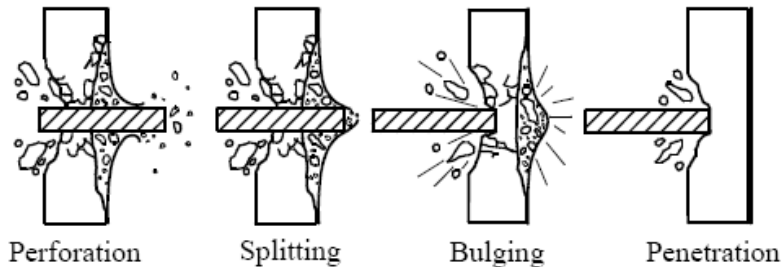

Figure 2 SC Panel Missile Impact Failure Modes (from Hashimoto et al., (2005))

Morikawa (1997) is cited as developing an equation (or method) to design the thickness of a concrete panel with a rear steel plate. His method is adapted by Mizuno et al., (2005) and further improved to account for missile deformability. This paper develops a method for designing SC walls to prevent local failure from missile impacts. It is based largely on the work of Mizuno et al (2005).

## MIZUNO'S EMPIRICAL METHOD

Mizuno et al (2005) provided a graph that depicts a proposed tearing limit of SC panels. This type of graph is very useful as it enables a quick selection of concrete panel thickness for a given impact velocity. As long as a concrete thickness is selected above the line in Figure 3 the design will resist perforation of a missile at the selected impact velocity. For example, for an impact velocity of 150 m/s, the minimum concrete thickness is approximately 60 cm.

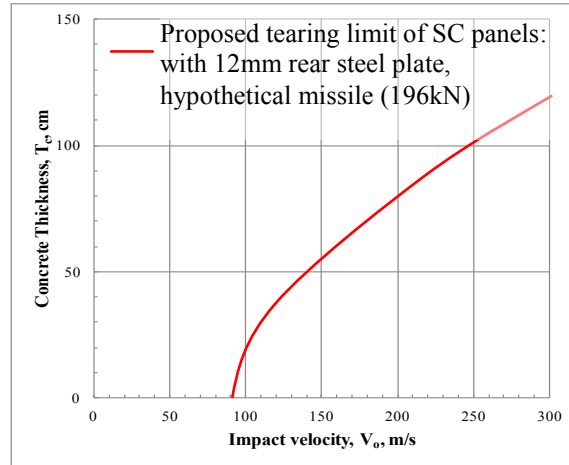

Figure 3 Proposed Tearing Limit of SC Panels against an Aircraft Impact [Mizuno et al (2005)]

A limitation of this figure is that it was developed for 12mm rear steel plates only and for one particular missile. Mizuno et al developed an idealized aircraft model based on an F-16 in order to compare their results with those of Sugano et al. This aircraft model had a weight of 196 kN (44,000 lbs) distributed through a deformable fuselage and wings and a rigid engine.

Figure 3 is useful but not general enough to be of broad use in design or evaluation of existing structures. A more comprehensive method is necessary for engineers to design walls for a wide range of internal and external, natural and man-made threats.

### THREE-STEP SC WALL IMPACT DESIGN PROCESS: PREVENT PERFORATION

The process described below enables design of an individual wall for a specific missile. This procedure requires the engineer to:

1. Select a concrete wall thickness,  $T_c$ , based on other design requirements (such as thickness required for other loadings, radiation shielding, etc.), or using 70% of that calculated by the modified NDRC equation,
2. Compute the residual velocity,  $V_r$ , of a missile after perforation (of the concrete) considering reduction factors for engine deformability, and
3. Calculate the required rear steel plate thickness,  $T_p$ , to prevent perforation.

NOTE: All equations in this paper are in imperial units (pounds, inches, and seconds)

These procedures only consider local failure due to missile impact. Global response such as deformation or flexural capacity may govern the design. No consideration of global response is made in the procedures in this paper.

#### **STEP 1: Select Concrete Wall Thickness, $T_c$**

There are three common design scenarios:

1. *Existing Design*: If preceding design steps have been completed and a preliminary wall design exists, the procedure in this report is a check of the existing design against missile impact.
2. *Wall Thickness Restriction*: If a design restriction such as a specified wall thickness exists then the engineer selects that specified thickness as the concrete thickness and uses this procedure to determine the minimum steel plate thickness required for a given missile impact.
3. *New Design*: For a new design that does not have design restrictions on wall thickness, we recommend that the engineer select the concrete wall thickness by using 70% of that required for an RC wall as determined by use of DOE-STD-3014 or NEI 07-13. Seventy percent of the required

thickness is recommended because previous studies have shown that the same impact resistance is achieved by an SC wall 30% thinner than an RC wall. (Mizuno, et al., 2005)

**STEP 2: Estimate the Residual Velocity,  $V_r$ , of a Missile Passing Through Concrete**

Figure 4 depicts the process of an engine missile moving through an SC panel and defines the changing velocities as it does. This procedure neglects the effect of the surface steel plate which is slightly conservative but tests show the surface steel plate has little effect on impact resistance. The plate does, of course, have tremendous impact on the structural behavior of SC walls under other loads.

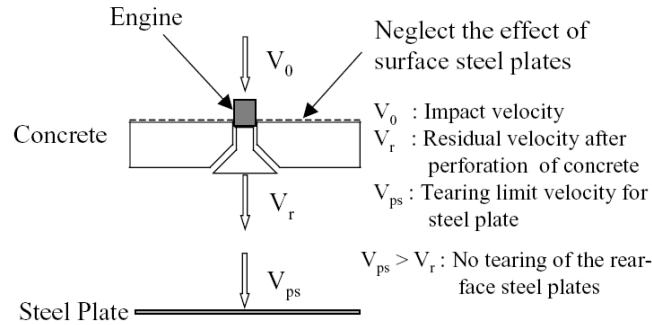

Figure 4 Evaluation Procedure for Tearing of SC Panels against Impact (from Mizuno et al (2005))

As the projectile impacts the concrete it dislodges a conical plug of concrete (with dimensions defined in Figure 5) which impacts the rear steel plate. Thus, the parameters for the projectile impacting the wall differ from the parameters for the projectile impacting the steel plate.

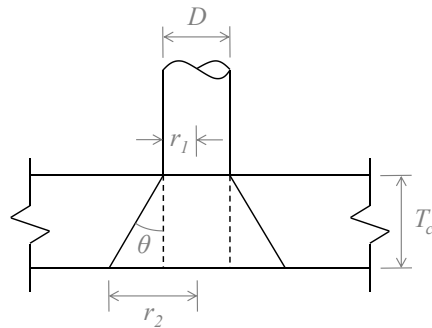

Figure 5 Conical Plug Geometry [after Kar (1979)]

Because the effect of the surface steel plate is neglected, the initial impact is modeled as an impact on concrete and the equations in NEI 07-13 are appropriate for this step. Estimate the residual velocity,  $V_r$ , using Equation (1) which is the same formula provided in NEI 07-13 [attributed to Sugano et al., (1993) and Kar, (1979)]. It is valid for rigid non-deformable missiles where the initial velocity,  $V_0$ , is less than the perforation velocity,  $V_p$ . In this equation,  $W_{CP}$  is the weight of the concrete plug [calculated from Equation (2)] and  $W$  is the weight of the missile.

$$V_r = \sqrt{\left\{ \frac{1}{1 + W_{CP}/W} \right\} (V_0^2 - V_p^2)} \quad (1)$$

$$W_{CP} = \frac{1}{3} \pi \rho_c T_c (r_1^2 + r_1 r_2 + r_2^2) \quad (2)$$

In Equation (2),  $\rho_c$  is the concrete weight density,  $T_c$  is concrete wall thickness,  $r_1$  is the minor radius and  $r_2$  is major radius calculated from Equation (3).

$$r_2 = r_1 + T_c \tan \theta \quad (3)$$

$$\theta = \frac{45^\circ}{\left(T_c / D\right)^{1/3}} \quad (4)$$

The perforation velocity is computed using the procedure described in NEI 07-13 Section 2.1.2.4. Rather than doing this in multiple steps, the equations are combined into a single equation to solve directly for  $V_p$ . The results are Equations (5) - (7) because the equations for penetration depth,  $x_c$ , and perforation thickness,  $t_p$ , differ depending on the ratio of penetration depth to missile diameter.

$$V_p = 1000 \cdot d \left( \frac{1}{1.44K \cdot W \cdot N \cdot d} \left( 2.2 \pm \sqrt{4.84 - 1.2 \left( \frac{T_c}{\alpha_p d} \right)^2} \right)^2 \right)^{0.556} \quad \text{for } \frac{T_c}{\alpha_p d} \leq 2.65 \quad (5)$$

$$V_p = 1000 \cdot d \left( \frac{1}{4K \cdot W \cdot N} \left( \frac{T_c}{1.29\alpha_p d} - 0.54 \right)^2 \right)^{0.556} \quad \text{for } 2.65 < \frac{T_c}{\alpha_p d} < 3.27 \quad (6)$$

$$V_p = 1000 \cdot d \left[ \frac{1}{K \cdot W \cdot N} \left( \frac{T_c}{1.29\alpha_p} - 1.54d \right) \right]^{0.556} \quad \text{for } \frac{T_c}{\alpha_p d} \geq 3.27 \quad (7)$$

The equivalent diameter,  $d$ , of the missile is “the diameter of a projectile that has the same contact surface areas as that of the actual missile” (Kar, 1979). It can be calculated from the projectile contact area,  $A_c$ , using Equation (8) (ASCE, 1980). In the above equations,  $K$  is computed by Equation (9),  $\alpha_p$  is a perforation reduction factor (0.6 for deformable missiles), and  $N$  is the missile shape factor [0.72 for flat-nosed, 0.84 for blunt-nosed, 1.0 for bullet-nosed, and 1.14 for sharp-nosed missiles, or computed by Equation (10) for hollow missiles such as pipe (Kar, 1979)].

$$d = \sqrt{\frac{4A_c}{\pi}} \quad (8)$$

$$K = \frac{180}{\sqrt{f_c}} \quad (9)$$

$$N_1 = 0.72 + \left( \left( \frac{D}{d} \right)^2 - 1 \right) 0.0306 \leq 1.0 \quad (10)$$

**STEP 3: Determine Required Rear Steel Plate Thickness,  $T_p$ , to Resist Perforation**

This step uses the formula presented by Børvik, et. al., (2009), rearranged into Equation (11) to solve for the required steel plate thickness,  $T_p$ , to prevent perforation. Their formula was developed for ductile metals and is modified here to include the weight of the concrete plug and the missile shape factor of 0.72 (flat-nosed) to account for the flat-nose of the concrete plug impacting the rear steel plate resulting in Equation (11). In this equation,  $m$  is the mass of the missile and concrete plug together,  $a$  is the equivalent radius of the missile, and  $\sigma_s$  is the quasi-static true radial compressive stress computed from Equation (12) which is presented by Børvik, et. al., (2009) based on a series of studies by Forrestal et al (1991, 1990, 1995).

$$T_p = 0.72 \left( \frac{(12V_r)^2 m}{2\pi a^2 \sigma_s} \right) \quad (11)$$

$$\sigma_s = \frac{f_y}{\sqrt{3}} \left( 1 + \left( \frac{E}{\sqrt{3}f_y} \right)^n \int_0^b \frac{(-\ln(x))^n}{1-x} dx \right) \quad (12)$$

In Equation (12),  $f_y$  is the yield strength,  $E$  is the modulus of elasticity, and  $n$  is the strain hardening exponent of the steel plate while  $b$  is an integration limit computed using Equation (13).

$$b = 1 - \frac{\sqrt{3}f_y}{E} \quad (13)$$

For common ranges of steel material properties, the expression for  $\sigma_s$  can be simplified to a linear equation based only on  $f_y$ . Equation (14) was developed using a modulus of elasticity of 29,000 ksi and strain hardening exponent of 0.20.

$$\sigma_s = 5.1f_y + 101000 \quad (14)$$

**COMPARISON TO EXPERIMENTAL RESULTS**

To confirm that this method provides reasonable results, data were gathered from 53 available tests of missile impact on SC walls (Walter & Wolde-Tinsae, 1984; Sugano et al., 1993; Hashimoto et al., 2005; and Mizuno et al., 2005.) Required rear steel plate thickness based on our calculations was compared to test specimen data. Of the 53 tests, 37 stopped the missile without perforating the rear steel plate and the remaining 16 had partial or full perforation of the steel plate.

The tests used for this comparison had a wide range of slab and missile parameters:

- Missile weight from 1.1 to 4630 lb
- Missile initial velocity from 377 to 886 ft/s
- Missile diameter from 1.75 to 39 in
- Concrete wall thickness from 2.4 to 54 in
- Concrete strength from 3000 to 6000 psi
- Steel plate thickness from 0.02 to 0.38 in
- Steel plate strength from 44 to 79 ksi

The experimental results demonstrate that the method described in this report provides reasonable and conservative results. For 14 of the 37 tests (38%) which stopped the missile the specimen had a thicker steel plate than we calculated was necessary to stop the missile for that specific test – we would

expect that these specimens would stop the projectiles. For the remaining 23 tests (62%) in which the projectile was stopped, the actual plate thickness was less than what we calculated to be necessary – a conservative result.

For 13 of the 16 tests (81%) in which the missile perforated the panel, the specimen had a thinner steel plate than was calculated to be necessary by Eq. 11—the specimen was expected to be perforated. For the remaining three tests (19%) in which the projectile perforated the slab, the actual plate thickness was larger than calculated by Eq. 11. All three of these cases were from Hashimoto et al’s (2005) tests and calculations for concrete thickness to preclude perforation indicated that the concrete alone would prevent perforation. In two of the cases, the thin rear steel plate was split. In the other, the thin rear plate was completely perforated. No residual velocity data was provided for these tests so it is not possible to say how close to the limit state these tests were but the results suggest that these tests were conducted near the perforation velocity. Because they failed to stop the missiles, however, these are certainly unconservative results.

### EXPANDED EMPIRICAL METHOD

Recognizing the limitation of Mizuno’s single graph but the potential value to designers, his approach was extended to develop similar graphs that apply to a wide variety of wall and missile combinations.

Figure 6 is for the minimum practical SC wall - an interior wall of 12” of concrete with 1/4” steel plates on front and back (4.2% reinforcement ratio). The three lines represent various missile diameters and the graph was developed for commonly used wall material properties ( $f'_c = 5000$  psi;  $\rho_c = 144$  lb/ft<sup>3</sup>;  $f_u = 50$  ksi). The graph is truncated at 50,000 lb for missile weight and 1500 ft/sec for initial velocity as these are the maximum practical values of internal or external missiles (aircraft, turbine, or tornado). If the specified missile to design against (diameter, weight and initial velocity) falls below the applicable line in Figure 6 then the wall will prevent perforation. Figure 6 is valid only for non-deformable, flat-nosed missiles. Equivalent graphs can be generated for various nose types and for deformable missiles.

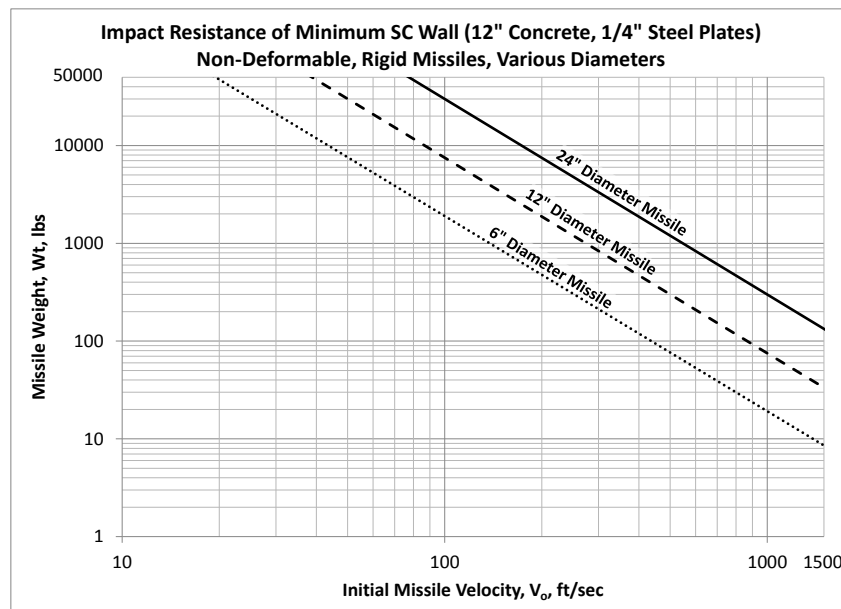

Figure 6 Non-deformable (Rigid) Missile Resistance of Minimum SC Wall ( $T_c=12''$ ;  $T_p=0.25''$ )

While Figure 6 is useful for determining the capacity of the minimum practical wall, it is still limited: it only applies to one wall configuration. Figure 7 and Figure 8 were generated for a flat-nosed, 6” diameter rigid missile impacting walls of any thickness. The horizontal and vertical scales are kept the same for both graphs in order to more easily compare the influence of reinforcement ratio (total steel plate

thickness to concrete thickness). For an SC wall with 5% reinforcement, Figure 7 provides the required concrete wall thickness for an initial missile velocity for a variety of missile weights. Figure 8 provides the same for 1.5% reinforcement. These graphs are more broadly applicable than any of the preceding graphs. Comparing these two graphs gives an indication of the influence of reinforcement ratio. These graphs only depict the capacity to resist local damage and do not account for global response to the missile impact.

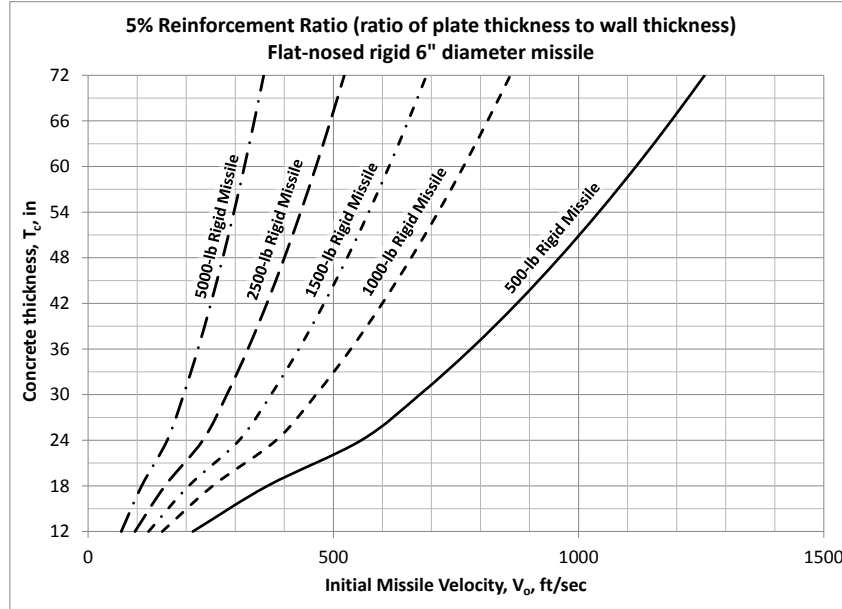

Figure 7 Required SC Wall Thickness to Prevent Perforation (6" Diameter, Flat-Nose, Rigid Missile, 5% Reinforcement)

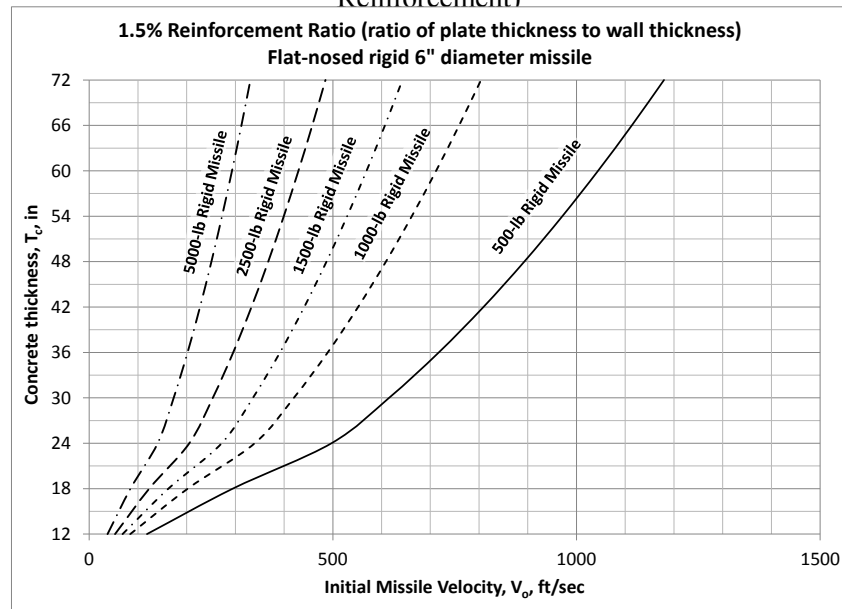

Figure 8 Required SC Wall Thickness to Prevent Perforation (6" Diameter, Flat-Nose, Rigid Missile, 1.5% Reinforcement)

To appreciate the benefit of SC walls over RC walls, Figure 9 compares the impact resistance of an RC wall to SC walls of 1.5% and 5% reinforcement for a 1000-lb missile. The required RC wall thickness is calculated to resist scabbing – the governing limit state for RC.



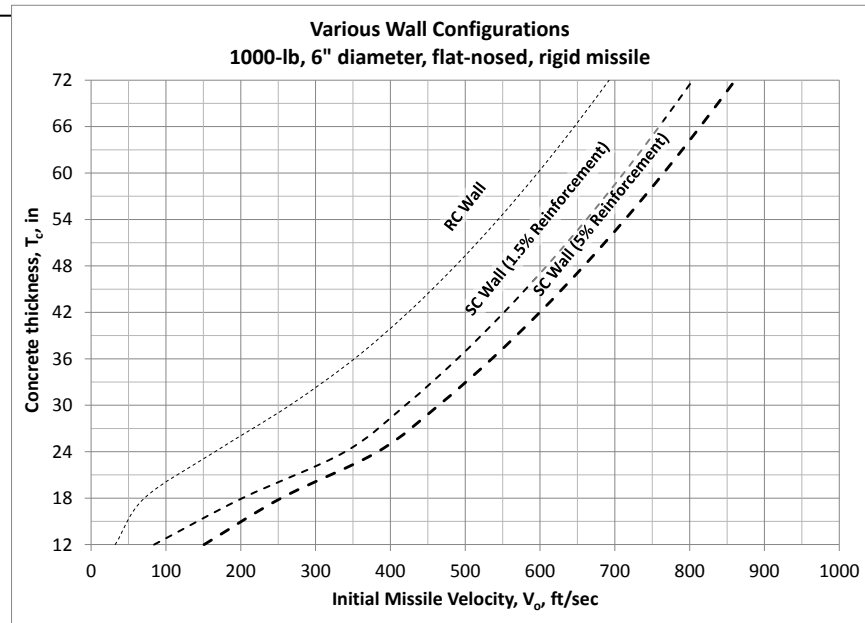

Figure 9 Required Wall Thickness for 1000-lb Missile (Rigid Missile)

### RESISTANCE TO DESIGN-BASIS TORNADO AND HURRICANE MISSILES

The minimum 12” concrete, ¼” steel plate SC wall resists perforation by schedule 40 pipe design basis tornado and hurricane missiles as defined by Regulatory Guidelines (RG) 1.76 and 1.221. (NRC, 2007 and 2011) This information is summarized in Table 1. The worst case hurricane wind speed is for the 150 m/s (336 mph) hurricane winds in Table 2 of RG 1.221

Table 1 SC Wall Resistance to Perforation by Design Basis Tornado and Hurricane Missiles

Schedule 40 Pipe (Design Basis Missile)	Weight (lb)	Velocity (ft/sec)	Diameter (in)	Minimum SC Wall Prevents Perforation?
Tornado (Region 1)	287	135	6.6	Yes
Hurricane (Worst Case)	287	308	6.6	Yes

### CONCLUSIONS

There currently is no approved method available to design SC walls to resist perforation from missile impacts. There is a large body of research to design RC walls for impact loading and some work within the last two decades to expand this to SC walls. The majority of research of impact design of SC walls has been completed in Japan by Mizuno et al, Sugano, and Morikawa. This paper summarizes a straightforward design method to compute the required steel plate thickness on an SC wall to prevent perforation from missile impact. The method described in this paper provides SC wall designs that compare well to a large body of experimental test data for a wide variety of missile and slab parameters.

---

## REFERENCES

- ACI Committee 349. (2007). *Code Requirements for Nuclear Safety-Related Concrete Structures (ACI 349-06) and Commentary* (p. 157). Farmington Hills, MI: American Concrete Institute.
- American Society of Civil Engineers. (1980). *Structural Analysis and Design of Nuclear Plant Facilities (ASCE - Manuals and Reports on Engineering Practice - No. 58)*. (p. 553). New York, NY: American Society of Civil Engineers.
- Børvik, T., Forrestal, M. J., Hopperstad, O. S., Warren, T. L., & Langseth, M. (2009). "Perforation of AA5083-H116 aluminium plates with conical-nose steel projectiles – Calculations." *International Journal of Impact Engineering*, 36(3), 426–437.
- Degen, P. P. (1980). "Perforation of RC panels by rigid missiles." *Journal of Structural Engineering*, 106(7), 1623–1642.
- Forrestal, M., Brar, N., & Luk, V. (1991). "Penetration of strain-hardening targets with rigid spherical-nose rods." *Journal of applied mechanics*, 58(March), 7–10.
- Forrestal, M. J., Luk, V. K., & Brar, N. S. (1990). "Perforation of aluminum armor plates with conical-nose projectiles." *Mechanics of Materials*, 10(1-2), 97–105.
- Forrestal, M., & Tzou, D. (1995). "Penetration into ductile metal targets with rigid spherical-nose rods." *International Journal of Impact Engineering*, 16(5/6), 699–710.
- Hashimoto, J., Takiguchi, K., Nishimura, K., Matsuzawa, K., Tsutsui, M., Ohashi, Y., Kojima, I., et al. (2005). "Experimental Study on Behavior of RC Panels Covered with Steel Plates Subjected to Missile Impact." *18th International Conference on Structure Mechanics in Reactor Technology (SMiRT 18)* (pp. 2604–2615). Beijing, China.
- Kar, A. (1979). "Residual velocity for projectiles." *Nuclear Engineering and Design*, 53, 87–95.
- Mizuno, J., Sawamoto, Y., Yamashita, T., Engineering, N. P., Koshika, N., Niwa, N., & Suzuki, A. (2005). "Investigation on Impact Resistance of Steel Plate Reinforced Concrete Barriers Against Aircraft Impact Part 1 : Test Program And Results." *18th International Conference on Structure Mechanics in Reactor Technology (SMiRT 18)* (pp. 2566–2579). Beijing, China.
- Mizuno, J., Tanaka, E., Nishimura, I., Koshika, N., Suzuki, A., & Mihara, Y. (2005). "Investigation on Impact Resistance of Steel Plate Reinforced Concrete Barriers Against Aircraft Impact Part 3 : Analyses of Full-Scale Aircraft Impact." *18th International Conference on Structure Mechanics in Reactor Technology (SMiRT 18)* (pp. 2591–2603). Beijing, China.
- Sugano, T., Tsubota, H., & Kasai, Y. (1993). "Local damage to reinforced concrete structures caused by impact of aircraft engine missiles Part 1. Test program, method and results." *Nuclear Engineering and Design*, 140, 387–405.
- Sugano, T., Tsubota, H., Kasai, Y., Koshika, N., Itoh, C., Shirai, K., Von Reisemann, W. A., et al. (1993). "Local damage to reinforced concrete structures caused by impact of aircraft engine missiles Part 2. Evaluation of test results." *Nuclear Engineering and Design*, 140, 407–423.
- U.S. Department of Energy. (2006). *ACCIDENT ANALYSIS FOR AIRCRAFT CRASH INTO HAZARDOUS FACILITIES (DOE-STD-3014-2006)* (October 19., p. 215). Washington, D.C.: U.S. Department of Energy.
- U.S. Nuclear Regulatory Commission. (2007). Regulatory Guide 1.76, Revision 1, "Design-Basis Tornado and Tornado Missiles for Nuclear Power Plants". Washington, D.C.: U.S. Nuclear Regulatory Commission.
- U.S. Nuclear Regulatory Commission. (2011). Regulatory Guide 1.221, "Design-Basis Hurricane and Hurricane Missiles for Nuclear Power Plants". Washington, D.C.: U.S. Nuclear Regulatory Commission.
- Walter, T. A., & Wolde-Tinsae, A. M. (1984). "Turbine missile perforation of reinforced concrete." *Journal of Structural Engineering*, 110(10), 2439–2455.