



Verification of dynamic characteristics and response results of the VVER-440/213 main building complex Paks based on latest blast experiments

Katona T.⁽¹⁾, Ratkai S.⁽¹⁾, Halbritter A.⁽²⁾, Krutzik N.J.⁽²⁾, Schütz W.⁽²⁾

(1) Nuclear Power Plant Paks Ltd, Hungary

(2) Siemens AG, Germany

ABSTRACT

Blind preanalyses were prepared for the main building complex of the VVER-440/213 PAKS on the basis of updated soil data as well as on excitation data determined by means of measurements during explosion tests performed within the framework of the Research Programme on "Benchmark Studies for Seismic Analysis and Testing of VVER-Type Nuclear Power Plants" supported by the IAEA, Vienna.

The aim of this investigation was to validate modeling concepts for idealization of the dynamic capabilities of the structures and the soil, by comparing dynamic characteristics (eigenfrequencies, eigenmodes, modal values) and to validate the structural response results (time histories and response spectra) obtained by test and the analysis.

In order to evaluate the new results using the analysis and test results derived for the same VVER-440/213 building complex during earlier (1990/91) explosive tests at the PAKS site, a number of characteristic data were compared.

INTRODUCTION

A number of distant explosion tests in the vicinity of the site PAKS had been performed by Nuclear Power Plant LTD during the years 1990/91. In order to verify the dynamic characteristics of the VVER-440/213 building structures. Analytical precalculations were performed and a comparison of test and analysis results was prepared at the same time. The results showed the adequacy of the modeling of the structures and the soil-structure interaction effects [1], [2]. Due to the fact however that some measured results were not available (failures of some recording gages) it was not possible to build up a total picture of the dynamic behavior of the structures. There were also doubts with regard to the appropriateness of the soil data because the measured eigenfrequencies were slightly higher than the calculated eigenfrequencies.

Due to these facts, the decision was taken to repeat the distant explosion tests with the help of the IAEA (Vienna) and the support of some western companies (ISMES, Bergamo). In parallel soil investigations were performed in order to update the existing soil data.

The results of this investigation are documented in [3] and [4]. In addition to the updated input data, the mathematical models were verified and refined on the basis of as-built information obtained during a number of walkdowns which had been performed in the meantime.

The aim of this investigation was to repeat analytical calculations (as a blind precalculation) and reevaluate the comparison of analytical and experimental results (received after the calculations had seen finished and submitted).

In the first step, the results of the latest measured and calculated results will be evaluated by means of a comparison of dynamic characteristics and response spectra. In a second step the results of the later and recent analytical and experimental tests will be compared and evaluated.

COUPLED VIBRATING SYSTEM

The description of the complex system of coupled vibrating structures of the VVER-440/213 is given in detail in several publications related to this subject [1] and [5] to [8].

In order to investigate the dynamic behavior of the main building complex (Figure 1) in greater detail, a coupled three-dimensional model including the reactor building, the condensing tower, the lateral galleries and the turbine hall was generated (Figure 10). This ensured, the real interaction between buildings. The latest finite element model [9] of the PAKS main building/turbine hall generated on the basis of these aspects has approximately 28000 dynamic degrees-of-freedom. It comprises 4700 nodal points, 5400 plate elements (square and triangular elements) and 4600 beam elements.

The weight of the model is composed by the proper weight of the structure, by the weight of the important components and the weight from electrical and mechanical components and non-dead weights. Due to the construction method precast walls and plates do not exhibit stiffness. For this reason they were modeled on the basis of zero stiffness and real specific weight.

The total weight of the structure processed automatically on the basis of the input geometry and properties of the model is approximately 2 800 000 kN. Small weights and non-permanent weights were considered, thus increasing the specific weight of the corresponding floors. The dynamic structural interaction between two units had been studied as part of an earlier investigation [2] which concluded that it can be neglected. Interaction between the building structure and the soil was taken into account by means of a complex (coupled) mathematical model for the soil and the structure. This ensured that not only the elastic deformability of the foundation as well as the soil to absorb translational, rocking and torsional motion but also their radiation hysteretic damping would be properly accounted for. The soil layering and the soil dynamic data (Figure 2 and Table 1) were used in accordance with Ref. [4]. The mathematical representation of the layered soil was based on the shear moduli and damping derived for the upper bound of the soil data (G_{max}) which are close to the shear modulus for smallest strains (Figures 3 and 4).

Impedance functions (required for calculation of the dynamic characteristics) for the different soil conditions G_{max} were calculated on the basis of the soil layering and the soil properties as well as a rigid representation of the foundations.

The global frequency-independent soil stiffnesses and damping (Table 2) underneath the reactor building were derived from the impedance function for the corresponding G-value (G_{max}) by matching these with the fundamental frequencies of the coupled soil-structures system. The stiffnesses for the galleries and turbine house foundations were determined in the same way. The discrete springs for translational motion were defined in accordance with the individual surface of the foundation slab. The stiffnesses were lumped at individual nodes of the foundation slab based on the assumption of uniform distribution of bearing pressure. Finally, the equivalent soil springs and dampers were placed at all nodal points of the discretized foundation slab.

DISTANT EXPLOSION EXCITATION

During the first series of the investigations at the PAKS site (1990/91) a number of explosion tests were performed using charges from 20 kg to 500 kg TNP located at a distance of 2.5-4.5 km (Figure 5). 50 kg of explosive material was located in each 20-m-deep borehole. The distances of the explosion points and masses of the charges were determined by a number of preliminary tests. During the recent (1995) explosion tests much smaller charges were used and the boreholes were located much closer (120 m) to the building main complex of Unit 1.

The measured excitation waves used in the two blind preanalyses are shown in Figures 6 to 9. They have a total duration of 30 s and 20 s and maximum values of acceleration amplitudes of about 0.06 or 0.02 m/s² for the horizontal and about 0.18 or 0.02 m/s² for the vertical direction respectively. The vertical and horizontal excitations were considered as acting simultaneously.

DYNAMIC CHARACTERISTICS

The main dynamic characteristics such as eigenfrequencies, mode shapes, modal dampings and modal masses were computed for the soil condition G_{max} . It was found that the sum of the modal weights for each direction up to about 6 Hz almost equals the total weights ($\geq 92.0\%$) of the structure. However, within the band width of the frequency range relevant to the explosive loading condition (around 15 Hz) there are no significant global or local modes existing in the eigenvalue solution. For G_{max} the fundamental frequencies of the main building concrete block in the horizontal directions were about 1.65 to 4.30 Hz and in the vertical direction 2.07 to 4.07 Hz (Table 3). The frequencies of the turbine house and of the reactor hall start at about 0.92 Hz.

Slightly different assumptions than those made for an earthquake were used with regard to the limitation of modal damping. Based on the damping values gained during earlier pre- and post-analyses for explosion tests, damping values of 8 % and 10 % were used for the horizontal and for the vertical vibration modes of the building (Table 4).

STRUCTURAL RESPONSE

The dynamic response of the main building complex was calculated using the frequency domain approach. The response spectra were calculated for the foundation mat (A), the 18.9 m floor (B) as well as the supporting regions (C) of the crane (Figures 1). Based on the secondary time histories obtained for these locations, response spectra for 2 % damping were derived (Figures 11 to 13). In Figures 14 and 15 the comparison of calculated and measured spectra derived for the same locations during earlier (1990/91) explosive tests are shown.

CONCLUSIONS

Analysis of the characteristics obtained by analysis and test allows the following conclusions to be drawn:

- The new soil capabilities derived for the PAKS site appear to be more appropriate and the dynamic characteristics obtained for G_{max} (which are very close to G_0 , Figure 4) show good agreement to the results of the experiments).
- The damping ratios obtained by experiment during the first phase (1990/91) of tests were considered to be adequate for explosion loadings. For earthquake loadings however

higher (proportional to the strain level) damping should be used following adaptation to real earthquake strains.

- The comparison of response spectra obtained by measurements and calculation is more or less satisfactory in both cases. Due to the fact however that the excitations induced during the first series of the tests (1990/91) were closer to the fundamental frequency range of PAKS structures (1.6-2.1 Hz) they were more appropriate for the validation of the accuracy of the mathematical models. By means of the excitations induced by the latest tests the quality of the models for loadings with frequency ranges above 15 Hz could be verified.
- The experimental investigation validated the results of the analytical calculations prepared for the PAKS Nuclear Power Plant VVER-440/213.

REFERENCES

- [1] T. Katona, L. Turi, A. Halbritter, N.J. Krutzik
Experimental and Analytical Investigation of PAKS NPP Buildings Structures
10 WCEE Madrid, July 1992
- [2] T. Katona, N.J. Krutzik
Verification of Dynamic Response Characteristics by Natural Scale Experiments
IAEA-Research Coordination Meeting, PAKS September 1993
- [3] IAEA Letter dated October 5th, 1995
Accompanying disk containing files with relevant acceleration recorded during the explosive tests on the PAKS site at location FF
- [4] Site Investigation of Site Response and Liquefaction Potential
Ove Arup & Partners International, London
Interpretative Report, dated October 1995
- [5] A. Halbritter, T. Katona, N.J. Krutzik, L. Turi,
Dynamic Response of VVER-440/213 PAKS Nuclear Power Plant to Seismic Loading Conditions and Verification of Results by Natural Scale Experiments
Post SMiRT-12th CONFERENCE, Vienna, 1993
- [6] N.J. Krutzik, A. Halbritter
Comparative Evaluation of the Results of Seismic Analysis of the VVER-440/213 Reactor Building for Soft Soil Conditions (PAKS) Performed During Benchmark Studies 93/94 and Derivation of Design Response Spectra for Analysis and Testing of Components and Systems
IAEA-Research Coordination Meeting, CKTI, St. Petersburg, June 19-23, 1995
- [7] M. David, A. Halbritter, N.J. Krutzik
In-Structure Response Data of the VVER 440/213 NPP for the Analysis and Qualification of M & E Components
SMiRT 13th Conference, Porto Alegre, August 1995
- [8] N.J. Krutzik, D. Papandreou
Blind Preanalysis of the Main Building Complex of the VVER-440/213 PAKS NPP for Comparison of Analytical and Experimental Results Obtained by Last Explosive Tests
IAEA - Research Coordination Meeting ISMES, Bergamo, June 3-7, 1996
- [9] A. Halbritter
Mathematical Model of the Main Building Complex VVER 440/213 Paks
Technical Report Siemens KWU NDA2/96/E0530

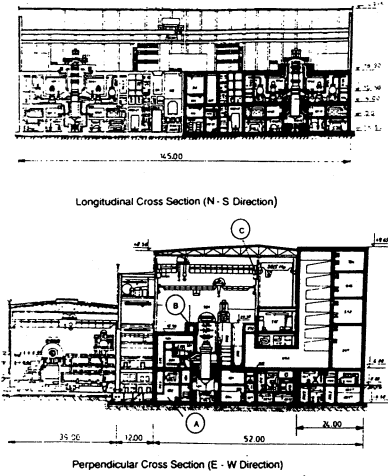

Fig. 1 Constructional Concept of a VVER-440/213

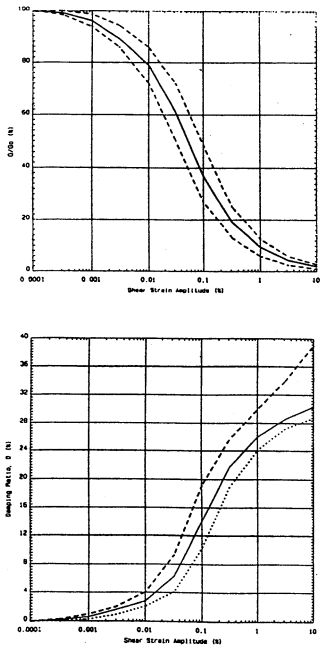

Fig. 3 Variation of Shear Modulus and Damping Ratio with Strain

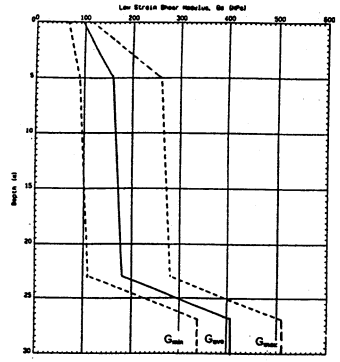

Fig. 2 Shear Modulus of Design Soil Profile (Low Strain Values and Best Estimate)

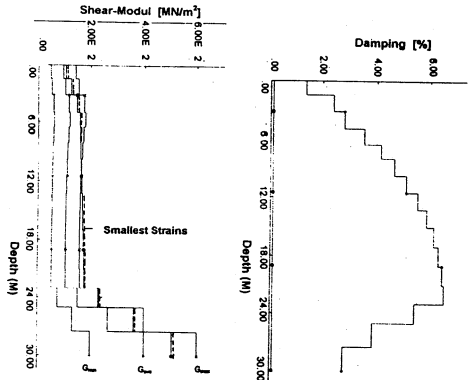

Fig. 4 Strain Compatible Shear Module and Damping

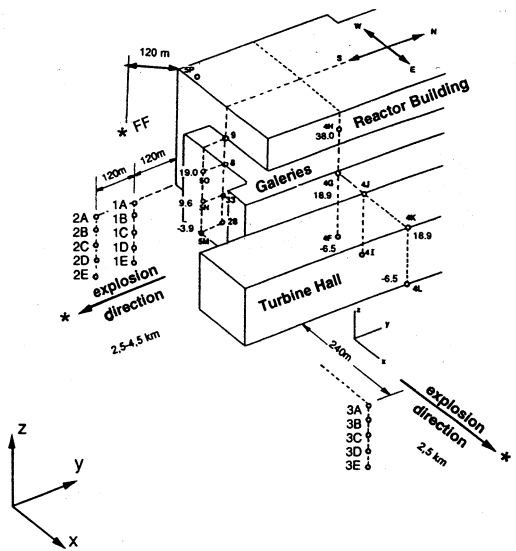

Fig. 5 PAKS Nuclear Power Station Site Arrangement of Measuring Points (2nd Series of Experiments)

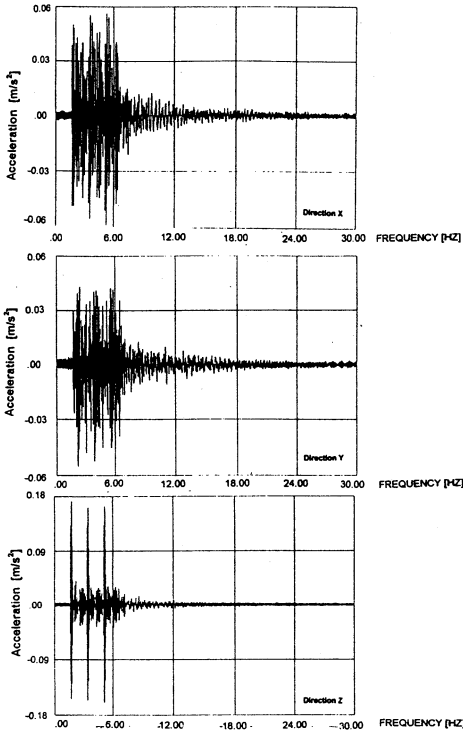

Fig. 6 Free-Field Acceleration Time Histories nearby the Reactor Building (Test III / FF 100 kg)

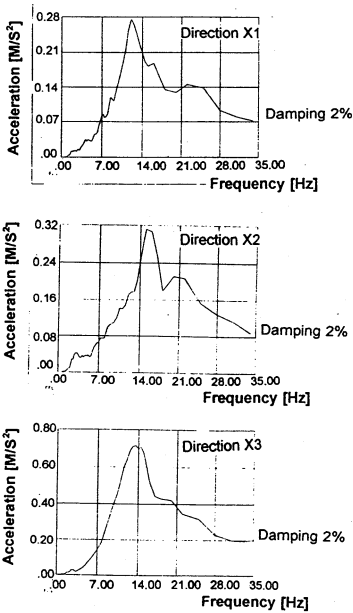

Fig. 7 Free Field Response Spectra (2% Damping) nearby the Reactor Building (Test III / FF 100 kg)

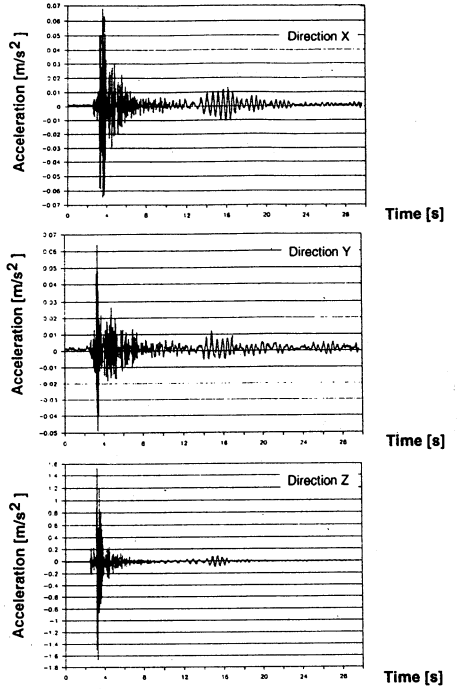

Fig. 8 Free Field Acceleration Time Histories at 240 m from the Building (Test I / S, 500 kg)

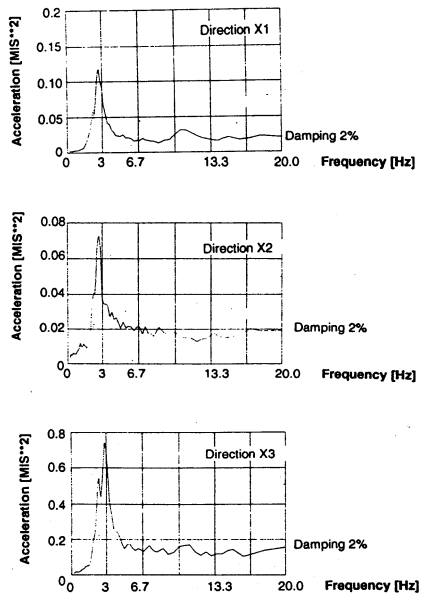

Fig. 9 Free Field Response Spectra at 240 m from Building (Test I / S, 500 kg)

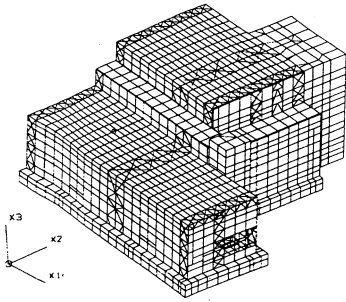

Fig. 10 Mathematical Model (3) of the main Building Complex Paks

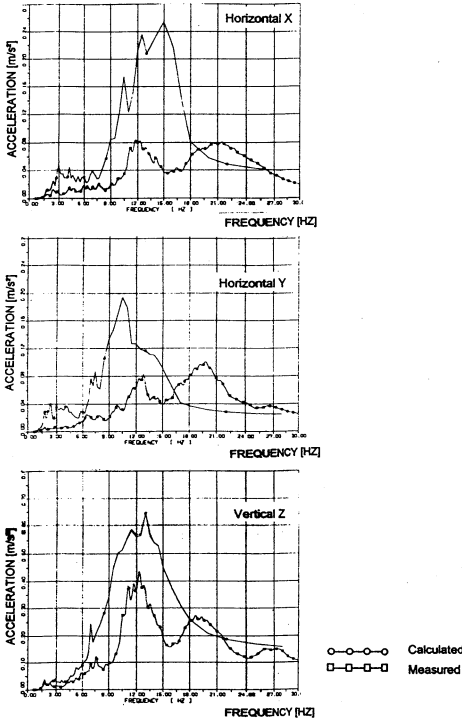

Fig. 11 Comparison of Floor Response Spectra (D = 2%) at Foundation Level (Test III / FF 100 kg)

Tab. 1 Soil data for Upper Soil Layers

| LAYER No | DEPTH (upper level m) | Density of Layer kg/m ³ | G _{max} Mpa | Shear wave velocity m/s | Poisson's ratio |
|----------|-----------------------|------------------------------------|----------------------|-------------------------|-----------------|
| 1 | 0 | 1000 | 95.0 | 223.6 | 0.30 |
| 2 | -1.50 | 1000 | 114.5 | 245.5 | 0.30 |
| 3 | -3.20 | 1000 | 136.6 | 268.1 | 0.30 |
| 4 | -5.00 | 1000 | 160.0 | 290.2 | 0.30 |
| 5 | -6.50 | 1000 | 181.5 | 311.5 | 0.30 |
| 6 | -8.00 | 2000 | 163.0 | 285.5 | 0.30 |
| 7 | -9.75 | 2000 | 165.0 | 287.2 | 0.48 |
| 8 | -11.50 | 2000 | 167.0 | 289.0 | 0.48 |
| 9 | -13.25 | 2000 | 169.0 | 290.7 | 0.48 |
| 10 | -15.00 | 2100 | 171.0 | 285.4 | 0.48 |
| 11 | -17.00 | 2100 | 173.3 | 287.3 | 0.48 |
| 12 | -19.00 | 2100 | 175.6 | 289.2 | 0.48 |
| 13 | -21.00 | 2100 | 177.8 | 291.0 | 0.48 |
| 14 | -23.00 | 2100 | 180.0 | 292.8 | 0.48 |
| 15 | -24.50 | 2100 | 266.0 | 355.9 | 0.48 |

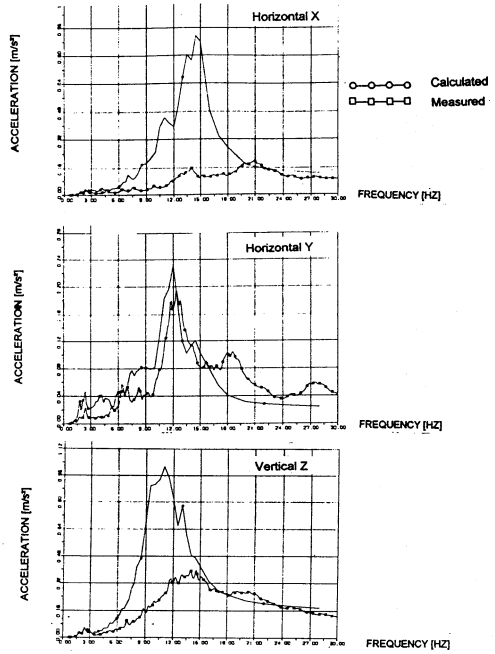

Fig. 12 Comparison of Floor Response Spectra (D = 2%) at the 18.9 m Elevation (Test III / FF 100 kg)

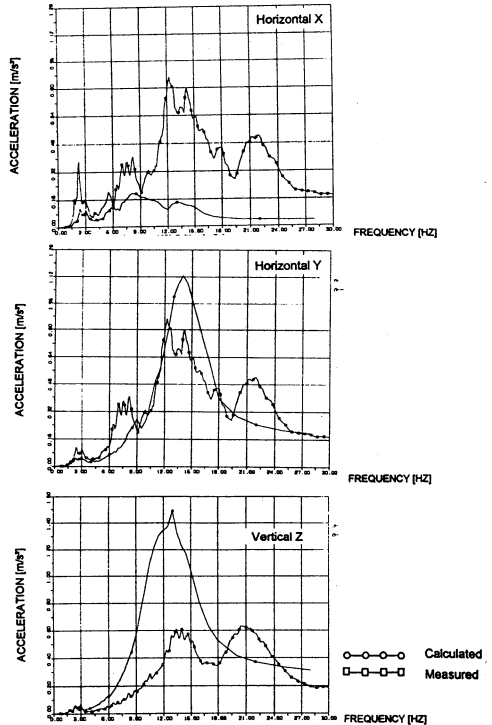

Fig. 13 Comparison of Floor Response Spectra (D = 2%) at the Elevation of Cran Tracks (Test III / 100 kg)

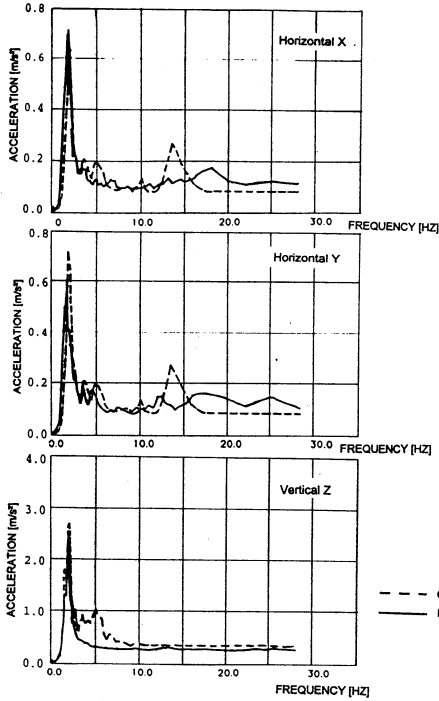

Fig. 14 Comparison of Response Spectra (D = 2%) at Foundation Level (Test I / S, 500 kg)

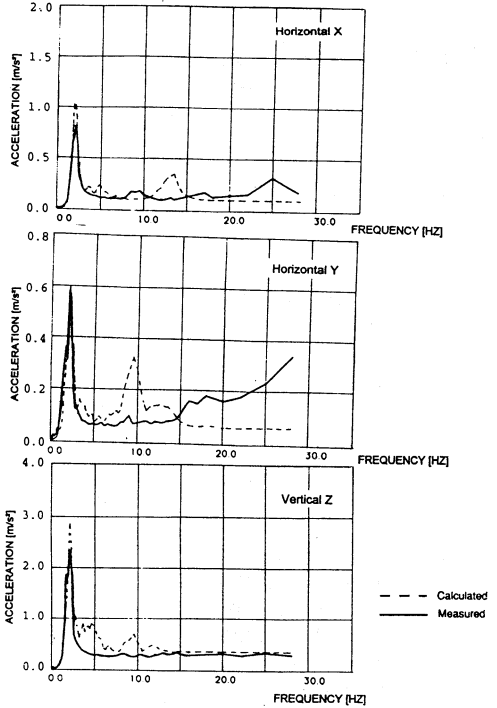

Fig. 15 Comparison of Floor Response Spectra (D = 2%) at the Elevation 18.9 m (Test I / S, 500 kg)

Tab. 2 Frequency Independent Stiffnesses and Dampings

| G MAX | | | | | | |
|-----------|------|------|-------|-------|-------|------|
| DIR | X | Y | Z | XX | YY | ZZ |
| Ko [kN,m] | 68E6 | 68E6 | 148E6 | 109E9 | 105E9 | 92E9 |
| K [kN,m] | 59E6 | 59E6 | 130E6 | 96E9 | 92E9 | 77E9 |
| D [%] | 8 | 8 | 10 | 8 | 8 | 8 |

Tab. 3 Comparison of Measured (1990/91) and Calculated Eigenfrequencies of the Reactor Building [2] with New Results (1997)

| Mode No. | Eigenfrequencies [Hz] | | | |
|----------|-----------------------|-----------|------------|-----------|
| | Measured | | Calculated | |
| | [2] | 1997 | [2] | 1997 |
| 1 | 1.6-2.1 | not | 1.84 | 1.65-1.90 |
| 2 | 1.9-2.1 | Published | 2.12 | 2.22-2.33 |
| 3 | 2.3 | fill | 2.38 | 2.33 |
| 4 | 2.5 | now | 2.82 | 3.77 |
| 5 | | | | 4.38 |
| 20 | 3.9-4.1 | | 4.16 | 2.07-4.07 |
| vertical | | | | |

Tab. 4 Damping [%] Values Obtained from Measured Results (1990/91)

| Structure | Region | Explosion East | | | Explosion South | | |
|------------------|--------|----------------|------|---|-----------------|------|-------|
| | | X | Y | Z | X | Y | Z |
| Reactor Building | 4G | 6.9 | | - | | 9.1 | 10.1 |
| | 4H | 7.5 | 6.8 | | | 8.7 | (5.5) |
| | 5P | 10.0 | 7.7 | | 11.8 | 10.4 | 6.4 |
| Turbine Hall | 4K | 6.4 | | | 9.8 | 9.4 | 8.1 |
| Galleries | 5O | 6.1 | 9.4 | | 8.4 | 9.2 | 14.8 |
| Average Value | | 7.38 | 7.97 | | 10.0 | 9.36 | 9.85 |

| Damping Values used in the Calculation | X | Y | Z |
|--|---|---|----|
| | 8 | 8 | 10 |