

# Study on Lead Extrusion Damper as a Seismic Support

**T. Nomura, N. Kojima,**  
*Mitsubishi Heavy Industries, Ltd., Kobe, Japan*

**I. Shimoda, C. Tsuruya**  
*Oiles Industry Co., Ltd., Fujisawa, Japan*

**K. Fujita, T. Ito**  
*Mitsubishi Heavy Industries, Ltd., Takasago, Japan*

**T. Nakatogawa, Y. Takayama**  
*Mitsubishi Atomic Power Industries, Inc., Tokyo, Japan*

## ABSTRACT

The fundamental characteristics of two types of Lead Extrusion Dampers (Cylinder type, Rotary type) for use as the nuclear power plant piping support of the elasto-plastic of damper were clarified.

As a result, these Lead Extrusion Dampers were found to have the following dynamic characteristics;

- (a) Hysteresis loop is both rectangular shape and bi-linear shape.
- (b) Maximum reaction force is independent of velocity and frequency but it increases as displacement exceeds the specified value.
- (c) The dissipated energy is very large and is independent of velocity, frequency and initial displacement (i.e. thermal expansion of pipings) in the range of test.

## INTRODUCTION

At the present, the seismic design of the nuclear power plant piping uses the mechanical snubber or hydraulic snubber as supports under the rigid design philosophy.

However, initial costs and running costs of such devices are high. Recently, to rationalize such supports several devices have been developed which can absorb the piping vibration energy, and are not expensive and have high reliability.

The Lead Extrusion Damper (L.E.D.) is one of them. It was originally developed as an energy absorbing device by Department Seismic and Industrial Research, Physics and Engineering Laboratory. In New Zealand, L.E.D. has been installed in some seismic isolated bridge.

This paper reports that L.E.D. is feasible as nuclear power plant piping supports based on the results of experiments.

### Mechanism and Structure of L.E.D.

L.E.D. can absorb vibration energy by plastic deformation of lead which has the characteristic of super plasticity. Any deformation of lead at or above room temperature is in fact "hot work" in which the processes of recovery, recrystallization and grain growth are occurring simultaneously. Furthermore, lead does not have metal fatigue property.

The cylinder type is shown in Fig. 1. It consists of a tube, a central shaft with a bulge and lead filling the space between them. The bulge is shown in detail in Fig. 2. The central shaft is supported by bearings which also serve to hold the lead in place. As the shaft moves relative to the tube, the lead must extrude through the orifice formed by the bulge and the tube.

The rotary type which was newly developed by the authors is shown in Fig. 3. It consists of a housing, a rotational shaft with bulges and lead filling the space between them. As the shaft rotates relative to the housing, the lead must extrude through the orifice formed by the bulge and tube. There is a key between the housing and the outside of the lead and it prevents the rotation of lead though the shaft revolves.

## Experiment

These devices were connected to the test facility with hydraulic servo cylinder through the pin. Test parameters were displacement amplitude and frequency. This test was performed to obtain the relation between reaction force and velocity, frequency and displacement amplitude.

## Test Results and Discussions

### Hysteresis Loop

The hysteresis loop of the cylinder type is shown in Fig. 4 and that of the rotary type is shown in Fig. 5.

In the case of the cylinder type, hysteresis loop is rectangular when the displacement is less than 10 mm and it becomes more round as the displacement becomes larger than 10 mm. When the displacement is small, this damper acts as a friction type damper.

On the other hand, in the case of the rotary type, the hysteresis loop is round and rectangular. This damper acts as an elasto-plastic damper.

Because the height of the bulge of the cylinder type is lower than that of the rotary type and the length of bulge summit is longer than that of the rotary type for the same capacity, the friction force is larger than reaction force by plastic flow of lead in the case of the cylinder type.

### Relationship between Reaction Force and Maximum Velocity

Reaction force and velocity of the cylinder type is shown in Fig. 6 and that of the rotary type is shown in Fig. 7. In both types, reaction force was found to be remarkably independent of velocity.

### Relationship between Reaction Force and Frequency

Relationship between force and frequency of a cylinder type is shown in Fig. 8 and that of the rotary type is shown in Fig. 9. Reaction force is independent of frequency in both types.

### Relationship between Reaction Force and Displacement

The relationship between force and displacement in the cylinder type is shown in Fig. 10 and that of the rotary type is shown in Fig. 11. In the case of the cylinder type, reaction force is twice as larger when the displacement is 20 mm as at other levels of displacement. The reaction force depends on the displacement when the displacement is larger because lead yields and orifice effect occurs.

In the case of the rotary type, reaction force increases with the increase of displacement. Displacement is obtained as (rotation angle of a rotational shaft) x (length of an arm ; 110 mm) and orifice effect occurs though the rotation of the shaft is slight.

## CONCLUSION

Fundamental tests to obtain the dynamic characteristics of two types of L.E.D. were performed which will be applied as seismic supports for the nuclear power plant pipings. From the results, the following facts are clarified.

- Hysteresis loop is both rectangular and bi-linear in shape.
- Reaction force is independent of velocity and frequency but increases as displacement becomes larger than the specified value.

These devices seem to be feasible as one of the new type of seismic supports. In the future, the following tests will be carried out in order to clarify some properties of L.E.D., and the quality of L.E.D. will continue to be improved.

- Very low velocity test like the thermal expansion movement of pipings
- Endurance test
- High temperature, high humidity test

**REFERENCE**

W.H. Robinson et al. "An Extrusion Energy Absorber Suitable for the Protection of Structures During an Earthquake" EARTHQUAKE ENGINEERING AND STRUCTURAL DYNAMICS Vol. 4, P.251 ~ 259 (1976).

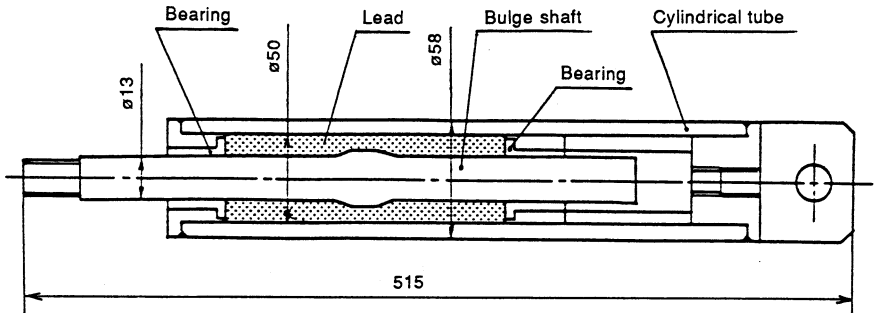

Fig. 1 L.E.D. (Cylinder type)

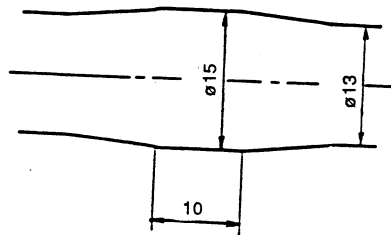

Fig. 2 Detail of Bulge Shaft

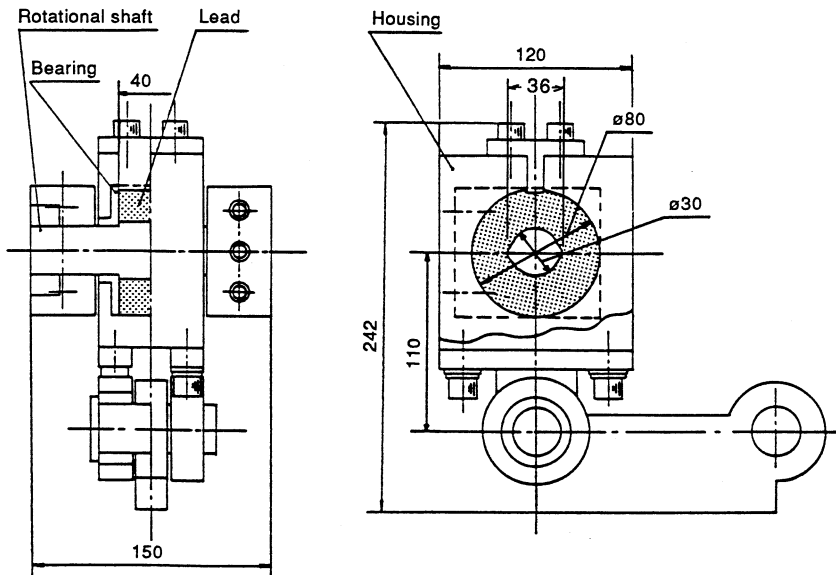

Fig. 3 L.E.D. (Rotary type)

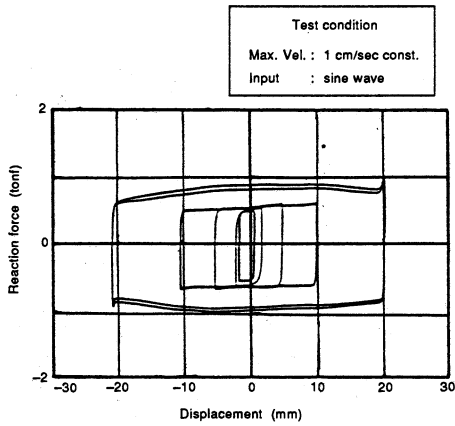

Fig. 4 Hysteresis Loop of the L.E.D. (Cylinder type)

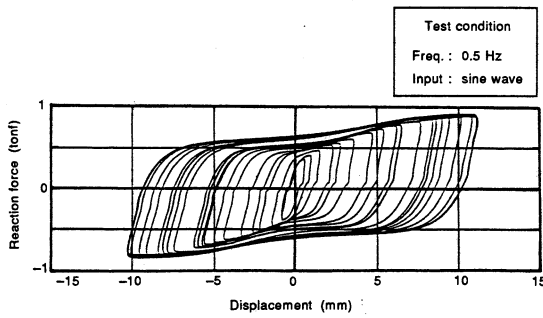

Fig. 5 Hysteresis Loop of the L.E.D. (Rotary type) (Gradually increasing and decreasing waves)

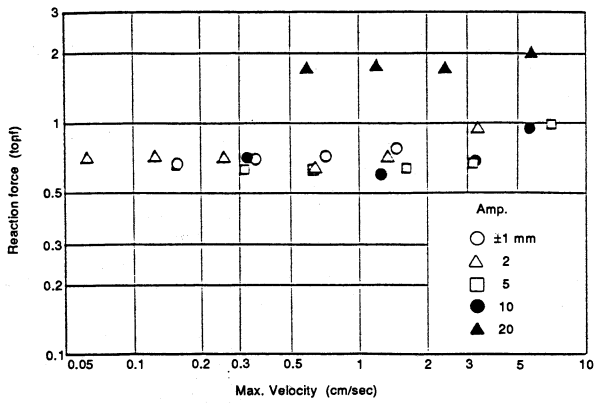

Fig. 6 Relationship between Reaction Force and Max. Velocity (Cylinder type)

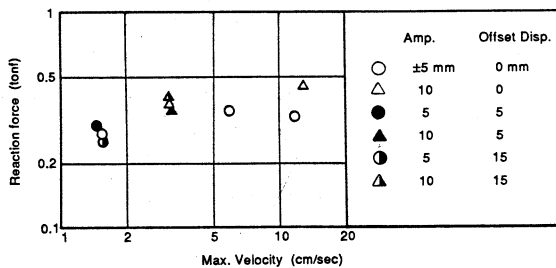

Fig. 7 Relationship between Reaction Force and Max. Velocity (Rotary type)

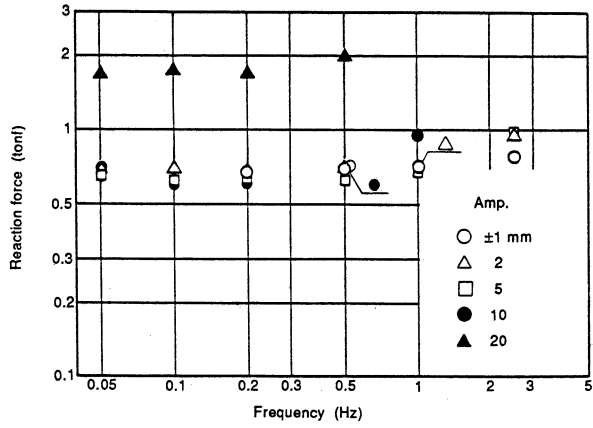

Fig. 8 Relationship between Reaction Force and Frequency (Cylinder type)

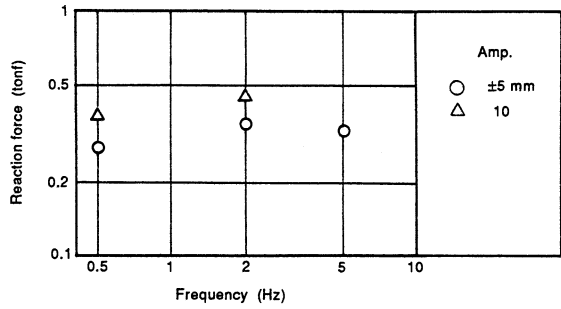

Fig. 9 Relationship between Reaction Force and Frequency (Rotary Type)

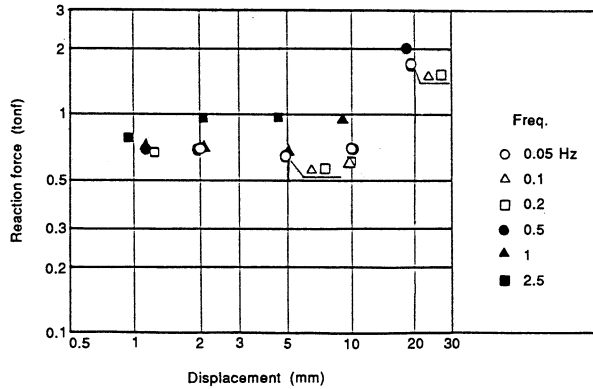

Fig. 10 Relationship between Reaction Force and Displacement (Cylinder type)

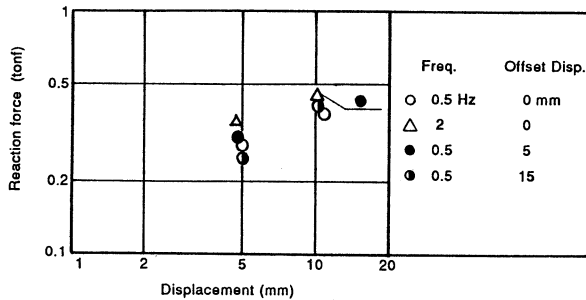

Fig. 11 Relationship between Reaction Force and Displacement (Rotary type)

