

Dynamic modeling of problem drinkers undergoing behavioral treatment

H. T. Banks, Kidist Bekele-Maxwell, R. A. Everett and Lyric Stephenson
Center for Research in Scientific Computation
North Carolina State University
Raleigh, NC 27695-8212 USA

and

Sijing Shao and Jon Morgenstern
Northwell Health
1010 Northern Blvd.
Great Neck, NY 11021 USA

October 30, 2016

Abstract

We use dynamical systems modeling to help understand how selected intra-personal factors interact to form mechanisms of behavior change in problem drinkers. Our modeling effort illustrates the iterative process of modeling using an individual's clinical data. Due to the lack of previous work in modeling behavior change in individual patients, we build our preliminary model relying on our psychological understandings of the relationships among the variables. This model is refined and the psychological understanding is then enhanced through the iterative modeling process. Our results suggest that this is a promising direction in research in alcohol use disorders as well as other behavioral sciences.

Key words: Mathematical psychology, inverse problems, generalized least squares, behavior change, personalized medicine.

1 Introduction

Excessive alcohol use causes about 1 in 10 deaths in working adults aged 20 - 64 years old [21] and costs the US approximately \$249 billion [19]. Excessive drinking includes binge drinking, heavy drinking, underage drinking, and alcohol use by pregnant women and can lead to numerous health problems [8]. Drinking excessively over time can eventually lead to an alcohol use disorder (AUD), which can range from mild to severe. The National Institute on Alcohol Abuse and Alcoholism (NIAAA) defines a low risk for an AUD for women as no more than 3 drinks in a day and 7 in a week, and for men as no more than 4 drinks in a day and 14 in a week [16].

Treatment options for alcohol use disorders include behavioral treatment through counseling, medications, and support groups. The overwhelming majority of AUD treatment is delivered in special-

ized substance abuse treatment programs that are designed to treat severe and chronic alcohol and drug problems [10]. Most AUD cases are mild to moderate and individuals with this severity are called problem drinkers (PDs). PDs often have a higher level of psychosocial functioning compared to severe alcohol dependence and often prefer moderation rather than abstinence as a treatment goal [13]. Since PDs represent a large portion of AUD cases and only less than 10% of mild AUD cases ever seek treatment [15], developing new techniques to treat PDs in the mainstream health care setting is an important public health priority.

In order to improve the effectiveness of behavioral therapy, a new research direction in personalized medicine is to gain a better understanding of the mechanism of behavior change in individuals. Through substance abuse research, factors have been identified as relating to changes in drinking behavior. These factors are categorized into stable and/or personalized characteristics, mood and affect, environmental factors, and internal process factors [3]. However, it is still unclear how these factors interact and form mechanisms of behavior change.

Mathematical modeling is one approach to understanding social behavior. The book [18], contains several examples of the use of mathematics to model human development, such as using a predator-prey model to understand human cerebral development and modeling adult clapping as a coupled oscillator. Oscillator models have also been used to model other human behaviors and emotions: Chow *et al.* [9] use a damped oscillator model to explain emotion regulation; Bisconti *et al.* [5] use an oscillator model to describe the emotional state of widows; Montpetit *et al.* [12] model negative affect and stress using coupled damped linear oscillator models; and Boker and Laurenceau [6] use undamped linear oscillators to model the intimacy between husbands' and wives'. In the context of drinking, Sanchez *et al.* [20] model drinking on the population level using the classic Susceptible-Infected-Recovered (SIR) epidemic model in order to understand mechanisms that cause people to move from a non-drinking population to a drinking population. Recently, there has been a shift from modeling on the inter-individual or population level to the intra-individual scale [7, 11]. Banks *et al.* [3] use a novel dynamical systems modeling approach to understand behavior change within problem drinkers. The authors use a "top-down" approach, where they start modeling several factors or variables for individual patients and then simplify the models by focusing on only a few variables using clinical data. This initial modeling effort emphasized the difficulty of this problem, particularly due to the lack of previous work considering inter- and intra- personal factors relating to behavior change in individual patients.

We build on the work of Banks *et al.* and use dynamical systems modeling to help understand the interactions among important factors and how these interactions change over time. We compare our model to clinical data from a problem drinker undergoing behavior change therapy. Although not all problem drinkers will have the same interactions and mechanisms at work during treatment, we believe that there are groups or cohorts of patients who have similar underlying mechanisms of behavior change. The methods for the clinical data collection are discussed in Section 2. In Section 3 we present the inverse problem methodology for estimating the parameter values of the mathematical model using clinical data. This is followed by the methodology and results for determining the correct statistical error model in Section 4. In Section 5 we present our preliminary model and then our revised model is presented in Section 6. Lastly, we discuss our conclusions and ideas for future work in Section 7.

2 Clinical Data and Variable Identification

We compare our mathematical model to clinical data from a study presented in [13] that compares the effectiveness of naltrexone (NTX), modified behavioral self-control therapy (MBSCT), or a combination of both in reducing alcohol consumption in PDs. NTX is a medication that is thought to reduce the rewarding effects of alcohol. MBSCT consists of a combination of motivational interviewing and cognitive behavioral skill training for reducing drinking to a moderate level. MBSCT is thought to work via increasing motivation to change and mastering of skills to avoid heavy drinking. Data were collected on 200 problem drinking men who have sex with men and are between the ages of 18 to 65 years old. These men were required to have consumed an average of at least 24 standard drinks per week for the 90 days prior to the study. The participants were randomized into one of four groups: NTX and MBSCT, NTX only, MBSCT only, and placebo [13].

The treatment occurred for 12 weeks during which ecological momentary assessment (EMA) data were collected. In general, EMA data are collected by sampling an individual's behavior repeatedly in almost real-time through the use of technology, such as a mobile phone. Thus EMA can monitor a change over time within a person, or an intra-individual change. In the clinical study in [13], the participants completed a daily telephone survey at the end of each day, answering 45 questions regarding their daily activities, number of alcoholic drinks consumed in the past 24 hours, and other factors relating to drinking behavior, such as confidence and commitment to resist drinking heavily in the next 24 hours. At the end of the treatment period, the patients were also asked to recall the number of drinks consumed each day of the 12-week treatment period. This type of data is called Time-Line-Follow-Back. Since this data does not measure intra-individual factors relating to behavior change, we compare our mathematical model only to the EMA data.

In the “top-down” approach used in [3], variables were first chosen for an individual patient only if the data for those variables appeared to be related to the data measuring the number of drinks consumed. Relationships among the variables that were not directly related to alcohol consumption were not considered. Here, we identify a few key variables and try to understand how these variables affect alcohol consumption and interact with each other over time to form behavior change. The four key variables that we consider are *alcohol consumption*, *norm violation*, *confidence*, and *commitment*. Alcohol consumption is measured by the total number of standard drinks a patient consumes in the past 24 hours. Since the survey is completed each evening, the past 24 hours includes the previous evening and the current day. The remaining three variables, *norm violation*, *confidence*, and *commitment*, are measured by the following questions from the daily survey, respectively.

Do you consider the total amount you have had to drink since this time yesterday to be excessive? That is, was it more than you think you should have had?

0 = definitely not

1 = possibly

2 = probably

3 = definitely

On a scale of 0 to 4 where:

0 = not at all

1 = somewhat

2 = moderately

3 = very

4 = extremely

How confident are you that you can resist drinking heavily (that is, resist drinking more than 5 drinks) over the next 24 hours?

On a scale of 0 to 4 where:

0 = not at all

1 = somewhat

2 = moderately

3 = very

4 = extremely

How committed are you not to drink heavily (that is, not to drink more than 5 drinks) over the next 24 hours?

Alcohol consumption was chosen since the goal of the treatment is for patients to reduce their drinking. Norm violation was selected as it was modeled in Banks *et al.* and is thought to be strongly related to behavior change. We considered confidence since it is also thought to be an important factor related to behavior change and since previous results by Morgenstern *et al.* [14] indicate that lack of confidence and commitment are predictors of drinking in the next 24 hours. We did not consider commitment at first for simplicity. However upon the first modeling iterations, it became clear that confidence requires the presence of commitment in order to affect alcohol consumption. Therefore, we determined that alcohol consumption, norm violation, confidence, and commitment were all essential for modeling behavior change in problem drinkers.

Since we are modeling intra-personal factors related to behavior change, we compare our model solutions to a dataset from a patient. To select a patient, we use latent-class growth analysis (LCGA), a well-known statistical method, in order to determine cohorts based on the change in number of heavy drinking days (HDD) per week over the treatment period. We then choose the cohort with the largest reduction in HDD throughout the treatment period. We select patient ID (PID) 1761 from this cohort since he successfully reduces his drinking from a problematic to an acceptable level. The EMA data measuring the four variables for this patient are shown in Figure 1. From the data we can see that PID 1761 successfully reduces his drinking from approximately 15 drinks per day to approximately 1 drink per day. His norm violation reduces from a level of 3 (the highest possible value) to 0 (the lowest possible value). Similarly, his confidence and commitment both increase to the highest possible value of 4 over the treatment period. Therefore, we believe that this patient changes his behavior during the 12 weeks of treatment and use his dataset to begin investigating mechanisms of behavior change in problem drinkers.

3 Inverse Problem Methodology

We use our mathematical model and clinical data to perform an inverse problem in order to estimate the parameters in the model for the individual patient ID 1761. Here, following [2, 4], we present the methodology of the inverse problem for the following general dynamical model

$$\begin{aligned}\frac{d\mathbf{x}}{dt}(t) &= \mathbf{g}(t, \mathbf{x}(t); \mathbf{q}), \\ \mathbf{x}(t_0) &= \mathbf{x}_0,\end{aligned}$$

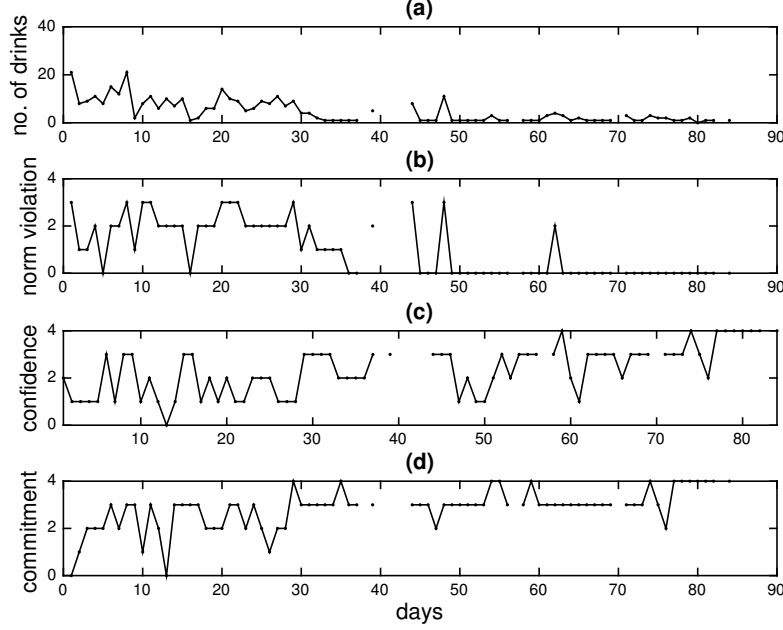

Figure 1: PID 1761 sample EMA data for alcohol consumption (a), norm violation (b), confidence (c), and commitment (d).

where \mathbf{x} represents an N -dimensional vector of state variables and $\boldsymbol{\theta} = [\mathbf{q}, \mathbf{x}_0]$ represents the p parameters (including the initial conditions) to be estimated in the mathematical model. Let \mathbf{y}_j represent the data or observations collected at time t_j , for $j = 1, \dots, n$. Define the m -dimensional observation process

$$\mathbf{f}(t; \boldsymbol{\theta}) = \mathcal{C}\mathbf{x}(t; \boldsymbol{\theta}),$$

where \mathcal{C} is an $m \times N$ matrix. This observational process represents the observed parts of the solution of the mathematical model. In order to handle the uncertainty in the observations, we consider the following statistical error model

$$\mathbf{Y}_j = \mathbf{f}(t_j; \boldsymbol{\theta}_0) + \mathbf{h}_j \circ \boldsymbol{\mathcal{E}}_j, \quad j = 1, \dots, n. \quad (1)$$

The $p \times 1$ vector $\boldsymbol{\theta}_0$ represents the “true” or nominal parameter set that generates \mathbf{Y}_j and we assume that $\boldsymbol{\theta}_0$ exists. Given a $\boldsymbol{\gamma} = (\gamma_1, \dots, \gamma_m)$, $\gamma_i \geq 0$, $i = 1, \dots, m$, we define the $m \times 1$ vector

$$\mathbf{h}_j = (f_1^{\gamma_1}(t_j; \boldsymbol{\theta}_0), \dots, f_m^{\gamma_m}(t_j; \boldsymbol{\theta}_0))^T.$$

The term $\mathbf{h}_j \circ \boldsymbol{\mathcal{E}}_j$ denotes component-wise multiplication of \mathbf{h}_j and the $m \times 1$ random vector $\boldsymbol{\mathcal{E}}_j$, and represents the measurement error or some other phenomena that causes the data to not exactly equal $\mathbf{f}(t_j; \boldsymbol{\theta}_0)$. We assume $\boldsymbol{\mathcal{E}}_j$ are independent and identically distributed (*i.i.d*) with mean zero. For a fixed j , $\text{Var}(\boldsymbol{\mathcal{E}}_{ij}) = \sigma_{0,i}^2$, for $i = 1, \dots, m$. The corresponding realization is given by

$$\mathbf{y}_j = \mathbf{f}(t_j; \boldsymbol{\theta}_0) + \mathbf{h}_j \circ \boldsymbol{\epsilon}_j, \quad j = 1, \dots, n.$$

The simplest form of \mathbf{h}_j is when $\boldsymbol{\gamma} = \mathbf{0}$ and so $\mathbf{h}_j = (1, \dots, 1)^T$. In this case, the statistical error model (1) is called the absolute error model and an ordinary least squares (OLS) method is appropriate for parameter estimation. If the error depends on the size of the observations, then $\boldsymbol{\gamma} \neq \mathbf{0}$ and a generalized least squares (GLS) method is appropriate.

Consider the more general GLS method. Then we have the following realizations of the statistical error models for observables $\mathbf{f}(t_j; \boldsymbol{\theta}_0) = (f_1(t_j; \boldsymbol{\theta}_0), f_2(t_j; \boldsymbol{\theta}_0), \dots, f_m(t_j; \boldsymbol{\theta}_0))^T$

$$\begin{aligned} y_{1,j} &= f_1(t_j; \boldsymbol{\theta}_0) + f_1(t_j; \boldsymbol{\theta}_0)^{\gamma_1} \epsilon_{1,j} \\ y_{2,j} &= f_2(t_j; \boldsymbol{\theta}_0) + f_2(t_j; \boldsymbol{\theta}_0)^{\gamma_2} \epsilon_{2,j} \\ &\vdots \\ y_{m,j} &= f_m(t_j; \boldsymbol{\theta}_0) + f_m(t_j; \boldsymbol{\theta}_0)^{\gamma_m} \epsilon_{m,j}, \end{aligned}$$

where $y_{i,j}$ represents data collected at time j for observable i , for $j = 1, \dots, n$.

In order to estimate the “true” parameter set from a set of possible parameters, Ω , we minimize the following GLS cost functional

$$J(\mathbf{Y}, \boldsymbol{\theta}) = \sum_{j=1}^n [\mathbf{Y}_j - \mathbf{f}(t_j; \boldsymbol{\theta})]^T V_0^{-1}(t_j) [\mathbf{Y}_j - \mathbf{f}(t_j; \boldsymbol{\theta})],$$

where

$$V_0(t_j) = \text{Var}(\mathbf{Y}_j) = W_0(t_j) \tilde{V}_0 = \text{diag}(\sigma_{0,1}^2 f_1(t_j; \boldsymbol{\theta}_0)^{2\gamma_1}, \dots, \sigma_{0,m}^2 f_m(t_j; \boldsymbol{\theta}_0)^{2\gamma_m}),$$

with

$$W_0(t_j) = \text{diag}(f_1(t_j; \boldsymbol{\theta}_0)^{2\gamma_1}, \dots, f_m(t_j; \boldsymbol{\theta}_0)^{2\gamma_m}), \quad \tilde{V}_0 = \text{Var}(\boldsymbol{\epsilon}_j) = \text{diag}(\sigma_{0,1}^2, \dots, \sigma_{0,m}^2).$$

This cost functional can be viewed as minimizing the distance between the data and the model output for each observable, where the observables are weighted according to their variability. For each observable i , the observations over time are weighted unequally. Then the GLS random variable is given by

$$\boldsymbol{\theta}_{GLS} = \arg \min_{\boldsymbol{\theta} \in \Omega} \sum_{j=1}^n [\mathbf{Y}_j - \mathbf{f}(t_j; \boldsymbol{\theta})]^T V_0^{-1}(t_j) [\mathbf{Y}_j - \mathbf{f}(t_j; \boldsymbol{\theta})],$$

with corresponding realization

$$\begin{aligned} \hat{\boldsymbol{\theta}}_{GLS} &= \arg \min_{\boldsymbol{\theta} \in \Omega} \sum_{j=1}^n [\mathbf{y}_j - \mathbf{f}(t_j; \boldsymbol{\theta})]^T V_0^{-1}(t_j) [\mathbf{y}_j - \mathbf{f}(t_j; \boldsymbol{\theta})] \\ &= \arg \min_{\boldsymbol{\theta} \in \Omega} \left(\sum_{j=1}^n \frac{1}{\sigma_{0,1}^2 f_1(t_j; \boldsymbol{\theta})^{2\gamma_1}} [y_{1,j} - f_1(t_j; \boldsymbol{\theta})]^2 + \dots + \sum_{j=1}^n \frac{1}{\sigma_{0,m}^2 f_m(t_j; \boldsymbol{\theta})^{2\gamma_m}} [y_{m,j} - f_m(t_j; \boldsymbol{\theta})]^2 \right). \end{aligned}$$

Since $\tilde{V}_0 = \text{diag}(\sigma_{0,1}^2, \dots, \sigma_{0,m}^2)$ is generally unknown, we approximate $\sigma_{0,i}^2$ with the estimate

$$\hat{\sigma}_{0,i}^2 = \frac{1}{n-p} \sum_{j=1}^n \frac{1}{f_i(t_j; \hat{\boldsymbol{\theta}}_{GLS})^{2\gamma_i}} [y_{i,j} - f_i(t_j; \hat{\boldsymbol{\theta}}_{GLS})]^2$$

and approximate $W_0(t_j)$ with

$$\hat{W}_j = \text{diag}(f_1(t_j; \hat{\boldsymbol{\theta}}_{GLS})^{2\gamma_1}, \dots, f_m(t_j; \hat{\boldsymbol{\theta}}_{GLS})^{2\gamma_m}).$$

Then $V_0(t_j) = W_0(t_j)\tilde{V}_0 = \text{diag}(\sigma_{0,1}^2 f_1(t_j; \boldsymbol{\theta}_0)^{2\gamma_1}, \dots, \sigma_{0,m}^2 f_{m,j}(t_j; \boldsymbol{\theta}_0)^{2\gamma_m})$ is approximated by the following

$$\begin{aligned} \hat{V}(t_j) &= \text{diag} \left(\frac{1}{n-p} \hat{W}_j \left(\sum_{j=1}^n [\mathbf{y}_j - \mathbf{f}(t_j; \hat{\boldsymbol{\theta}}_{GLS})][\mathbf{y}_j - \mathbf{f}(t_j; \hat{\boldsymbol{\theta}}_{GLS})]^T \hat{W}_j^{-1} \right)_{ii} \right) \\ &= \text{diag} \left(\frac{1}{n-p} \left(f_1(t_j; \hat{\boldsymbol{\theta}}_{GLS})^{2\gamma_1} \sum_{j=1}^n \frac{[y_{1,j} - f_1(t_j; \hat{\boldsymbol{\theta}}_{GLS})]^2}{f_1(t_j; \hat{\boldsymbol{\theta}}_{GLS})^{2\gamma_1}}, \dots, f_m(t_j; \hat{\boldsymbol{\theta}}_{GLS})^{2\gamma_m} \sum_{j=1}^n \frac{[y_{m,j} - f_m(t_j; \hat{\boldsymbol{\theta}}_{GLS})]^2}{f_m(t_j; \hat{\boldsymbol{\theta}}_{GLS})^{2\gamma_m}} \right)^T \right). \end{aligned}$$

Therefore, to numerically determine $\hat{\boldsymbol{\theta}}_{GLS}$, we want to solve the following coupled system

$$\hat{\boldsymbol{\theta}}_{GLS} = \arg \min_{\boldsymbol{\theta} \in \Omega} \sum_{j=1}^n [\mathbf{y}_j - \mathbf{f}(t_j; \boldsymbol{\theta})]^T \hat{V}^{-1}(t_j) [\mathbf{y}_j - \mathbf{f}(t_j; \boldsymbol{\theta})] \quad (2)$$

$$\hat{V}(t_j) = \text{diag} \left(\frac{1}{n-p} \hat{W}_j \left(\sum_{j=1}^n [\mathbf{y}_j - \mathbf{f}(t_j; \hat{\boldsymbol{\theta}}_{GLS})][\mathbf{y}_j - \mathbf{f}(t_j; \hat{\boldsymbol{\theta}}_{GLS})]^T \hat{W}_j^{-1} \right)_{ii} \right) \quad (3)$$

using the following iterative procedure [2, 4]:

1. Obtain the first estimate $\hat{\boldsymbol{\theta}}_{GLS}^{(0)}$ using equation (2) with $\hat{V}(t_j) = I$. Set $k = 0$.
2. Calculate the weights $\hat{W}_j = \text{diag} \left(f_1(t_j; \hat{\boldsymbol{\theta}}_{GLS}^{(k)})^{2\gamma_1}, \dots, f_m(t_j; \hat{\boldsymbol{\theta}}_{GLS}^{(k)})^{2\gamma_m} \right)$.
3. Solve for $\hat{V}^{(k)}(t_j)$ using \hat{W}_j and $\hat{\boldsymbol{\theta}}_{GLS}^{(k)}$ in equation (3).
4. Estimate $\hat{\boldsymbol{\theta}}_{GLS}^{(k+1)}$ using $\hat{V}^{(k)}(t_j)$ in equation (2).
5. Set $k = k + 1$ and return to step 2. Continue the iteration until two successive estimates are sufficiently close and set $\hat{\boldsymbol{\theta}}_{GLS} = \hat{\boldsymbol{\theta}}_{GLS}^{(k+1)}$.

4 Determining the Statistical Error Model

In order to perform the inverse problem, we first need to determine the correct statistical error model (i.e., the correct value for $\boldsymbol{\gamma}$). One method is to guess a statistical error model, perform the inverse problem to obtain the estimated parameter set, and then use the residual plots to determine if the correct statistical model was used [2, 4]. However, this can require several guess-and-check iterations until the correct statistical model is determined, which can be computationally expensive since an inverse problem is performed for each guess. Additionally, if the mathematical model is not describing the desired process correctly, then residual plots can provide incorrect information. An alternative method is to apply second-order differencing directly on the data. Since this method does not depend on the mathematical model and does not involve inverse problems, it is a more accurate and efficient method for determining the correct statistical model [1].

To apply this method, we follow [1] and use second-order differencing to calculate the pseudo-

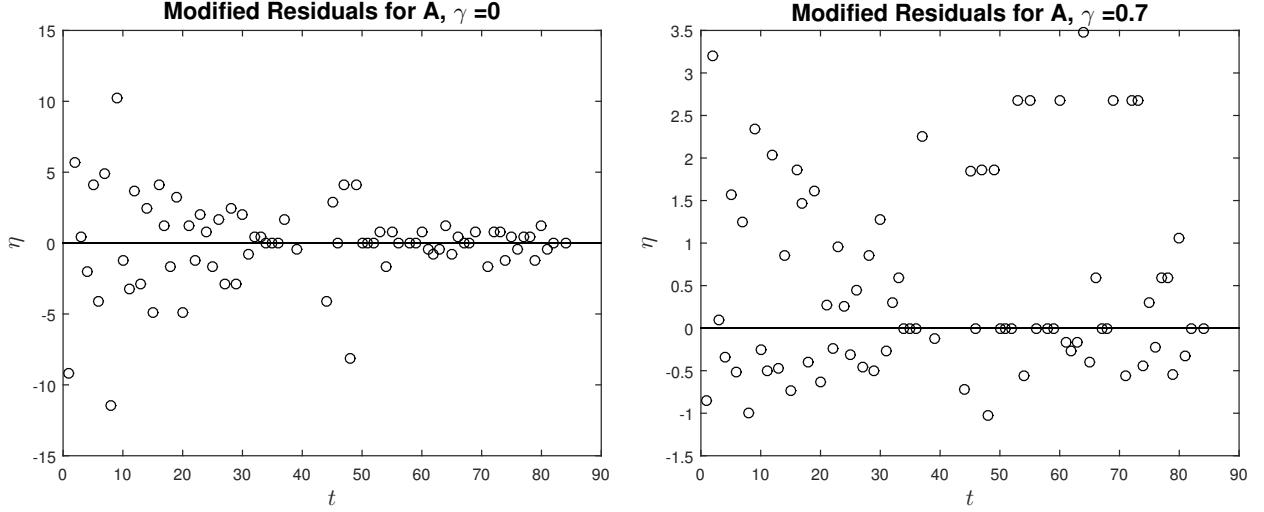

Figure 2: Modified residuals versus time for alcohol consumption with $\gamma = 0$ (left) and $\gamma = 0.7$ (right) values.

measurement errors

$$\hat{\varepsilon}_{i,j} = \begin{cases} \frac{1}{\sqrt{2}}(y_{i,j+1} - y_{i,j}), & j = 1 \\ \frac{1}{\sqrt{6}}(y_{i,j-1} - 2y_{i,j} + y_{i,j+1}), & j = 2, \dots, n-1 \\ \frac{1}{\sqrt{2}}(y_{i,j} - y_{i,j-1}), & j = n \end{cases}$$

for $i = 1, \dots, m$. We then calculate the modified residuals for different γ values. For each observation i , the modified residual at time t_j is defined as

$$\eta_j = \frac{\hat{\varepsilon}_j}{|y_j - \hat{\varepsilon}_j|^{\gamma_i}}.$$

By plotting the modified residuals η_j versus time t_j , we look for the γ_i value such that the scatter plot forms a horizontal band around the x -axis.

We tested various values of γ_i for each of the four variables: alcohol consumption, norm violation, confidence, and commitment. Figure 2 contains the scatter plots of the modified residuals η_j versus time t_j for alcohol consumption with $\gamma_1 = 0$ (left) and $\gamma_1 = 0.7$ (right). It is clear that the plot with $\gamma_1 = 0.7$ has the desired distribution whereas the plot with $\gamma_1 = 0$ has an undesired megaphone shape. For the variables norm violation, confidence, and commitment, the plots with $\gamma_i = 0$, $i = 2, 3, 4$, provide the desired distribution (Figure 3).

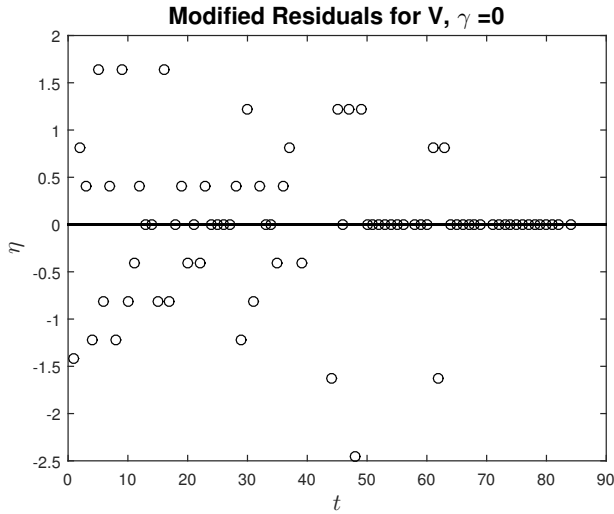

(a) Modified residuals plots for norm violation.

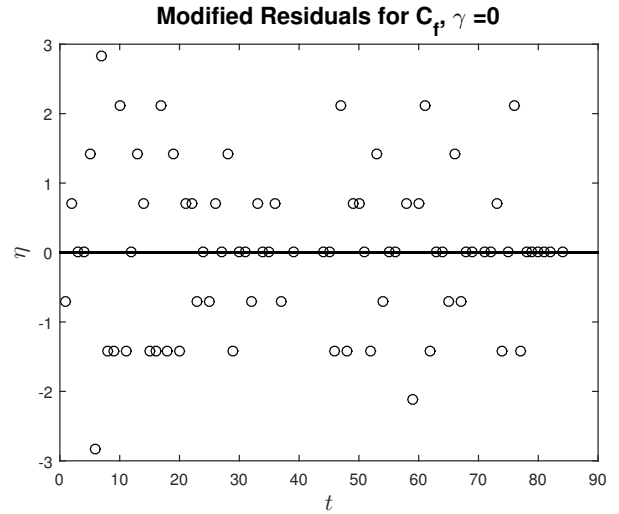

(b) Modified residuals plots for confidence.

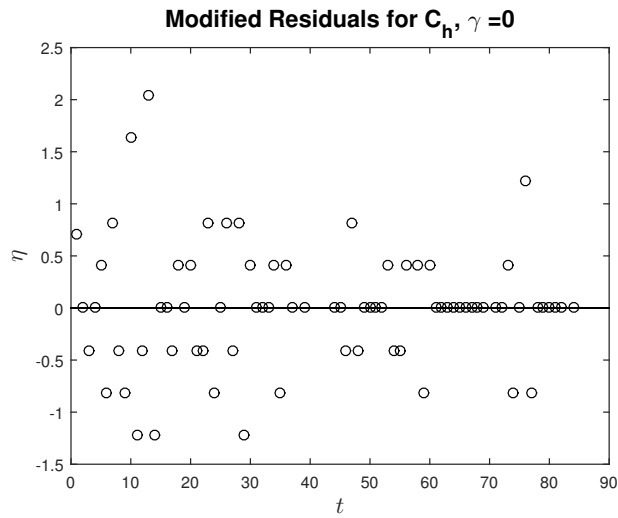

(c) Modified residuals plots for commitment.

Figure 3: Modified residuals versus time with $\gamma = 0$ for norm violation (a), confidence (b), and commitment (c).

5 Preliminary Model

With the correct statistical error model (γ value), we now proceed to build a mathematical model that represents the relationships among the variables. Let $A(t)$ represent alcohol consumption, or the number of drinks a person has consumed in the past 24 hours from time t (i.e., the amount of alcohol consumed from time $t - 1$ to time t). Let $V(t)$ represent norm violation, or the extent to which a person considers at time t that $A(t)$ was more than they should have consumed (i.e., the extent to which a person feels at time t that they violated their norm for alcohol consumption from time $t - 1$ to t). Let $C_f(t)$ represent the confidence a person feels at time t that they can resist drinking heavily in the next 24 hours (i.e., the confidence a person feels that they can resist drinking heavily from time t to time $t + 1$). Let $C_h(t)$ represent the commitment a person makes at time t to not drink heavily in the next 24 hours (i.e., the commitment a person makes to not drink heavily from time t to time $t + 1$). The following schematic in Figure 4 describes the timeline in which the variables are defined.

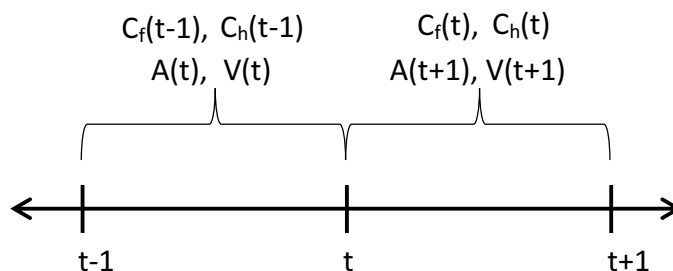

Figure 4: Timeline of variable definition.

We also consider a variable $A^*(t)$, which represents the number of drinks consumed in the past 24 hours from time t that a person believes is standard or their norm. We will simply refer to this variable as “personal norm”. Although the clinical study did not collect data about this variable, we believe it is an important intra-personal factor relating to mechanisms of behavior change. We assume that $A^*(t)$ decreases over time when the treatment is effective.

We start by creating a schematic to represent our understanding of the relationships among these variables (see Figure 5). We then use these hypothesized relationships to build a mathematical model of behavior change in problem drinkers (Model 4). Each term in the model is labeled with a number that represents the corresponding arrow in the schematic.

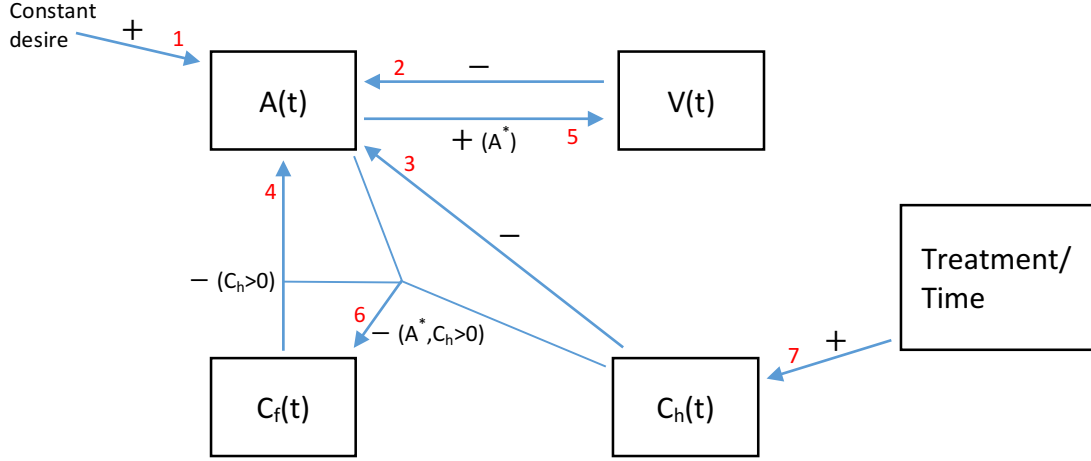

Figure 5: Schematic of hypothesized variable relationships.

Consider the following mathematical model

$$\frac{dA}{dt} = \underbrace{a_1}_1 - \underbrace{a_2 V(t-1)}_2 - \underbrace{a_3 C_h(t-1)}_3 - \underbrace{a_4 C_f(t-1) C_h(t-1)}_4 \quad (4a)$$

$$\frac{dV}{dt} = \underbrace{\chi_{(A > A^*)} v_1 (A - A^*)}_{5a} - \underbrace{\chi_{(A \leq A^*)} v_2 V}_{5b} \quad (4b)$$

$$\frac{dC_f}{dt} = \underbrace{d_1 (A^* - A) C_h(t-1)}_6, \quad (4c)$$

where

$$C_h(t) = \underbrace{\frac{mt}{K+t} + \beta}_7, \quad (4d)$$

$$A^*(t) = \underbrace{be^{-rt} + l}_8, \quad (4e)$$

and

$$\chi_{A > A^*} = \begin{cases} 1 & \text{if } A > A^* \\ 0 & \text{else} \end{cases}, \quad \chi_{A \leq A^*} = \begin{cases} 1 & \text{if } A \leq A^* \\ 0 & \text{else} \end{cases}. \quad (4f)$$

The given terms are explained by the following

1. A constant desire (or constant drive) to drink causes alcohol consumption to increase. This is represented by the parameter a_1 .
2. If the patient feels that his drinking in the past 24 hours was a norm violation, he will decrease his drinking in the next 24 hours. The parameter a_2 is a weighting parameter.
3. If the patient feels committed to not drink heavily in the next 24 hours, then he will decrease his drinking in the next 24 hours. The parameter a_3 is a weighting parameter.

4. If the patient feels both committed to not drink heavily in the next 24 hours as well as confident that he can resist drinking heavily in the next 24 hours, then he will decrease his drinking in the next 24 hours. Note that the patient needs to feel *both* confident and committed in order to decrease alcohol consumption. That is, if the patient feels confident but *definitely not* committed, then confidence will not cause a decrease in alcohol consumption. The parameter a_4 is a weighting parameter.
- 5a. If the patient drinks more than his personal norm ($A > A^*$) in 24 hours, then norm violation about that 24 hours will increase. The parameter v_1 is a weighting parameter.
- 5b. If the patient drinks less than or equal to his personal norm ($A \leq A^*$) in 24 hours, then his rate for norm violation will decrease. We assume here that this rate for norm violation is decreasing exponentially at rate v_2 .
6. If the patient drinks more than his personal norm ($A > A^*$) in the past 24 hours and the patient was committed to not drink heavily in the past 24 hours, then his confidence about the next 24 hours decreases. Similarly, if the patient drinks less than his personal norm ($A < A^*$) in the past 24 hours and the patient was committed to not drink heavily in the past 24 hours, then his confidence about the next 24 hours increases. Note that confidence decreases (or increases) only if the patient drank more (or less) than his personal norm and felt committed. If the patient was *definitely not* committed, then confidence will not change. The parameter d_1 is a weighting parameter.
7. If treatment is effective, then the patient's commitment will increase as the length of time in treatment increases. Here we model commitment using a bounded monotonically increasing function. The parameter m represents the bound as time goes to infinity. The parameter K represents the time at which $C_h = \frac{m}{2}$. The parameter β represents the initial value of commitment.
8. We assume that the patient's personal norm exponentially decreases over the treatment period at rate r . The parameter l represents the personal norm value as time goes to infinity. At time $t = 0$, $A^*(0) = b + l$.

Using this mathematical model where $\mathbf{f} = \mathbf{x} = [A, V, C_f, C_h]^T$ and the statistical model in equation (1) with $\boldsymbol{\gamma} = [0.7, 0, 0, 0]^T$, we perform the inverse problem to obtain the estimated parameters. The results are given in Figure 6. We can see that our psychological hypothesis represented by our model does not accurately describe the mechanisms of change undergoing in PID 1761 since the model solutions do not fit the data well. Particularly, the solutions for norm violation (Figure 6b) and confidence (Figure 6c) exhibit the wrong behavior; the norm violation solution increases for a long period of time before it decreases and the confidence solution decreases when it should be either remaining constant or increasing. These dynamics are easily explained by the model. We hypothesized that when A is larger than A^* , which occurs from day 0 to approximately day 64 in Figure 6, norm violation increases and confidence decreases. Therefore, we need to adjust these psychological assumptions.

After observing these results, we propose that a patient's norm violation does not simply depend on the difference between a patient's alcohol consumption and personal norm, but rather on the *rate* at which A approaches A^* , $\frac{d(A-A^*)}{dt}$. Even if a patient is drinking more than his personal norm, as long as the number of drinks is decreasing toward it, his norm violation should decrease. Similarly, a patient's confidence should depend on the *rate* of drinking rather than the difference between A and A^* . Recall that the variable confidence reflects how confident a patient feels that he can resist

drinking more than 5 drinks. Therefore, confidence should not depend on the personal norm but rather on the NIAAA heavy drinking threshold of 5 drinks.

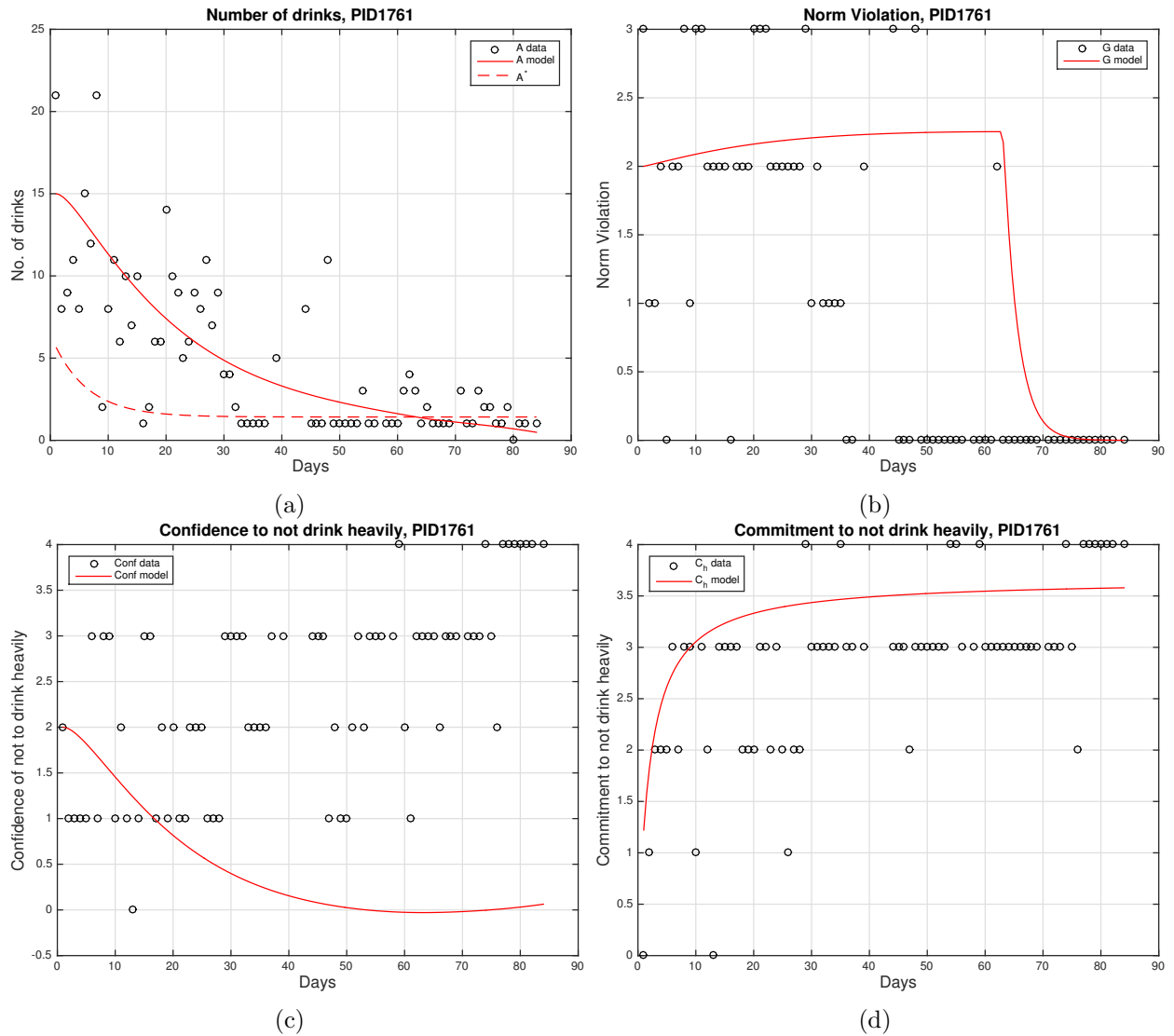

Figure 6: Model (4) solutions (red solid line) and data (black circles) for alcohol consumption (a), norm violation (b), confidence (c), and commitment (d). The personal norm, A^* , solution is plotted as a red dashed line in (a). Estimated parameter values are $a_1 = 0.001$, $a_2 = 0.013$, $a_3 = 0.012$, $a_4 = 0.087$, $v_1 = 0.001$, $v_2 = 0.404$, $d_1 = 0.003$, $b = 5.000$, $r = 0.166$, $l = 1.420$, $m = 3.664$, $k = 2.000$, $A_0 = 15$, $V_0 = 2$, $C_{f_0} = 2$, $\beta = 0.000$.

6 Revised Model

After refining our assumptions in the preliminary model, we update the schematic to include our new understanding of the relationships among these variables (see Figure 7).

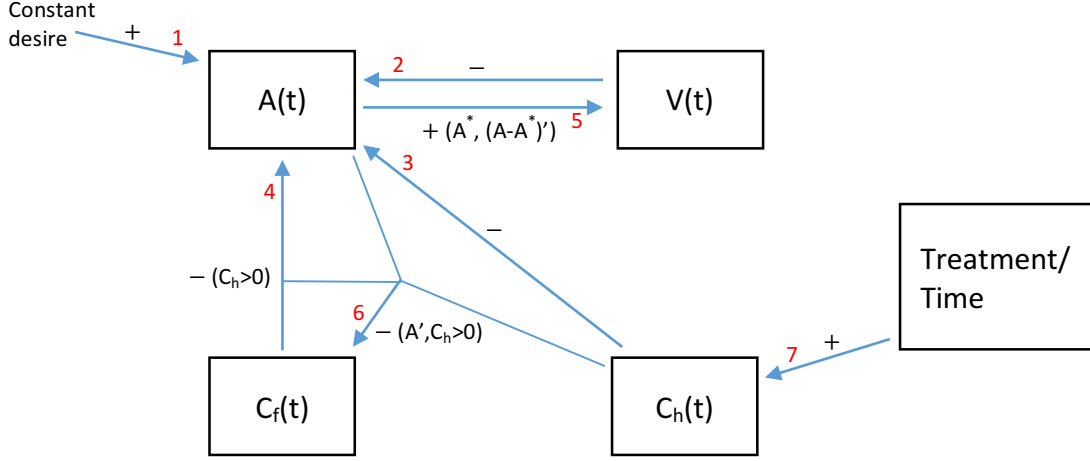

Figure 7: Revised schematic of hypothesized variable relationships.

Based on this schematic, we revise the model as follows

$$\frac{dA}{dt} = \underbrace{a_1}_1 - \underbrace{a_2 V(t-1)}_2 - \underbrace{a_3 C_h(t-1)}_3 - \underbrace{a_4 C_f(t-1) C_h(t-1)}_4 \quad (5a)$$

$$\frac{dV}{dt} = \underbrace{\chi_{(A > A^*)} v_1 \frac{d(A - A^*)}{dt}}_{5a} - \underbrace{\chi_{(A \leq A^*)} v_2 V}_{5b} \quad (5b)$$

$$\frac{dC_f}{dt} = \underbrace{-\chi_{(A > 5)} d_1 \frac{dA}{dt} C_h(t-1)}_{6a} + \underbrace{\chi_{(A \leq 5)} d_2 (C_f - \alpha) \left(1 - \frac{C_f}{4}\right)}_{6b}, \quad (5c)$$

where

$$C_h(t) = \frac{mt}{\underbrace{K + t}_7} + \beta \quad (5d)$$

$$A^*(t) = \underbrace{be^{-rt} + l}_8, \quad (5e)$$

and

$$\chi_{A > A^*} = \begin{cases} 1 & \text{if } A > A^* \\ 0 & \text{else} \end{cases}, \quad \chi_{A \leq A^*} = \begin{cases} 1 & \text{if } A \leq A^* \\ 0 & \text{else} \end{cases}. \quad (5f)$$

The modified terms are explained by the following:

- 5a. This term only contributes to the model when alcohol consumption in 24 hours is larger than the personal standard ($A > A^*$). As the distance between A and A^* increases over time, the extent to which the patient feels that he violated his norm will increase over time; as the distance between A and A^* decreases over time, the extent to which the patient feels that he violated his norm will decrease over time. The parameter v_1 is a weighting parameter.

- 6a. This term only contributes to the model when the patient is drinking heavily (more than 5 drinks in 24 hours). In this case, confidence changes based on the patient’s commitment to not drink heavily in the past 24 hours and the rate at which the patient is drinking. Note that confidence will only decrease (or increase) if the patient’s drinking rate is negative (or positive) and he was committed. If the patient was *definitely not* committed, then confidence will not change. The parameter d_1 is a weighting parameter.
- 6b. This term only contributes to the model when the patient is not drinking heavily ($A \leq 5$). In this case, the patient will first need to establish a habit of drinking less than 5 drinks before he feels a sense of mastery and his confidence increases to 4. We model this using a logistic function, whose graph has three regions (see Figure 8). In R1, confidence has slow growth and represents the time it takes for the patient to establish a habit of drinking less than 5 drinks. In R2, confidence quickly increases to the maximum confidence level and represents the time when the patient has established the habit and so he is feeling a sense of mastery. In R3, there again is slow growth since the patient has mastered his habit and has “reached” the maximum confidence level.

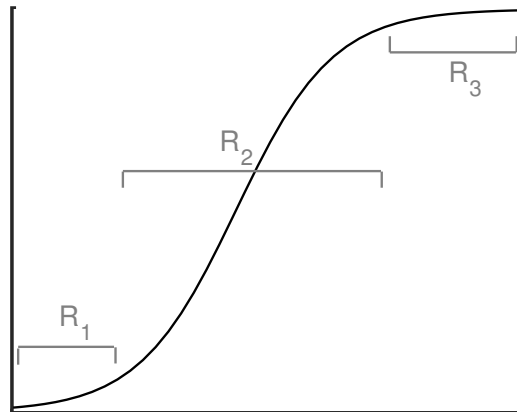

Figure 8: Logistic model

Since we want the logistic function to start once $A \leq 5$ (not at $t = 0$), we subtract the parameter α to shift the function to start approximately at the time that A reaches 5. Let \bar{t} be the first time $A \leq 5$ and let \bar{C}_f represent the confidence value at \bar{t} . Then for the model to be psychologically realistic, $\alpha < \bar{C}_f$. The closer α is to \bar{C}_f , the longer R1 will be, and the longer it takes the person to feel a sense of mastery (see Figure 9).

We again perform an inverse problem to estimate the parameters for PID 1761. The results are given in Figure 10. The model solutions reflect the dynamics observed in the data more accurately compared to the preliminary model solutions. When observing the data in Figure 10a, we can see that his drinking is usually high yet quite sporadic until around day 30, after which his drinking mostly remains below 5 drinks. Our model also highlights day 30, as this is approximately the first time the patient successfully decreases his drinking to his personal norm. While the number of drinks that he consumes generally stays low for the remaining time, the patient does have a few days of higher alcohol consumption (eg. days 39, 44, 48, and 62). This behavior is reflected by our model solution increasing back above the personal norm. Following the data, the model solution then continues to decrease until the end of the treatment period. In Figure 10b, we can see that

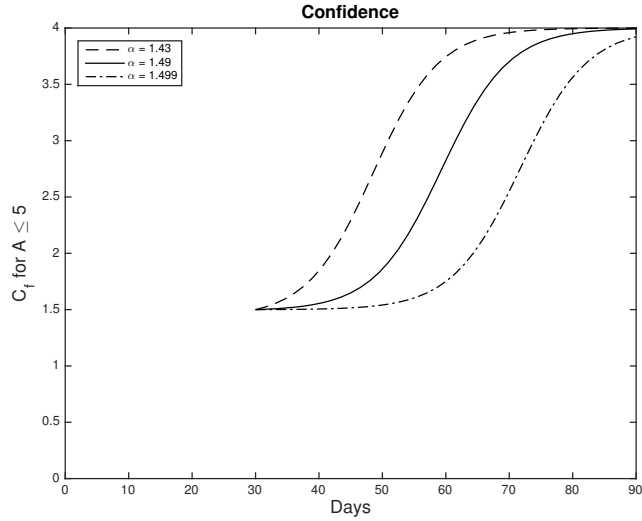

Figure 9: C_f when $A \leq 5$ at $\bar{t} = 30$ for $\bar{C}_f = 1.5$, $d_2 = .3$, and various α values.

during the first month, the patient's norm violation approximately remains around level 2, after which it decreases to 1 and then quickly to level 0. Our model captures this dynamic by slowly decreasing in the first month and then decreasing at a faster rate until around day 44. The solution then slowly increases before decreasing back to 0. This slow increase is caused by the small increase in alcohol consumption above the personal norm around the same time and reflects the high level of norm violation that the patient feels on days 39, 44, 48, and 62. Although the confidence data in Figure 10c is very sporadic, the patient does exhibit a general increase in confidence over the treatment period, which is reflected in our model solution. Similarly, the commitment solution in Figure 10d captures the general increasing trend of the data.

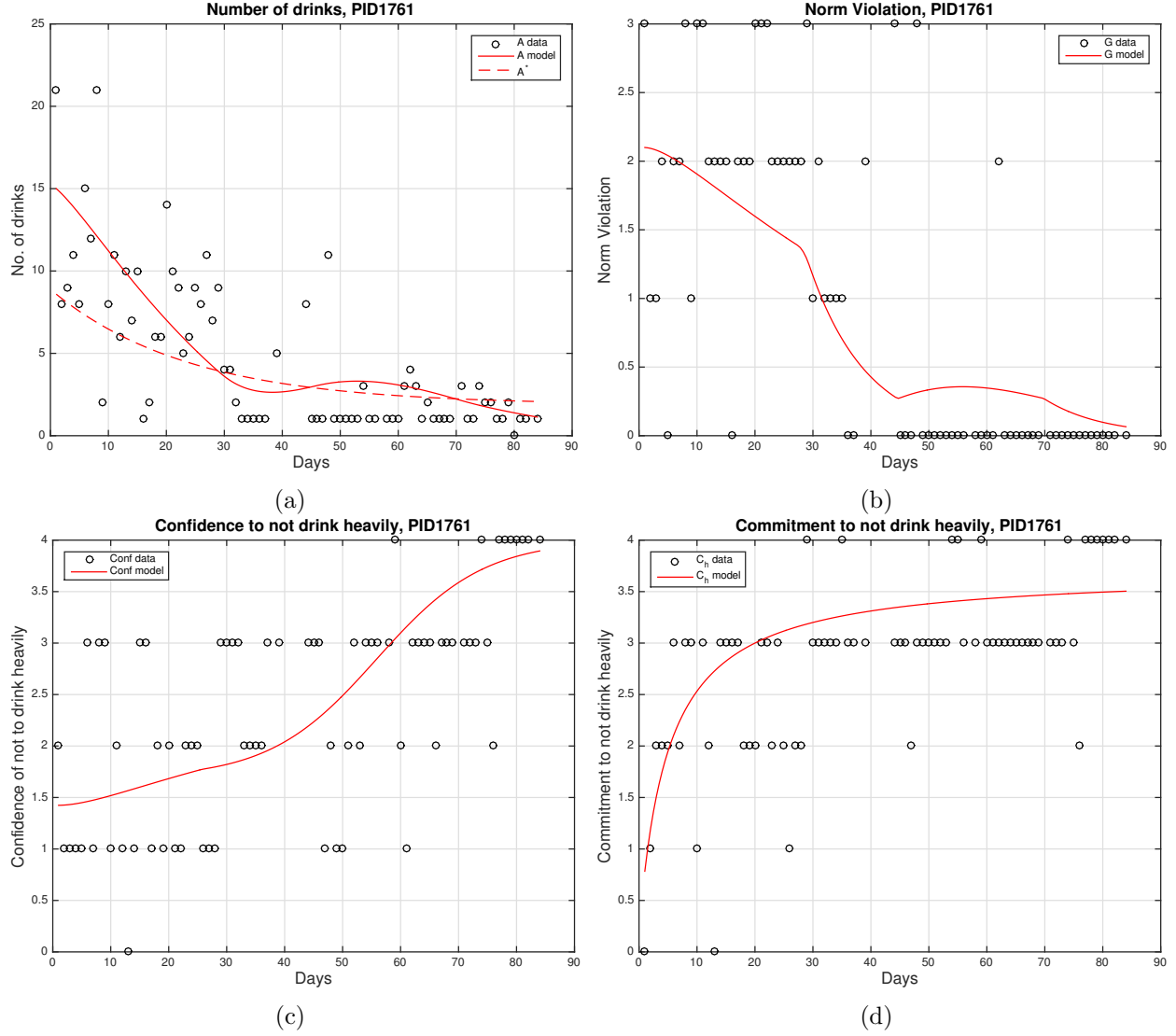

Figure 10: Model (5) solutions (red solid line) and data (black circles) for alcohol consumption (a), norm violation (b), confidence (c), and commitment (d). The personal norm, A^* , solution is plotted as a red dashed line in (a). Estimated parameters values are $a_1 = 0.600$, $a_2 = 0.423$, $a_3 = 0.038$, $a_4 = 0.037$, $v_1 = 0.117$, $v_2 = 0.100$, $d_1 = 0.014$, $d_2 = 0.187$, $b = 7.011$, $r = 0.042$, $l = 1.872$, $m = 3.501$, $k = 5.009$, $A_0 = 15.001$, $V_0 = 2.1$, $C_{f_0} = 1.424$, $\beta = 0.201$, $\alpha = 1.688$.

7 Discussion

We build on the work of Banks *et al.* [3] and use dynamical systems modeling to help understand how factors interact to form mechanisms of behavior change. The authors of [3] use a “top-down” approach where they model several variables for individual patients and then reduce the number of variables to simplify the model. In addition, the authors focus on only the variables with data that appeared to be directly related to alcohol consumption data. Here, we apply a “bottom-up” approach by focusing on the relationship among a few key variables: alcohol consumption, norm violation, confidence, and commitment. We also consider an additional variable, personal norm, for which there were no collected data.

Our modeling effort demonstrates the iterative process of modeling. We begin by proposing a psychological hypothesis through our preliminary model. We simulate this model and compare the results to the clinical data, which leads to an improved understanding of the relationships among the variables. We then repeat the cycle again by proposing a revised model that incorporates this new psychological understanding. The revised model solutions more accurately reflect the dynamics in the data compared to the preliminary model, which suggests that the revised model captures the relationships among the variables better. Our results indicate that the rate of change of alcohol consumption is dependent on norm violation, commitment, and confidence, although confidence requires the presence of commitment in order to affect alcohol consumption. Similarly, the rate of change of confidence is dependent upon the rate of change of alcohol consumption only when the patient is committed to not drink heavily. The rate of change of norm violation is dependent upon the rate at which A approaches A^* .

While our revised model produced improved results, there are certainly areas for improvement. PID 1761 reduced his drinking below a threshold of 5 drinks and remained below this level for the rest of the treatment period. One direction for future work would be to improve the model to accommodate patients whose alcohol consumption increases back above 5 drinks. With our current revised model, if a patient’s alcohol consumption increases above 5 drinks, his confidence will immediately decrease. However, from our psychological understanding, just as a patient needs to establish a habit of drinking less than 5 drinks before feeling a sense of mastery, a patient would need to establish a habit of drinking more than 5 drinks again before losing confidence. Since PID 1761 did not exhibit this behavior, this scenario is not included in the model. However, this additional psychological understanding may be important to model when considering other patients.

We believe that there are groups or cohorts of patients who have similar underlying mechanisms of behavior change and so future work includes comparing the revised model solutions to several patients’ data in order to form a cohort. In addition, considering different types of equations for A^* and C_h might produce more accurate results. Future work could also include considering more variables, such as desire (we assumed this to be constant), external events, or pressure.

When performing the inverse problem, we used MATLAB 2015a and the built-in function `fmincon` on a MacBook Pro with processor 2.8 GHz Intel Core i7. For the optimization solver, we provided initial guesses for the parameters based on heuristic and specified lower and upper bounds for each parameter to improve computational efficiency. Realistic bounds were chosen when possible and otherwise based on observation. The bounds were also restricted due to the fact that norm violation, confidence, and commitment are modeled as continuous variables, whereas the corresponding data are discrete ordinal. For example, it is doubtful that the patient feels a norm violation of exactly 2

and then jumps to a level of exactly 1, but rather the patient probably feels a continuous decrease from level 2 to level 1 and then to level 0. Our modeling effort attempts to understand this overall trend of behavior change rather than the day-to-day fluctuations. Thus, estimating parameters so that the model fits the data exactly would result in several horizontal lines and most likely be unrealistic. New data is currently being collected that includes more answer options (eg. the confidence will be measured on a scale of 0 to 8 rather than 0 to 4), which will improve the quality of the data.

Acknowledgements

This research was supported in part by the National Institute on Alcohol Abuse and Alcoholism under grant number 1R01AA022714-01A1, in part by the Air Force Office of Scientific Research under grant number AFOSR FA9550-15-1-0298, and in part by the National Science foundation under NSF Undergraduate Biomathematics grant number DBI-1129214.

References

- [1] H. T. Banks, J. Catenacci, and S. Hu, Use of difference-based methods to explore statistical and mathematical model discrepancy in inverse problems, *Journal of Inverse and Ill-posed Problems*, **24** (2016), 413–433.
- [2] H. T. Banks, S. Hu, and W. C. Thompson, *Modeling and Inverse Problems in the Presence of Uncertainty*, CRC Press, New York, 2014.
- [3] H. T. Banks, K. L. Rehm, K. L. Sutton, C. Davis, L. Hail, A. Kuerbis, and J. Morgenstern, Dynamic modeling of behavior change, *Quarterly of Applied Mathematics*, **72** (2014), 209–251.
- [4] H. T. Banks and H. T. Tran, *Mathematical and Experimental Modeling of Physical and Biological Processes*, CRC Press, New York, 2009.
- [5] T. L. Bisconti, C. S. Bergeman, and S. M. Boker, Emotional well-being in recently bereaved widows: a dynamical systems approach, *Journal of Gerontology: Psychological Sciences*, **59B** (2004), P158–P167.
- [6] S. M. Boker and J-P Laurenceau, Dynamical systems modeling: an application to the regulation of intimacy and disclosure in marriage. In T. A. Walls and J. L. Schafer (Eds.), *Models for Intensive Longitudinal Data* (195–218), Oxford University Press, Inc., New York, 2006.
- [7] S. M. Boker, P. C. M. Molenaar, and J. R. Nesselroade, Issues in intraindividual variability: individual differences in equilibria and dynamics over multiple time scales, *Psychology and Aging*, **24** (2009), 858–862.
- [8] Centers for Disease Control and Prevention, Alcohol use and your health, <http://www.cdc.gov/alcohol/fact-sheets/alcohol-use.htm>, (2016).
- [9] S-M Chow, N. Ram, S. M. Boker, F. Fujita, and G. Clore, Emotion as a thermostat: representing emotion regulation using a damped oscillator model, *American Psychological Association*, **5** (2005), 208–225.
- [10] A. T. McLellan, D. Carise, and H. D. Kleber, Can the national addiction treatment infrastructure support the public’s demand for quality care?, *Journal of Substance Abuse Treatment*, **25** (2003), 117–121.
- [11] P. C. M. Molenaar and C. G. Campbell, The new person-specific paradigm in psychology, *Current Directions in Psychological Science*, **18** (2009), 112–117.
- [12] M. A. Montpetit, C. S. Bergeman, P. R. Deboeck, S. S. Tiberio, and S. M. Boker, Resilience-as-process: negative affect, stress, and coupled dynamical systems, *Psychology and Aging*, **25** (2010), 631–640.
- [13] J. Morgenstern, A. N. Kuerbis, A. C. Chen, C. W. Kahler, D. A. Bux Jr., and H. R. Kranzler, A randomized clinical trial of naltrexone and behavioral therapy for problem drinking men who have sex with men, *Journal of Consulting and Clinical Psychology*, **80** (2012), 863–875.
- [14] J. Morgenstern, A. Kuerbis, J. Houser, F. Muench, S. Shao, H. Treloar, Within-person associations between daily motivation and self-efficacy and drinking among problem drinkers in treatment, *Psychology of Addictive Behaviors*, **30** (2016), 630–638.

- [15] H. B. Moss, C. M. Chen, and H-Y Yi, Subtypes of alcohol dependence in a nationally representative sample, *Drug and Alcohol Dependence*, **91** (2007), 149–158.
- [16] National Institute for Alcohol Abuse and Alcoholism, Alcohol facts and statistics, <https://www.niaaa.nih.gov/alcohol-health/overview-alcohol-consumption/alcohol-facts-and-statistics>, (2016).
- [17] National Institute for Alcohol Abuse and Alcoholism, Alcohol use disorder, <https://www.niaaa.nih.gov/alcohol-health/overview-alcohol-consumption/alcohol-use-disorders>.
- [18] K. M. Newell and P. C. M. Molenaar, *Applications of Nonlinear Dynamics to Developmental Process Modeling*, Lawrence Erlbaum Associates, Inc., New Jersey, 1998.
- [19] J. Sacks, K. R. Gonzales, E. E. Bouchery, L. E. Tomedi, and R. D. Brewer, 2010 national and state costs of excessive alcohol consumption, *American Journal of Preventive Medicine*, **49** (2015), e73–e79.
- [20] F. Sánchez, X. Wang, C. Castillo-Chávez, D. M. Gorman, and P. J. Gruenewald, Drinking as an epidemic - a simple mathematical model with recovery and relapse. In K. Witkiewitz and G. A. Marlatt (Eds)., *Therapist's Guide to Evidence-Based Relapse Prevention* (353–368), Elsevier Inc., San Diego, 2007.
- [21] M. Stahre, J. Roeber, D. Kanny, R. D. Brewer, and X. Zhang, Contribution of excessive alcohol consumption to deaths and years of potential life lost in the United States, *Preventing Chronic Disease*, **11** (2014), 11:130293. DOI: <http://dx.doi.org/10.5888/pcd11.130293>.