

ELASTIC AND ELASTIC-PLASTIC BUCKLING OF VESSEL HEADS COMPUTATION BY THE CEASEMT SYSTEM

B. CANTON

Institut Universitaire de Technologie, F-00000 Cachan, France

A. HOFFMANN, R. L. ROCHE

*Commissariat à l'Énergie Atomique, Centre d'Études Nucléaires de Saclay,
Département des Études Mécaniques et Thermiques, B.P. n° 2, F-91190 Gif-sur-Yvette, France*

C. TROCLET

École Nationale Supérieure Mécanique et Aéronautique, F-00000 Poitiers, France

SUMMARY

In Liquid Metal Fast Breeder Reactors of integrated type, the sodium pressure is low, but the dimensions are large. The thickness-diameter ratios are rather smaller than in other type of nuclear pressure vessels. Therefore buckling must be considered as a potential mode of failure. For instance, the bottom head of the main vessel is loaded by internal hydrostatic pressure and dead weights, and there is a need for buckling analysis. It must be pointed out that in practical cases, buckling occurs after plastic deformation.

Due to the effect of initial imperfections elastic buckling is rather difficult to analyse. Moreover, elastic-plastic buckling theory is not a very clear theory and consideration must be given to finite deflexions (and perhaps to initial stresses). So the choice of a suitable mathematical model is a matter of good engineering judgment.

In the CEASEMT system of structural analysis by finite element method, a special program has been developed for that purpose. The model chosen (MOTAN) is near a tangent modulus model, because it seems a better approximation of the real behaviour of mechanical structures. The buckling load of shells of any shape can be predicted. The method is now operational but a validation program is still in progress.

Validation is especially based on buckling of vessel heads under internal pressure. Available results are given for ellipsoidal or torispherical heads. When it is possible comparison is made with known experimental tests results. It is the case for KIRK and GILL tests, as we can see on the following table:

head	buckling pressure (atm.)	
	exp.results	comput. results
4 A	2.41	2.20
4 B	3.78	3.39
4 C	7.58	6.20

In order to get more experimental tests results, an experimental program has been launched in Saclay about head buckling under internal pressure.

1. The need for buckling analysis of LMFBR components

Unlike light water reactors, which operate at high pressures, Liquid Metal Fast Breeder Reactors operate at very low pressures. This is one of the advantages derived by the use of liquid sodium as a coolant. Hence it is possible to use thin materials for the primary circuit boundary. In the pool concept adopted in France for fast reactors, both for the Phénix (1) and Creys-Malville (2) power plants, the outer dimensions of the sodium vessel are large, but the thicknesses remain low. The weight of sodium used guarantees proper cooling of the fuel elements in case of failure of the flow pumps.

In order to picture the very thin thickness values in relation to the overall dimensions, it may be observed that the thickness of the cylindrical shell of the main vessel of Super Phénix is about 25 mm for a diameter of around 20 meters. This means that close attention must be paid to the risks of failure by buckling. This was effectively done throughout the development of the project. An especially interesting case was concerned with investigations of the torispherical end of the main vessel. This component is subjected to the internal sodium pressure and the dead weight of the core, which is applied to it by means of a shell (see Figures 1 and 2). These loads, and especially the pressure, are low, but may give rise to the appearance of folds in the toric zone of the end unless the shapes and dimensions are carefully selected. Note that the temperature of this end remains far below 300°C, and hence the creep effect is negligible. However, it emerged from the investigations that buckling could not occur before the appearance of plastic deformation. Consequently the buckling risk analysis had to account for stress distributions as well as changes in material behavior due to plasticity. Although other cases exist in which the risk of buckling must be considered, the vessel end is sufficiently typical so that the present study concentrates on the aspect of a torispherical end subjected to internal loads.

2. Validation and qualification of buckling modules in the CEASEMT system

The buckling risk analysis of the Super Phénix vessel (Creys-Malville power plant) was performed by means of the CEASEMT system of structural computation programs for finite elements (3, 4, 5, 6). Special use was made of the buckling analysis modules contained in the AQUAMODE and PASTEL (shells of revolution) and TRICO (shells of any shape) routines (27, 28, 29).

Regulatory constraints concerned with nuclear safety are especially severe in France, and are rigorously enforced by the responsible authorities. With respect to analyses of satisfactory component behavior, the builders and owners of power plants are of the opinion that the French regulations (7) are the most severe and restrictive to be encountered anywhere. For example, the ability of components to withstand damage, and the safety margin related to the various failure modes must be clearly proved (8, 9), and the simple application of a building code such as (18) is considered inadequate. These stringent principles are obviously applied to LMFBRs of which construction is planned in France.

Consequently, the use of a system of computer programs for mechanical structures is only approved if valid for the intended use (7). In the present case, a considerable effort has been made to validate the buckling computation methods. While the results obtained are already considerable, the work nevertheless goes on. The validation file to be compiled is in a way parallel to the different power plant safety reports.

This paper is intended to provide some indications concerning validation work, especially in relation to problems involving the main vessel end. The principle of validation work is clearly defined in (7) ; it must be demonstrated that the computation methods employed give results which are experimentally substantiated in a sufficient number of cases (comparable to the case of application to the reactor). At the present time, only the CEASEMT system features has a validation file which can be taken into consideration for safety analyses.

3. Buckling in the elastic region

The buckling of elastic bodies was investigated by Euler in the 18th century, and this gave rise to a fairly consistent theory which is elaborated in various works, some of which are classic (11). However, with respect to shells specifically (12), results did not always show agreement with experience. It was only fairly recently that Koiter resolved this problem by renovating the buckling theory (13, 14, 15).

In effect, when buckling is introduced into the structural analysis programs, by the method of finite elements, various points require special attention. In order to avoid encumbering this discussion, we shall set aside all matters which can be found in known publications (16, 17).

The first problem is the thorough knowledge of the expressions of the second order terms of matrix energy $K(\sigma)$. No complete formulation is available in the literature for most shell elements employed in finite element programs. The complete computation of these terms was accomplished for insertion into the CEASEMT system. In many cases, such as that relating to conical elements, the expressions obtained are long and complicated. The relative importance of the different terms does not emerge clearly. Hence the temptation is strong to discard all but the "most important terms". A complete study showed that while suitable results can be obtained by using simplified expressions in many cases, it is impossible to deal with all problems in this manner. Consequently, all second order terms are necessary, and have been retained in the formulation.

The second difficulty concerns the $K(P)$ matrices corresponding to the action of loads. In the case of non-conservative forces, in other words, those associated with the geometry of the structure (specially true of pressure), the $K(P)$ matrix depends on the loading parameters. Hence it includes non-linear terms which must be retained in the formulation, in order to obtain correct results.

Here again the necessary formulas are unavailable in the literature.

Many verification tests were performed on standard cases. Among these may be cited one of the tests relating to cylinders of revolution. This is a case in which buckling occurs in the absence of "compressive stresses", namely, where only tensile stress components exist. The tube considered is busjected to an internal pressure p , closed at the ends by leaktight plugs which slide to avoid the occurrence of axial tensions due to the end effect. In this case, the tube is subjected to a normal uniaxial circumferential stress (see Figure 3). It buckles under the action of internal pressure like an axially compressed column, and the buckling pressure is equal to that which creates, at the plugs, a force equal to Euler's critical load.

The CEASEMT system accurately computes the buckling pressure in such a case.

Returning to torispherical ends, computations were made of the critical internal buckling pressures of ellipsoids of revolution (18) and elliptical ends attached to shells of equivalent thickness (19). The results are closely comparable to those obtained by other methods (20). It is interesting to note that these results can be presented in a relatively simple form. The internal buckling pressure p_c may be written in the following manner :

$$p_c = p^* \frac{\pi^2 E}{1-\nu^2} \frac{t^2 b^2}{a^4}$$

where :

- . p_c internal buckling pressure
- . p^* (dimensionless)
- . E Young's modulus
- . ν Poisson coefficient
- . t thickness
- . b half-minor axis of the ellipse
- . a half-major axis of the ellipse.

It can be seen (Figure 4) that the coefficient p^* approaches 1 for $a/b > 2$ and that it tends towards infinity for $a/b = \sqrt{2}$.

4. Elastic plastic buckling

4.1 Investigatory problems

In practical cases, plastic deformation precedes the appearance of buckling. For torispherical ends, this phenomenon formed the the subject of a warning and a study by G.D. Galletly (21).

Plastic buckling, in other words, the instabilities which occur when the shell has already undergone plastic deformation, raises serious problems, even of precise definition.

This is an area in which the methods selected are subject to controversy, and in which the word paradox is frequently employed, to the extent that D. Bushnell gives the heading "The flow theory versus deformation theory paradox" to a section in one of his articles (22). The same point of view is found in

F. Masur's monograph (23).

A thorough review of the state of plastic buckling theories was made by J.W. Hutchinson (24). This work may be referred to if necessary. The demonstration suggested by Hill and Hutchinson of the main properties of plastic buckling (uniqueness, bifurcation), involves consideration, for each value of the loading parameter, of an elastic comparison solid with an elasticity matrix equal to the "matrix" associating the stresses with the deformation in the immediate vicinity of the elastoplastic case in question (in fact this "matrix" varies in form depending on whether plastification develops or not).

4.2 Computation procedure : choice of mathematical model

The process of formulation of the plastic buckling module is similar to this process. A two-step computation is carried out for every value of the loading parameter Λ .

- a plastic computation (not concerned with buckling) from which a plastic buckling matrix is derived corresponding to Λ or \bar{D}_Λ , as well as the stress field distribution,
- a computation of the critical load for a solid subjected to the above stresses, and of the properties given by \bar{D}_Λ , namely, such that the stress variation are associated with strain variations by :

$$\Delta \sigma = \bar{D}_\Lambda \Delta \epsilon$$

This defines (analysis in natural modes and natural values) the value of the ratio ω^2 of the corresponding critical load given by the parameter Λ_L to the parameter :

$$\omega^2 = \frac{\Lambda_L}{\Lambda}$$

This computation, carried out for increasing values of Λ , gives a curve :

$$\omega^2(\Lambda)$$

The value of the parameter Λ_C for which $\omega^2 = 1$ is that of instability (see Figure 5).

The computation chart for axisymmetrical shells is shown in Figure 6 .

In actual fact, the true problem is the definition of the \bar{D}_Λ matrix. Since this involves a technical analysis, it is wise to adopt a definition which accounts for geometric imperfections in a reasonably pessimistic manner, together with those of the material and especially for the possible existence of residual stresses.

The choice is difficult to make, but has been extensively discussed in the simple case of beams and columns. Let us simply note that the consideration of a reduced Young's modulus suggested at the turn of the century by Considère and resumed in 1910 by Von Karman was completely discredited in 1947 by Shanlay, who showed that it assumed a complete absence of defects. This explains why use of the tangent module leads to results approaching experimental results, which is not the case of the reduced modulus.

From these considerations, it may be concluded that the \bar{D}_Λ matrix used in the theory is inadequate. This is essentially because defects do exist, and because it is hardly justifiable to consider only the stability of the perfect

structure in the zone infinitely close to the state of equilibrium. Hence the choice is a matter of engineering practice, and the model selected here corresponds to the tangent module and is called "MOTAN", making it possible to account for the initial geometric imperfections in a pessimistic manner, as well as the residual stresses whose influence is considerable in practice.

4.3 Sample use : comparison

The first validation tests dealt with published experimental results. For torispherical ends, the most documented tests were those of (25). They were subjected to a complete computation published in (26). Given below are the main results for the three ends 4A, 4B and 4C investigated, and which consisted of an aluminium alloy.

Pressure in bars	4A	4B	4C
Experimental buckling pressure	2.41	3.78	7.58
Pressure computed by CEASEMT for plastic behavior	2.20	3.39	6.20
Pressure computed by CEASEMT for elastic behavior	10.27	11.12	12.66

It should be noted that the computed values are lower than those actually obtained. In view of the anisotropy of the material (the computation was performed for the lowest elastic limit) and of the very considerable influence of variations in thickness on buckling pressure, the result is highly satisfactory.

5. Validation program

As indicated above, the validation file is in the course of development.

For this purpose, a test program has been launched concerning buckling of elliptical ends under internal pressure. The "tests matrix" is shown in Figure 7. The results are not yet available, but Figure 8 shows the type of buckling obtained for one of these ends, and Figure 9 reproduces a recording of the deflection of the end axis as a function of pressure. The appearance of the various folds can be seen clearly in this recording. They are reflected by a pressure stagnation due to the volume increase caused by fold formation. In effect, as the flow rate of the feed pump is limited, the pressure drops slightly during the appearance of the fold.

Furthermore, an investigation of torispherical ends which short knuckle radius has been undertaken, in line with French Standard NF E 81.101. The representative end has the following dimensions :

- . mean diameter : D = 1000 mm
- . radius of spherical portion : R = 1200 mm
- . knuckle radius : r = 30 mm
- . height : h = 128.55 mm.

For a steel whose modulus of elasticity E = 200,000 MPa and whose yield stress Re = 200 MPa (without significant strain hardening), the following results are obtained.

Thickness (mm)	Computed critical pressure in bars	
	Plastic	Elastic
2	1.06	12.3
3	2.08	32.7
5	4.60	122.0
10	9.80	916.0
20	-	7900.0

6. Conclusions

The CEASEMT structural analysis system based on the method of finite elements features computation modules for buckling pressures in the elastic plastic region. Owing to its use in analyses of LMFBR vessels, it has been subjected to an extensive qualification program. This program is under way, but the results obtained, of which a portion relative to torispherical ends is given here, have succeeded in enabling its use.

References

- (1) Energie Nucléaire, Vol. 13, n° 3 (mai-juin 1971)
Nuclear Engineering International, Vol. 16, n° 182 (juillet 1971)
- (2) Saitcevsky B. et al, "Creys-Malville plant option and description", The European Nuclear Conference, Paris, April 1975, Vol. 20 of The Am. Nucl. Society Transactions
- (3) Hoffmann A. et al, "Plastic dynamic analysis of liquid metal cooled reactor components. Use of CEASEMT system", 3rd Int. Conf. on Struct. Mech. in React. Techn., London, September 1975, paper F4/4
- (4) Hoffmann A., Jeanpierre F. and Livolant M., "Système CEASEMT : Aperçus théoriques", Note CEA N-1934, CEN, Saclay (1976)
- (5) Jeanpierre F. et al, "Système CEASEMT : Ensemble des programmes de calculs des structures à usage industriel", Note CEA N-1938, CEN, Saclay (1976)
- (6) Jeanpierre F. et al, "CEASEMT system of finite elements computer programs : Use for inelastic analysis in liquid metal cooled reactor components", IAEA/IWGFR Specialists", Meeting, Champion, Pennsylvania (IAEA, Vienna) (April 1976)
- (7) "Appareils à pression de vapeur : Circuit primaire principal des chaudières nucléaires à eau", (Official Order and Circular of 26 February 1974), Journal Officiel de la République Française, No. 74-63 (Supplement to Booklet No. 1331)
- (8) De Torquat C. et al, "La sûreté des appareils à pression des chaudières nucléaires et son aspect réglementaire en France", in Principles and Standards of Reactor Safety, IAEA, Vienna (1973)
- (9) De Torquat C. and Roche R., "Nuclear pressure vessel analysis according to French regulations", 3rd Int. Conf. on Struct. Mech. in React. Techn., London, September (1975)

- (10) ASME, "Boiler and Pressure Vessel Code : Section III : Nuclear Components", ASME (1974)
- (11) Timoshenko S., "Théorie de la stabilité élastique", Béranger, Paris (1943)
- (12) Flügge W., "Stresses in shells", Springer, Berlin (1973)
- (13) Koiter W., "Elastic stability and post buckling behavior", Proc. Symp. Non-linear Problems, University of Wisconsin (1963)
- (14) Hutchinson J. and Koiter W., "Post buckling theory", Applied Mechanics Review, p.1353 and seq
- (15) Huseyin K., "Non-linear theory of elastic stability", Noordhoff Int. Pub. (1975)
- (16) Oden J.D., "Finite elements of non-linear continua", MacGraw Hill
- (17) Novozhilov, "Foundations of the non-linear theory of elasticity", Graylock Press, Rochester, NY (1953)
- (18) Solal R. et al, "Flambage élastique des ellipsoïdes de révolution", Note CEA N-1850, CEN, Saclay, February (1976)
- (19) Troclet B., "Flambage élastique des fonds elliptiques ajustés sur un cylindre", Note CEA N-1892, CEN, Saclay (1976)
- (20) Rotondo and Kraus H., "Buckling of an ellipsoid due to internal pressure", ASME paper 68 WA (PVP12)
- (21) Galletly G.D., "Internal pressure buckling of very thin torispherical shells : a comparison of experiment and theory", Paper G2/3, 3rd Int. Conf. on Struct. Mech. in Reac. Techn., London, September (1975)
- (22) Bushnell D., "Bifurcation buckling of shells of revolution", Int. J. of Solids Structures, Vol. 10, pp.1267-1305 (1974)
- (23) Masur E.F., "Buckling of shells : General introduction and review", ASCE Nat. Struct. Eng. Meeting, San Francisco, April (1973)
- (24) Hutchinson J.W., "Plastic buckling", Advance in Applied Mechanics, C. YIH Vol. 14, Academic Press (1974)
- (25) Kirk A. and Gill S., "The failure of torispherical ends of pressure vessels due to instability and plastic deformation : An experimental investigation", Int. Journ. of Mech. Scie., Vol. 17 (1975)
- (26) Troclet B., Hoffmann A. and Roche R.L., "Système CEASEMT : Validation des modules flambage plastique : Fonds en anse de panier : Comparaison avec les résultats expérimentaux de Kirk et Gill", Note CEA N-1893, CEN, Saclay (1976)
- (27) "CEASEMT system, AQUAMODE, User's Manual", Note CEA N-1929, CEN, Saclay (1976)
- (28) "CEASEMT system, PASTEL, User's Manual", Note CEA N-1932, CEN, Saclay (1976)
- (29) "CEASEMT system, TRICO, User's Manual", Note CEA N-1930, CEN, Saclay (1976)

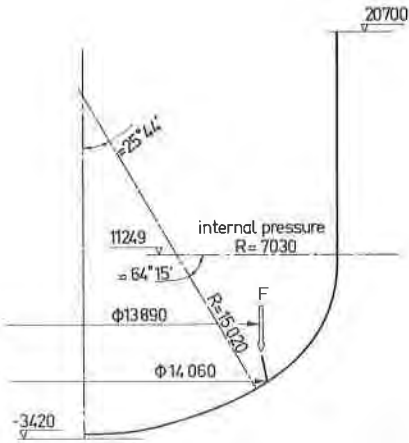

LMFBR Vessel
FIG 1

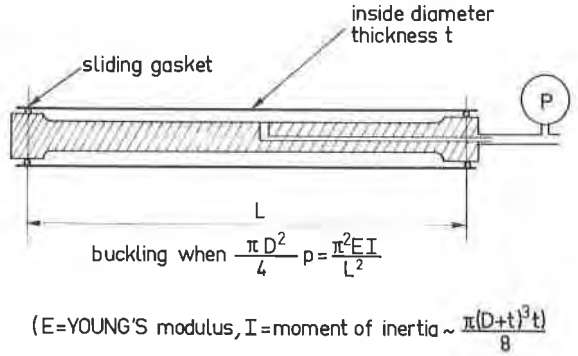

FIG 3

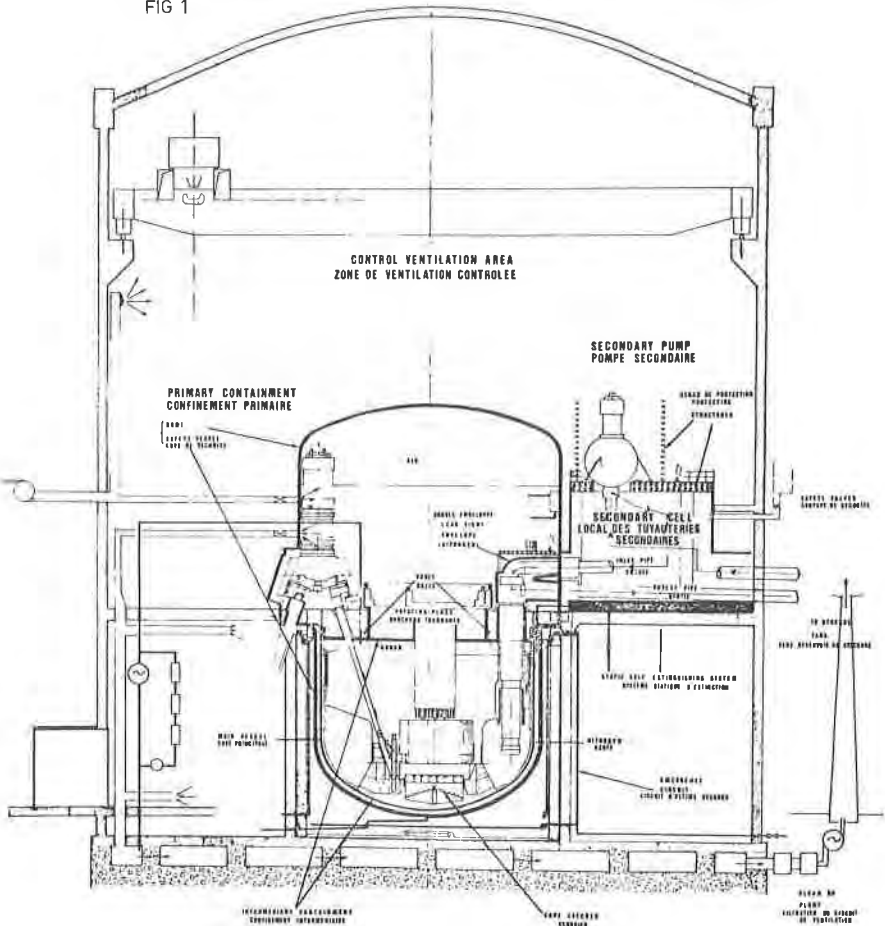
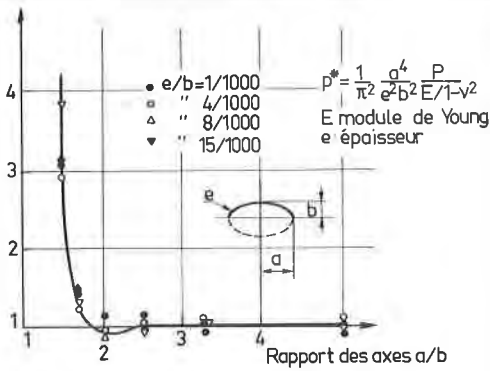

Fig. 2. — Le confinement de Super-Phenix.



BUCKLING OF ELLIPSOIDS

Fig 4

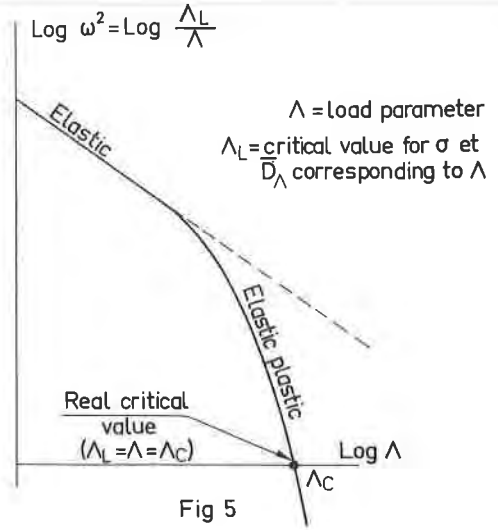

Fig 5

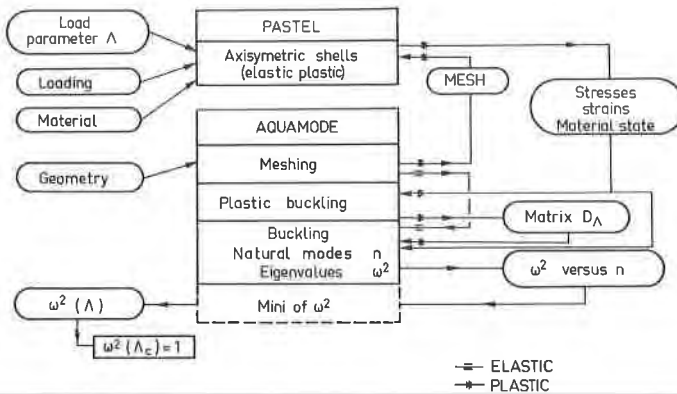

FIG 6 - ROUTINES FLOW SHEET

FIG.7

1000	_ Diameter mm
50 50 50 100 100 100	_ 1/2 small axis (mm)
2 1 05 2 1 05	_ thickness (mm)
X X X X X X	- Carbon steel
X X X X X X	- Austenitic steel
X X X X X X	- Aluminium-Magnesium



Fig 8

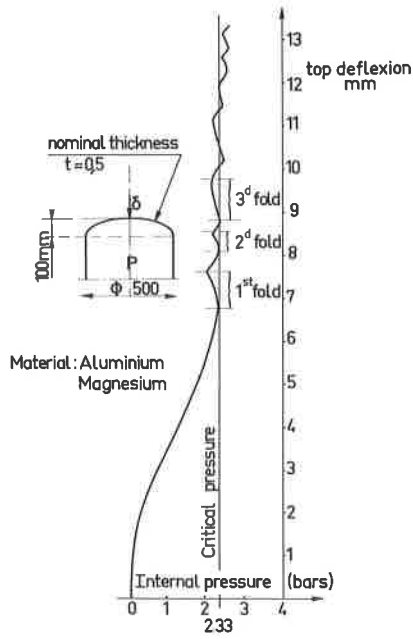

Fig 9