

Evaluation of Gap between Reactor Coolant System Piping and Pipe Whip Restraints

J.S. Yang ¹⁾, B.N. Kim ¹⁾, S.Y. Hong ¹⁾, K.W. Lee ²⁾ and D.H. Lee ³⁾

1) Nuclear Power Laboratory, Korea Electric Power Research Institute, KEPCO

2) Mechanical Dept., Kori Nuclear Power Division Unit 1&2, KEPCO

3) Mechanical System Engineering Dept., Korea Power Engineering Company

ABSTRACT

Interference between the crossover leg of the reactor coolant system (RCS) and the pipe whip restraints (PWR) has brought a degradation issue of the integrity of the Reactor Coolant system in Westinghouse type nuclear power plants (NPPs) of Korea. According to the gap inspection carried out during planned overhaul (Year 2000), interference between the crossover leg and the PWR was found in each RCS loop. This plant has had the high vibration problem on the RC pump 'B'. The reason for the high vibration in the RC pump 'B' has been massively surveyed and it was found that the crossover leg of the RCS contacted with the PWR in hot condition. Since the contact between the crossover leg and the PWR changes the dynamic characteristics of the piping system for the RCS, this is considered as one reason for the high vibration. And a possibility of overstress on the crossover leg due to the contact with the PWR should be evaluated. Through performing RCS integrity analyses, subsequent actions were initiated to increase the gap between those parts. As the results of the appropriate separation between two parts, it was reported that there was no unusual noise or vibration during plant heat ups. In this paper, the evaluations for the gap between the crossover leg and the PWR and the structural integrity due to loop binding is described.

INTRODUCTION

It was previously required that structures, systems, and components important to safety be appropriately protected against the dynamic effects of missiles, pipe whip, and discharging fluids that may result from a postulated pipe break. The primary equipment/piping supports are installed due to need for substantial protective measures to guard against the consequence of such postulated pipe breaks in accordance with this requirement ^[1]. The piping support system such as pipe whip restraints (PWR) may degrade the plant safety if the thermal expansion of the piping is restricted by the support system. The PWR is installed to limit piping displacement and to control pipe break opening areas in the event of postulated pipe break. In order to limit the piping displacement due to postulated pipe break and not to interfere with piping in normal operating conditions, a proper gap should be maintained at the piping/PWR interface. It is assumed that the shim plates were adjusted during the hot functional test such that the proper gap between the crossover leg and the PWR was maintained.

Recently, unexpected interference between the RCS piping and the PWR has brought a degradation issue for the integrity of piping and components of the RCS in the NPPs of Korea, which are the 15-20 years old nuclear power plants (2/3 loops, 650/950 Mwe, respectively) designed by Westinghouse. An abnormal vibration of the Reactor Coolant Pump (RCP), which is located at one side of the crossover leg piping, has been reported during start-up from the beginning of plant operation. Even though the massive surveys and the efforts to reduce the pump vibration were made by the plant engineering group with the oversea consultations, the frame vibration could not be reduced fundamentally. As one of the root causes, the field data measured by the plant engineering group showed a reliable evidence that the thermal movement of the crossover leg was

restricted by the individual PWR. Unanticipated restriction of thermal expansion for the crossover leg may result in support damage, high level of piping stresses and fatigue that were not considered in the original design of the system. Excessive stresses and fatigue can lead to functional impairment of piping and components. Also, the dynamic characteristics of the RCS may be changed by this loop binding between the crossover leg and the PWR. So, it is necessary to evaluate the integrity of the crossover leg due to the restriction of its thermal expansion because it has been operated in contacting with the PWR. Subsequently, the analyses for postulated pipe break to determine the proper gap between the crossover leg and the PWR should be performed. Based on this approach, the required actions to maintain the allowable gap between the crossover leg and the PWR were carried out during plant outage periods.

In this paper, evaluations for the gap between the crossover leg and PWR and for the integrity of the crossover leg due to the restriction of the thermal expansion were performed. As a result of the evaluations, the proper gaps between the crossover leg and the PWR were determined and it was confirmed that the structural integrity for the crossover leg and the PWR was maintained.

DESCRIPTION OF CROSSOVER LEG AND PWR

The crossover leg is a 31 in. I.D.(787.4mm) stainless steel pipe connecting the steam generator with the reactor coolant pump. The pipe material is SA-351 CF8A stainless steel. Two thrust blocks located at each elbow limit the displacement of the horizontal run of the crossover leg for the postulated pipe break. In the hot operating condition, the thrust block support structure is shimmed to nearly contact with the mating surface of the crossover leg over the whole area of a shim plate, and thus provides restraint to the crossover leg piping for all seismic and LOCA conditions. Excessive deflection of the vertical run of the crossover leg is prevented by the vertical drop restraint. Figure 1 illustrates a schematic diagram of the crossover leg and its support/restraints.

DATA RECORDING AND GENERAL OBSERVATIONS

In order to find the root cause for the abnormal vibration of RCP, the plant-engineering group initiated a program to closely monitor RCS component behavior during plant heat-up. The temperature and the displacements of the crossover leg were measured as the plant went through the heat-up and cool-down processes during the planned overhaul (Year 2000). Measurements were taken at eight locations over the shim plates, which were installed between the crossover leg and its support/restraint in the RCP side and the SG sides of the loop as shown in Figure 1. During the heat-up, measurements were taken about every 40 minutes to the hot stand-by condition by using the telescope and the filler gauge. The heat-up was halted at the selected plateaus to allow time for recording the data. As the heat-up proceeded, all of the crossover leg saddles (both SG and RCP sides) came into contact with their supports at approximately 270 to 275°C [518 to 527°F]. After reviewing the data obtained from this heat-up process, it was found that the root cause was the restriction of the thermal movement of the RCS piping caused by interference between the crossover legs and their support blocks.

STRUCTURAL INTEGRITY ASSESSMENT

As mentioned above, it was shown that the crossover legs at all loops contacted with the PWRs in hot condition. The stresses of the crossover leg resulting from the contact with the PWR in normal operating condition must be considered as additional stresses. These stresses are the secondary stresses resulting from restraining the thermal movement of the crossover leg. In case that there is no contact between two parts, the stresses were determined from the loads ^[2] based on the original design in accordance with ASME Section.III NB-3650, Service Level A & B Conditions ^[3]. Therefore, the additional thermal stresses were superimposed to obtain the total stress of the crossover leg resulting from the contact with the PWR in normal

operating conditions. This approach can be justified because the linear elastic behavior of the crossover leg was observed in gap inspection.

In order to evaluate the additional stresses resulting from the contact mentioned above, the thermal stress analysis of the crossover leg using the finite element method was performed. The entire crossover leg was modeled with the ANSYS computer program^[4] using straight pipe (PIPE 16) and curved pipe (PIPE 18) elements as shown in Figure 2. The amount of displacement restraining thermal expansion of the crossover leg were determined by linearly extrapolating temperature to the hot condition (292°C, 550°F) based on the temperature of the initial contact and the thermal expansion per unit temperature. The maximum value was evaluated as 1 mm, which is the amount of the thermal expansion of the crossover leg restricted by the PWR at RCP side. This value is the largest movement of the crossover legs during the heat-up. This was applied as input at the restrained point of the finite element analysis model. The boundary conditions in the analysis model were assumed to constrain the displacement and rotation of the RCP inlet nozzle and the SG outlet nozzle as shown in Figure 2. Subsequently, the stresses and the fatigue effects for the crossover leg due to restriction of the displacement presented herein were evaluated as per the ASME Sec. III NB-3650, 1974 Edition at the weld locations of the crossover leg as shown in Figure 3. As the results of the evaluation, the crossover leg satisfies the stress limits for Level A & B conditions of ASME Sec. III NB-3650 and the usage factors are negligible as shown in Table 1. Therefore, even though the crossover leg has been operated in contacting with the PWR, it can be concluded that there is no major impact on the structural integrity of the RCS crossover leg.

EVALUATION OF RESTRAINTS GAP

In order to determine the allowable gap between the crossover leg and the PWR, a gap to accommodate the protection criteria against dynamic effects resulting from rupture of the crossover leg^[1] should be selected. The locations and the types of postulated pipe failure for the crossover leg are summarized in Table 2 as shown in References[5,6]. The dynamic analytical model of the crossover leg was developed and the pipe break analysis of the crossover leg was performed with respect to the case of the postulate pipe ruptures listed in Table 2.

Firstly, the effects of the displacement and the break opening area resulting from the pipe rupture were reviewed to confirm whether the design requirements of the PWR were satisfied or not. It was assumed that the specified gaps (2 mm in SG side and 4 mm in RCP side) were maintained during hot condition. The nonlinear dynamic analysis for the broken crossover leg using a finite element method was performed. The broken crossover leg was modeled with the ANSYS computer code as shown in Figure 4. As the results of the analysis, it is judged that an impact to the neighboring equipment can not happen because the whipping motion of the broken crossover leg is much smaller than the distance of the neighboring equipment. The maximum displacements of the crossover leg after the pipe rupture are shown in Table 3. The maximum break flow area should be less than the full flow area at the location of the ruptured pipe as a design requirement. Results of the dynamic analysis show that the calculated circumferential break flow areas for the break locations are less than 50% of the full circular flow area of the crossover leg as shown in Table 4. Accordingly, the results mentioned above were indicated to meet the design requirements of the PWR.

Reactor coolant pipe restraints may be required to limit displacement or rotation of the reactor coolant pipe and thereby to reduce the nozzle load and also make the direction of the loading predictable. In addition to this requirement, the reactor coolant pipe restraints may be required to limit unrestricted displacement or rotation of the reactor coolant piping resulting from the formation of the plastic hinge mechanism. The plastic hinge formation for the several break locations as shown in Table 2 was reviewed to evaluate if the plastic hinge capacity is assured or not. The maximum moments for the plastic hinge as a design requirement were provided in Reference [5]. The moments of the crossover leg due to the blow-down loads resulting from postulated pipe failure were compared to the maximum design moments for the plastic hinge listed in Reference [5]. The results obtained from the nonlinear dynamic analyses are listed in Table 5 for comparison and showed less than the maximum design loads. Therefore, it was confirmed that the plastic hinge mechanism could not be formed from the blow-down loads resulting from postulated pipe failure.

In case that the crossover leg impacts the PWR, the latter should maintain its structural integrity under these impact loads. The stresses of the PWR at the locations mentioned above were determined and compared with ASME Sec. III Appendix F F-1331.1 Level D Service limits. The maximum stress intensity at each restraint was listed in Table 6 for comparison with the allowable stress intensities indicated in Reference [6]. Table 6 indicates that the maximum stress intensity is less than the allowable stress. So, it was ensured that the PWR could not collapse in the piping/restraints collision.

From the series of the analyses and the evaluation to determine the allowable gaps between the crossover leg and the PWR during normal operating conditions, the hot gaps between two parts (2 mm in SG side and 4 mm in RCP side) were determined. Also, the cold gaps based on the gap measurements during planned overhaul were determined.

CONCLUSION

In this paper, the evaluation for the abnormal stress condition of the crossover leg due to loop binding was presented, and it was confirmed that the structural integrity for the crossover leg was maintained even though the crossover leg had been operated in contacting with the PWR. However, in order to determine the allowable gap, the design requirements of the PWR were reviewed and the nonlinear dynamic analyses considering postulated pipe breaks were performed. Subsequently, the required actions to maintain the optimized gap between the crossover leg saddle block and the support block in normal operating conditions has been carried out for 2 outage periods. Those actions included the installation of the precisely re-machined shim plates in the support blocks. It was confirmed that the gaps between the crossover leg saddle block and the support block were maintained suitably during plant heat-up. Additionally, it was reported that there was no abnormal vibration of the Reactor Coolant Pump during subsequent plant heat-up.

REFERENCE

- [1] USNRC, Standard Review Plan 3.6.2, 1987, "Determination of Rupture Location and Dynamic Effects Associated with the Postulated Pipe Rupture of Piping".
- [2] WCAP-14974, Westinghouse Electric Corporation, Stress Distribution for Use in Flaw Evaluations for the Reactor Coolant Loop Piping Welds of Kori 1&2, Sep. 1997.
- [3] ASME Boiler and Pressure Vessel Code, Section III, Class 1 components, Division 1, Section NB, 1974 Edition.
- [4] ANSYS Computer Program, Users Manual, 2000, developed by ANSYS, Inc.
- [5] System Design Criteria for Kori 2, "Protection Criteria Against Dynamic Effects Resulting From Pipe Rupture".
- [6] NSSS Piping/Support Design and Analysis Interface Guidelines for Kori 2.

Table 1 Stress /fatigue results in weld locations of the crossover leg

	Weld location					
	1	2	3	4	5	6
Total Stress (MPa)	309.8	270.1	205.4	184.7	319.6	388.2
Allowable Stress (MPa)	409.5	409.5	409.5	409.5	409.5	409.5
Alternating Stress Intensity(MPa)	186.9	167.1	134.8	125.0	191.8	226.2
Usage Factor	0.0006	0.0004	0.0001	0.0004	0.0006	0.0015

Table 2 Postulated break location for the LOCA analysis of crossover leg

Location of postulated Rupture	Type	Break Opening Area
1. Steam Generator(SG) Outlet Nozzle	Guillotine	Cross-Sectional Flow Area of the Loop Pipe
2.Reactor Coolant Pump(RCP) Inlet Nozzle	Guillotine	Cross-Sectional Flow Area of the Loop Pipe
3. Loop Closure Weld in Crossover Leg	Guillotine	Cross-Sectional Flow Area of the Loop Pipe

**Table 3 Maximum displacements in each postulated pipe break case
(2 mm Gap in SG side, 4 mm Gap in RCP side)**

Break Case	Displacement with respect to each direction			PWR Design Requirement	
	Ux(mm)	Uy(mm)	Uz(mm)		
RCP Nozzle	8.74	-11.57	0.39	Satisfied	
SG Nozzle	68.02	-13.21	57.02	Satisfied	
Crossover Leg	RCP Side	7.83	-10.78	0.00	Satisfied
	SG Side	12.24	-31.06	1.06	Satisfied

**Table 4 Comparison of break flow area in each postulated pipe break case
(2 mm Gap in SG side, 4 mm Gap in RCP side)**

Break Case	Maximum Break Flow Area (mm ²)	Allowable Break Flow Area (mm ²)
RCP Nozzle	28064.5	243225.3
SG Nozzle	165160.9	243225.3
Crossover Leg	RCP side	26645.1
	SG side	59741.8

**Table 5 Comparison of plastic hinge moments in each postulated pipe break case
(2 mm SG Gap, 4 mm RCP Gap)**

Break Case		Maximum Moment (KN-m)	Allowable Moment (KN-m)
RCP Nozzle		4914.8	14529.8
SG Nozzle	Elbow	14258.7	14529.8
	Straight Run	11456.1	12665.6
Crossover Leg	RCP side	10100.8	14529.8
	SG side	5479.7	14529.8

**Table 6 Summary of stress intensities in each postulated pipe break case
(2 mm Gap in SG side, 4 mm Gap in RCP side)**

Break Cases	Restraint		Maximum Stress Intensity (MPa)	Allowable Stress Intensity (MPa)
RCP Nozzle	RCP Side Horizontal Run Restraint	Horizontal PWR	-	479.0
		Vertical PWR	261.9	
	SG Side Horizontal Run Restraint.	Horizontal PWR	-	
		Vertical PWR	-	
	Vertical Run Restraint		-	
SG Nozzle	RCP Side Horizontal Run Restraint	Horizontal PWR	31.3	479.0
		Vertical PWR	-	
	SG Side Horizontal Run Restraint	Horizontal PWR	-	
		Vertical PWR	142.7	
	Vertical Run Restraint		320.7	
Crossover Leg	RCP Side Horizontal Run Restraint	Horizontal PWR	77.7	479.0
		Vertical PWR	-	
	SG Side Horizontal Run Restraint	Horizontal PWR	192.3	
		Vertical PWR	27.6	
	Vertical Run Restraint		-	

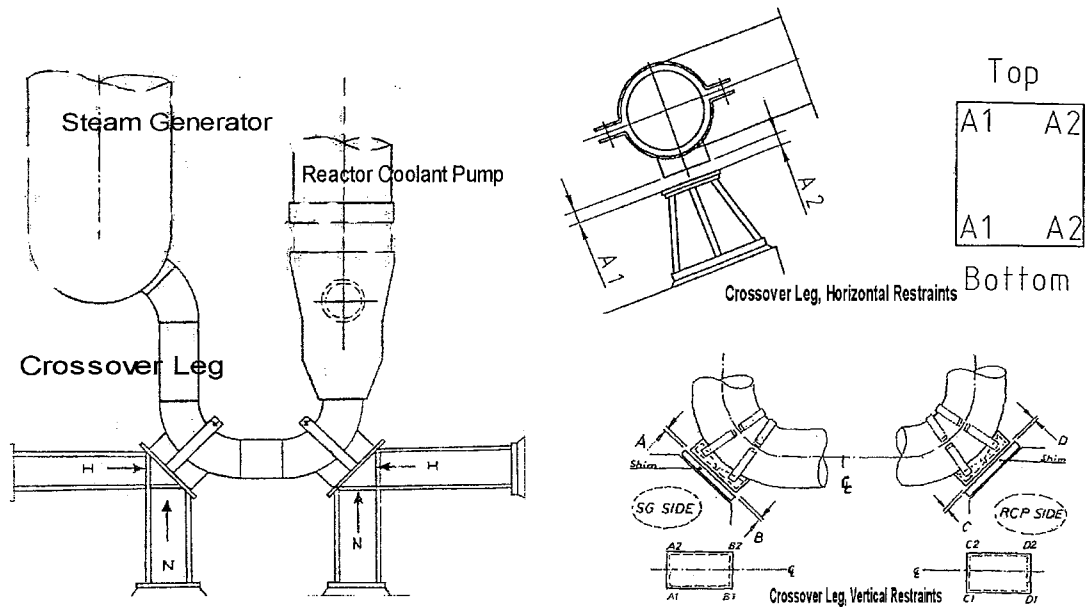

Figure 1. Schematic diagram of the crossover leg and support/restraints

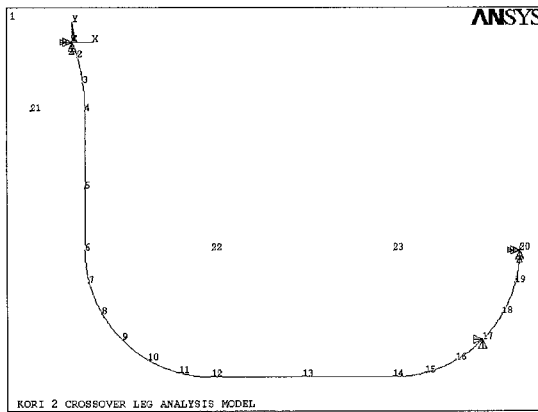

Figure 2. Static analysis model of the crossover leg

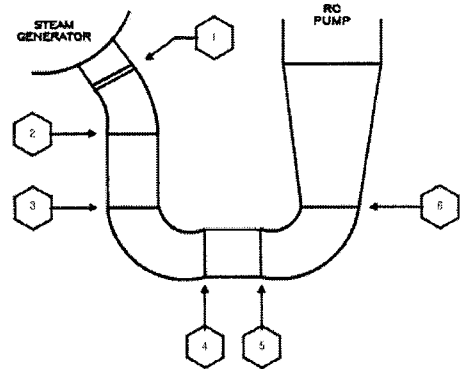

Figure 3. Weld location in crossover leg piping

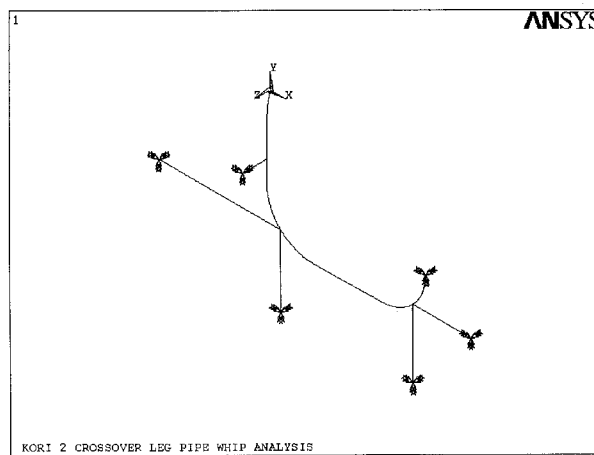

Figure 4. Dynamic analysis model of the crossover leg