



An Analytical Prediction on the Pump-Induced Pressure Pulsation in a Pressurized Water Reactor

Jong-sik Cheong, In-young Im, Seung-min Oh and Se-jin Baik

Korea Power Engineering Company, Inc., Korea

ABSTRACT

Pump-induced pressure pulsation in the reactor vessel annulus and inlet pipe of a pressurized water reactor is analyzed. Two systems of the inlet pipe and annulus are coupled, and a new intermediate boundary condition adopting impedance concept is imposed at the bottom of annulus. The pump forcings for each frequency are obtained using the measured pump discharge pressures. The open boundary condition at the bottom of annulus is found to be appropriate. An analytical solution for pressure distributions is obtained and found to be in good agreement with the measurements.

I. INTRODUCTION

Failures of reactor internals due to vibration in nuclear power plant have been reported, and a major cause has been presumed to be pump-induced acoustic pressure. To avoid this problem it is necessary to predict pump-induced acoustic pressure loadings on the structure. Due to the complexity of the geometry of reactor internals, however, the prediction of the pressure loads largely depends on the measured data from plant pre-operational tests.

Penzes[1] developed a solution method for the pressure distribution in the reactor annulus using a body force concept. In this method, the pressure distribution can be obtained only with the known pressure at the inlet nozzle, which makes the boundary condition to be non-homogeneous. Fisher et al.[2] developed a boundary operator method which set up a theoretical solution technique for equations with non-homogeneous boundary conditions. Au-Yang[3] performed an experimental and analytical investigation on the pressure in the annulus under the axially closed-closed condition. He used Green's function method for the analytical prediction, and the method revealed the circumferential zero mode effect which had been almost neglected by Penzes' calculation where an unreasonably big natural frequency had been obtained.

Application of all these methods to the reactor design analysis has some limitation due to the following reasons:

- 1) The forcing at the interface between the inlet pipe and annulus is not clearly defined.

2) The boundary condition at the bottom of annulus is not clearly defined.

When two systems are acoustically coupled, one system can act as a resonator or an anti-resonator to the other so that separate analyses for two systems do not describe actual phenomena. Cepkauskas[4] analyzed the pressure distribution in a pipe-annulus-coupled system. However, assuming the pressure at pump discharge known, he could not identify the pressure resonance condition, and his annulus model was not complete at that time. Lee and Chandra[5] proposed a piston-spring supported boundary condition. Should parameters be properly adjusted, the piston-spring supported boundary condition could be used for a so-called intermediate boundary condition, termed to describe a boundary condition being somewhere in between two extremes of “closed” and “open”. Lee et al.[6] applied this boundary condition to a pipe system having an interface with an annulus, but didn't extend it to the pipe-annulus-coupled system.

In this paper, two systems of the inlet pipe and annulus are coupled, and a new intermediate boundary condition adopting impedance concept is imposed at the bottom of annulus.

II. COUPLING OF TWO SYSTEMS CONNECTED

II.1 One-dimensional System

If two systems are connected, one system acts as a resonator or an anti-resonator to the other. In this section, two systems are coupled at the interface using the intermediate boundary condition and interfacial continuity condition. The governing equation and its boundary conditions for a system having a forcing at $x = 0$ and acoustically closed at $x = l$ are

$$\nabla^2 P - \frac{1}{C_0^2} \frac{\partial^2 P}{\partial t^2} = 0, \quad (1)$$

$$\varepsilon \frac{\partial P}{\partial x} \Big|_{x=0} = f_0 e^{j\omega_p t} \quad \text{and} \quad \frac{\partial P}{\partial x} \Big|_{x=l} = 0. \quad (2)$$

Then, the pressure distribution is expressed as

$$P(x, t) = \frac{f_0}{\varepsilon} \frac{1}{k} \frac{\cos k(l-x)}{\sin kl} e^{j\omega_p t}. \quad (3)$$

In order to define the interfacial continuity condition, the pipe at $x = x^*$ ($0 < x^* < l$) is divided into two regions as shown in Fig. 1. The pressure distribution at region I ($0 \leq x \leq x^*$) is obtained from Eq.(3) using the boundary condition as

$$\varepsilon \frac{\partial P}{\partial x} \Big|_{x=x^*} - j\xi^* \frac{\partial P}{\partial t} \Big|_{x=x^*} = 0, \quad (4)$$

where ξ is normally called as acoustic impedance. Then the pressure distribution in region I is

$$P_I(x) = \frac{f_0}{\varepsilon k} \frac{1 \sin k(x-x^*) - \Pi \cos k(x-x^*)}{\cos kx^* - \Pi \sin kx^*}, \quad (5)$$

where

$$\Pi = \frac{\varepsilon}{\xi^* C_0}.$$

The pressure distribution in region II ($x^* \leq x \leq l$) is

$$P_{II}(x) = \frac{f_I}{\varepsilon k} \frac{1 \cos k(l-x)}{\sin k(l-x^*)}. \quad (6)$$

From Eq.(5), forcing at $x = x^*$ becomes

$$f_I = \varepsilon \frac{dP_I}{dx} \Big|_{x=x^*} = \frac{f_0}{(\cos kx^* - \Pi \sin kx^*)}. \quad (7)$$

Since two regions are coupled, the pressure continuity condition at $x = x^*$ requires

$$\Pi \Big|_{x=x^*} = -\cot k(l-x^*). \quad (8)$$

Applying Eq.(8) to Eq.(5) or Eq.(6) leads to an identical expression as Eq.(3). In this case, even if x^* is chosen to have a resonance in Eq.(6), i.e., $\sin k(l-x^*) = 0$, Π becomes infinite and f_I goes to zero. Therefore, if two systems are coupled, separate analyses on each system do not produce any physically meaningful results for pressure distribution. It also shows that boundary condition in Eq.(4) is appropriate in defining the interfacial condition for a coupled system.

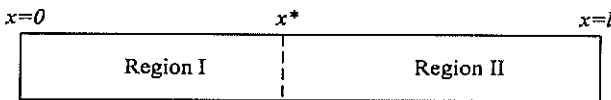

Fig. 1 One-dimensional Pipe

II.2 Pipe-Annulus System

Previous studies[1-5] also show that pressure distribution can be calculated for a one-

dimensional pipe or annulus if boundary conditions are well defined. However, for the pipe-annulus-coupled system, the interfacial condition cannot be defined by separate analyses for each region.

For a pipe-annulus-coupled system as shown in Fig. 2, if the forcing at the interface (f_i) is known, the annular pressure is expressed as [1]

$$P(r, \theta, z) = \sum_{m,n} \frac{f_i}{\epsilon} D_{mn} Z_n(z) \Theta_m(\theta) R_{mn}(r), \quad (9)$$

where $0 \leq z \leq L$, $0 \leq \theta \leq 2\pi$, and $0 \leq r \leq G$.

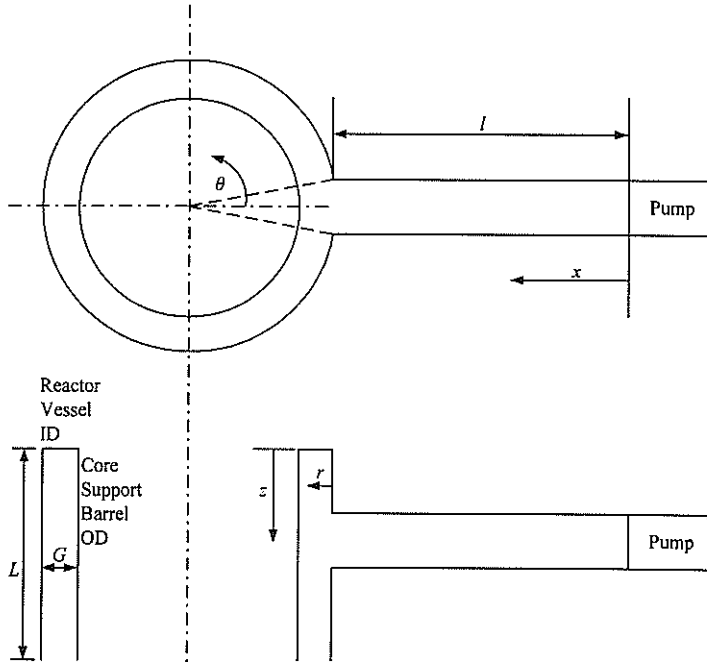

Fig. 2 Pipe-Annulus Coupled System for a PWR

If the gap (G) of the annulus is much smaller than the reactor vessel radius, the annulus can be assumed as a path between two plates so that $R_{mn}(r)$ is expressed as

$$R_{mn}(r) = \frac{\cos k_{mn}(r - G)}{k_{mn} \sin(k_{mn} G)}, \quad (10)$$

where

$$k_{mn}^2 = \left(\frac{\omega_p}{C_0}\right)^2 - \beta_n^2 - \left(\frac{m}{R}\right)^2.$$

At the outer surface of annulus ($r=0$), even though dR_{mn}/dr is not zero, the pressure derivative or the forcing becomes Heaviside function due to D_{mn} , and the boundary condition at the outer radius is satisfied. If the pipe-annulus interface impedance is assumed to be ξ , then the pressure in the pipe in Eq.(5) becomes

$$P(x) = \frac{f_0}{\varepsilon} \frac{1}{k} \frac{\sin k(x-l) - \Pi \cos k(x-l)}{\cos kl - \Pi \sin kl}. \quad (11)$$

By applying interfacial continuity condition, finally obtained are

$$\Pi = -\frac{k}{A} \sum_{mn} D_{mn} R_{mn}(r=0) F_{mn}, \quad (12)$$

where

$$F_{mn} = \int_A Z_n(z) \Theta_m(\theta) dA.$$

The pressure in the pipe-annulus system resonates only when

$$\Pi|_{res} = \cot kl. \quad (13)$$

III. BOUNDARY CONDITION FOR ANNULUS BOTTOM

Reactor coolant flows down the annulus to the reactor vessel lower plenum via the flow skirt, a cylindrical perforated plate controlling flow distribution in the lower plenum. With this geometry, it is difficult to decide whether it has open boundary condition or closed at the annulus bottom. Impedance expression of Eq.(4) is appropriate for defining this intermediate boundary condition.

The axial boundary conditions of the reactor annulus are of closed type at the top and intermediate type at the bottom with impedance ξ_L . The axial mode is expressed as $Z_n = \cos \beta_n z$, and β_n can be obtained from

$$(\beta_n L) \tan(\beta_n L) = L \omega_p \xi_L. \quad (14)$$

This expression is interpreted as:

- (1) The system has a closed boundary condition if $\xi_L = 0$.
- (2) The system has an open boundary condition if $\xi_L = \infty$.

Fortunately, there are orthogonality relations as

$$\int_0^L Z_n Z_m dz = 0, \quad m \neq n \quad (15a)$$

and
$$\int_0^L Z_n^2 dz = \frac{1}{2} \left[L + \frac{\xi_L \omega_p}{\beta_n^2} Z_n^2(\beta_n L) \right], \quad m = n . \quad (15b)$$

Therefore, the impedance expression of boundary condition is applicable to not only open or closed boundary but also intermediate boundary.

IV. COMPARISON WITH FIELD DATA

A Comprehensive Vibration Assessment Program (CVAP) was performed for Palo Verde Nuclear Generating Station Unit 1 (PVNGS 1) in the United States in 1983. During the measurements at 50 inches downstream of pump discharge nozzle, highest pressures were measured at 240Hz, the second harmonic frequency of pump blade passing frequency, as shown in Table 1[7], which was unexpected and could not be explained by previous studies[1-6].

Geometrical data of PVNGS 1 are presented in Table 2. There are two unknown parameters: 1) pump forcing, and 2) boundary condition at the annulus bottom. The pump forcing is expected to be dependent on the system temperature and forcing frequency as expressed as

$$f_0(\omega_p, t, T) = c(T) \sum_i f_0(\omega_{pi}) * \cos(\omega_{pi} t), \quad (16)$$

where $c(T)$ is a temperature dependent adjustment factor.

Since the measured pressures are dependent on the geometry of the loop, they are not directly converted to the pump forcings. To examine the general trend of pump forcing with the frequency and its dependency on the temperature, the concept of "relative" pump forcing is introduced which is defined as the ratio of pump forcing of each frequency to that of 240Hz. Even for the same measured pump discharge pressures, various sets of relative pump forcings can be obtained by the system pressure response equations depending on the boundary condition at the bottom of annulus. Until finding a specific case that the trend of relative pump forcings with frequency is similar to that of the measured pressures for all conditions, all cases with different boundary conditions are been investigated. It is found that the boundary condition at the bottom of annulus needs to be of nearly open type; i.e., $\xi_L = \infty$.

Using this boundary condition, a set of relative pump forcings are obtained as shown in Fig.3, where the relative pump forcing is considered independent of temperature.

Also shown in Fig.3 are the "representative" relative pump forcings for each frequency, for which two peculiar data points of 360°F have been discarded; one from Set 1 at 480 Hz, and one from Set 2 at 120 Hz. Using the representative values, the pump discharge pressures

are calculated as presented in Table 3, where it is assumed that $c(T) = 0.055\varepsilon$. The result shows that the pump discharge pressures at 240Hz are in most cases greater than that at 120Hz, which is in good agreement with the measured data.

Using the relationship between the pump forcing and the pressure response, the pump-induced pressure pulsation distributions in the reactor annulus are obtained as shown in Figs. 4-(a) and 4-(b), respectively for the axial and circumferential distributions.

Table 1 Measured Pump Discharge Pressure at PVNGS 1, psi

Forcing Frequency Hz	360°F		550°F		565°F	
	Set 1	Set 2	Set 1	Set 2	Set 1	Set 2
120	0.16	0.31	0.19	0.29	0.16	0.22
240	2.90	2.90	0.49	0.55	0.49	0.44
360	0.05	0.16	0.10	0.08	0.06	0.08
480	0.10	0.33	0.29	0.35	0.25	0.35
600	0.05	0.07	0.05	0.04	0.06	0.04

Table 2 Geometrical Data of Reactor Annulus and Cold Leg Piping of PVNGS 1

Length of Inlet Piping	290 in.
Length of Annulus	373 in.
Diameter of Inlet Nozzle	30 in.
Location of Inlet Nozzle from Top of Annulus	140 in.
I.D and O.D of Annulus	162/182 in.

Table 3 Calculated Pump Discharge Pressure, psi

Forcing Frequency Hz	Temperature, °F		
	360	550	565
120	0.05	0.58	0.41
240	2.74	0.91	0.39
360	0.07	0.19	0.08
480	0.35	0.54	0.25
600	0.10	0.09	0.03

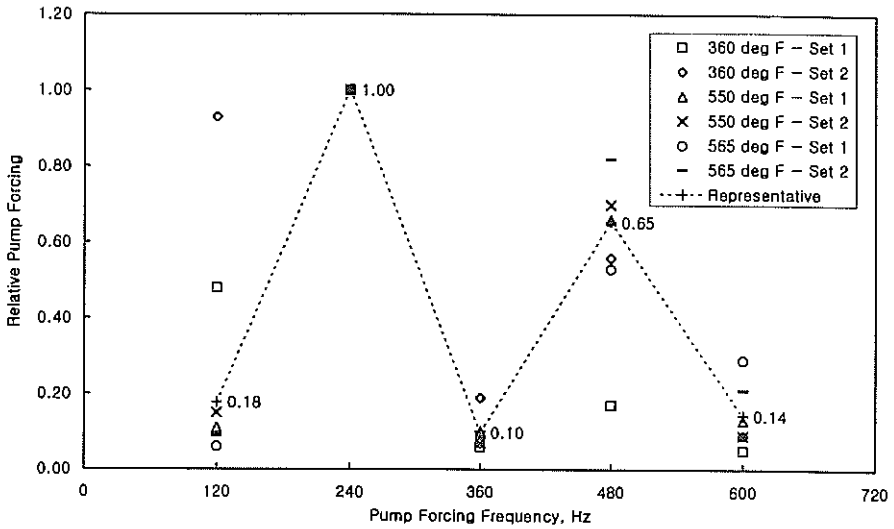

Fig. 3 Relative Pump Forcings with Representative Values for Respective Frequencies

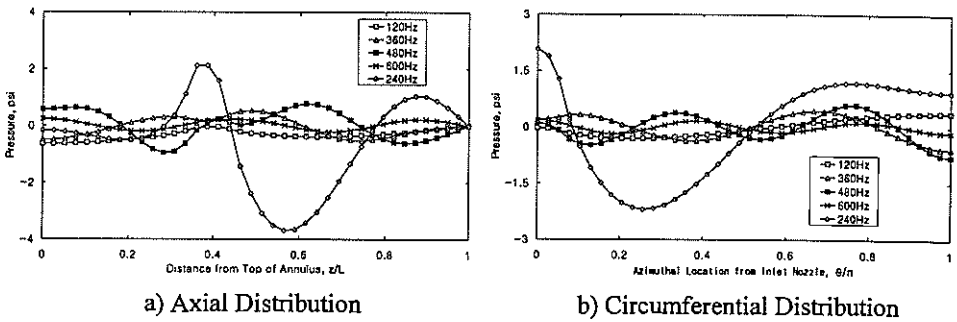

Fig. 4 Pressure Distribution in Reactor Vessel Annulus at 360°F

V. CONCLUSION

The relationship between pump forcing and pressure response is established by coupling two systems of the annulus and inlet pipe, and by applying intermediate boundary condition based on impedance concept at the bottom of annulus. The representative relative pump forcings for each frequency are obtained using the measured pump discharge pressures at PVNGS 1, and open boundary condition at the bottom of annulus is found to be

appropriate.

An analytical solution for pressure distributions in a pipe-annulus-coupled system is obtained by the proposed approach, and is in good agreement with the measurements. This analytical method can eventually be used for the design purpose if it is confirmed through the benchmark against more measured data.

Nomenclature

A	interface area
C_0	sonic velocity
D_{mn}	Fourier coefficients for expansion of Heaviside function which is 1 at interface and 0 elsewhere, with Z_n and Θ_m
f_0, f_1^*, f_l	forcing at $x = 0$ (pump discharge location), $x = l^*$, and $x = l$ (end of pipe), respectively
k	wave number, $k = \omega_p / C_0$
l	length of inlet pipe
L	length of annulus
R_{mn}	radial mode
Z_n	axial mode, $Z_n = \cos \beta_n z$, β_n : determined from axial boundary condition
ϵ	proportional parameter
Θ_m	circumferential mode, $\Theta_m = \cos m\theta$, $m = 0, 1, 2, 3, \dots$ for annulus
ω_p	forcing frequency

References

1. L. E. PENZES, "Theory of Pump Induced Pulsating Coolant Pressure in Pressurized Water Reactor," *Nuc. Eng. & Design*, Vol. 27, 1974, pp. 176-188
2. H. D. FISHER, M. M. CEPKAUSKAS and S. CHANDRA, "Solution of Time Dependent Boundary Value Problems by the Boundary Operator Method," *Int. J. Solids Structures*, Vol. 15, 1979, pp. 607-614
3. M. K. AU-YANG, "Pump-Induced Acoustic Pressure Distribution in an Annular Cavity Bounded by Rigid Walls," *J. of Sound and Vibration*, Vol. 62(4), 1979, pp. 577-591

4. M. M. CEPKAUSKAS, "Acoustic Pressure Pulsations in Pressurized Water Reactors," 5th SMIRT (1979)
5. L. LEE and S. CHANDRA, "Pump Induced Fluctuating Pressure in a Reactor Coolant Pipe," *Int. J. Press. Ves. & Piping*, Vol. 8, 1980, pp. 407-417
6. K. B. LEE , I. Y. IM and S. K. Lee, "Analytical Prediction on the Pump-Induced Pulsating Pressure in a Reactor Coolant Pipe," *Int. J. Press. Ves. & Piping*, Vol. 52, 1992, pp. 417-425
7. D. E. SHARRARD and P. F. JOFFRE, "Interpretation of Pressure Pulsation Data of PVNGS 1 Demonstration Test," *ABB-CE Interoffice Correspondence*, V-TH-156, August 1984