

## ABSTRACT

BROWN, JENNIFER AMBER. Cheese Texture. (Under the direction of Dr. E. Allen Foegeding.)

Cheese is a popular food due to its diversity in application, nutritional value, convenience, and good taste. Producing high quality cheeses that meet consumer expectations is crucial in order for cheese makers to remain competitive. These expectations include proper end-use functionality (shred, melt, stretch, etc.) and appropriate texture. Currently, there is not a complete understanding of what characteristics govern these aspects. This study seeks to determine what transitions occur during the early stages of maturation of certain cheeses, specifically, how the changes in physicochemical properties in young cheeses affect textural changes perceived when consumed.

Mozzarella and Pizza cheeses were tested at 4, 10, 17, and 38 d of age; Process cheese was tested at 4 d of age. Rheological methods were employed to determine the linear, non-linear, and fracture properties of the cheeses. A trained sensory panel developed appropriate descriptive language and product-specific reference scales to evaluate cheese texture. Both sensorial and rheological methods differentiated the cheese varieties, and patterns were observed as the cheese aged. Rheological analysis showed the cheeses were viscoelastic gels with greater storage ( $G'$ , elastic) than loss ( $G''$ , viscous) moduli. The overall magnitude of  $G'$  decreased as the cheeses aged; creep recovery analysis confirmed the loss of overall firmness with time. Five sensory terms differentiated the ages of the cheeses within varieties. Correlations between the sensory and rheological methods were observed.

Principal component analysis revealed that combinations of both sensory and rheological parameters could distinguish the cheeses based upon variety and age.

Comparison of certain large strain rheological methods was also done. Fracture stresses and fracture strains (or apparent strain) at three different strain rates (0.0047, 0.047, and  $0.47 \text{ s}^{-1}$ ) were determined using both torsion and vane methods to see how the large strain properties compared in these cheeses. Overall, vane fracture stresses were lower than torsion fracture stresses. As the strain rate increased, the fracture stresses increased. Simple linear regression of the torsion and vane fracture stresses revealed that the torsion fracture stresses were 2.0 times higher than the vane fracture stresses ( $R^2=0.66$ ).

Mozzarella is an anisotropic material since the body of this cheese has fibers that are oriented in a specific way. Methodology to appropriately evaluate the sensory perception of such materials was explored. No differences in any of the sensory terms were found between samples tested having the fibers oriented parallel to the force applied and samples tested having fibers perpendicular to the force applied.

Finally, the thermal behavior of these cheeses was considered through use of differential scanning calorimetry. Two different heating schemes were used to determine if glass transitions occur in these cheeses and to characterize melting behavior. Glass transition temperatures were determined in the Process cheese. The heating profiles at elevated temperatures (i.e. during melting) were similar in all cheeses at all ages. It is likely that the transitions observed during melting are due to phase changes in certain lipids within the cheese.

These results have significant implications in the cheese industry. An understanding of the transitions in both physical and chemical properties in young cheeses can help to

explain what causes change in the perceptual texture, which may help in producing customized cheeses. Future testing should focus on how such parameters affect end-use functionality in order develop similar models which will help cheese makers to meet consumer demands.

**CHEESE TEXTURE**

by

**JENNIFER AMBER BROWN**

A thesis submitted to the Graduate Faculty of  
North Carolina State University  
In partial fulfillment of the  
Requirements for the Degree of  
Master of Science

**DEPARTMENT OF FOOD SCIENCE**

Raleigh

2002

**APPROVED BY:**

---

E. Allen Foegeding, Ph. D.  
Chair of Advisory Committee

---

Christopher R. Daubert, Ph. D.

---

Mary Anne Drake, Ph. D.

---

Marcia Gumpertz, Ph. D.

## **BIOGRAPHY**

Jennifer Amber Brown was born on December 28, 1977 in Nevada, Missouri. She is the daughter of Marsha and Larry Forkner. She was raised on a farm in Southwest Missouri with her sister, Jill. Among her activities in high school, the author especially enjoyed participating in church youth group, playing on the volleyball team, being in the band and jazz band, doing service projects, and traveling with family. She graduated from Nevada High School in Nevada, Missouri in the spring of 1996 and began her undergraduate studies at the University of Missouri- Columbia that fall. As an undergraduate, she was involved in Kappa Alpha Theta sorority, College of Agriculture, Food, and Natural Resources (CAFNR) Student Council, CAFNR Ambassadors, CAFNR Alumni Board, Food Science Club, and was a director for Ag Week. She completed internships with the Missouri Pork Producers, the Missouri Cattlemen's Association, and the Quaker Oats Company. She also worked at the University of Missouri in the CAFNR Career Services Office. She graduated Magna Cum Laude in 2000 with a Bachelor of Science degree in Food Science and Human Nutrition and was honored as the "Outstanding Senior" in the College of Agriculture, Food, and Natural Resources. Following graduation, Jennifer interned at General Mills in the Sensory and Betty Crocker Dessert divisions. She began pursuing her Masters of Science in Food Science in August of 2000 under the direction of E. Allen Foegeding. She married Charles Brown, of Huntsville, Missouri, on October 21, 2000 in Nevada, Missouri. Together they enjoy hiking, traveling, cooking, and helping with various youth activities at their church.

## ACKNOWLEDGMENTS

I would like to first thank Dr. Hildegard Heymann, Dr. Robert Marshall, Dr. Ingoff Gruen, and Dana Brown at the University of Missouri for encouraging me to challenge myself and to pursue my goals.

I would like thank Dr. E. Allen Foegeding for inviting me to work with such a vibrant lab group on such a dynamic project. You helped me to further develop my reasoning skills, allowed me to make decisions independently, and modeled how to balance both career and personal life. Thank you also for giving me the opportunity to see the joys of teaching!

I would also like to acknowledge my graduate committee. Thank you to Dr. Christopher Daubert for always being available to answer questions and to ask the challenging ones. Thank you to Dr. Mary Anne Drake for giving me hands-on experience and for training me on so many levels in sensory analysis. Finally, thank you to Dr. Marcia Gumpertz for your willingness to provide help both in and out of the classroom.

Thank you to my family, especially my parents, Larry and Marsha Forkner and my sister, Jill. I am so blessed to have such a loving family. Thank you for encouraging me in so many ways and for teaching me to take the right paths, even though they are not always the easiest ones. To my husband, Chuck... words cannot express how grateful I am to have you in my life. You continually lift me up and love me unconditionally. Thank you for your friendship, provision, accountability, and laughter. Finally, I acknowledge Jesus Christ, in whom I have strength to do all things.

## TABLE OF CONTENTS

	<b>Page</b>
LIST OF TABLES .....	viii
LIST OF FIGURES .....	x
REVIEW OF LITERATURE .....	1
Introduction .....	2
Texture Definition .....	2
Texture Generation in Cheese .....	3
Milk constituents and preparation .....	3
Cheese-making process .....	5
Cheese ripening and maturation .....	8
Assessment of Texture .....	12
Assessment of physical properties .....	12
Perceptual texture assessment .....	24
Relating physical and perceptual texture .....	28
Conclusions .....	32
References .....	34
CHANGES IN RHEOLOGICAL PROPERTIES OF YOUNG CHEESES DURING MATURATION .....	43
Abstract .....	44
Introduction .....	45
Materials and Methods .....	48
Material description .....	48
Rheological analysis .....	49
Statistical analysis .....	53
Results and Discussion .....	53
Viscoelastic properties .....	53
Relaxation properties .....	57
Non-linear and fracture properties .....	58

Relationships among rheological properties .....	60
Conclusions .....	62
Acknowledgments .....	62
References .....	64
CHEESE TEXTURE CHARACTERIZATION .....	81
Abstract .....	82
Introduction .....	83
Materials and Methods .....	88
Material description .....	88
Rheological analysis .....	89
Sensory analysis .....	93
Statistical analysis .....	94
Results and Discussion .....	95
Rheological characterization .....	95
Differentiation by sensory means .....	96
Correlation analysis .....	96
Principal component analysis .....	98
Conclusions .....	102
Acknowledgments .....	103
References .....	104
COMPARISON OF TORSION AND VANE RHEOLOGICAL METHODS TO EVALUATE YOUNG CHEESE TEXTURE .....	120
Abstract .....	121
Introduction .....	122
Materials and Methods .....	126
Material description .....	126
Methods .....	126
Results and Discussion .....	129



Sample observations .....	129
Fracture parameters .....	129
Comparison of vane and torsion fracture stress .....	130
Conclusions .....	130
Acknowledgments .....	130
References .....	131
THE EFFECT OF FIBER ORIENTATION OF YOUNG MOZZARELLA CHEESES ON THE SENSORY PERCEPTION OF TEXTURE .....	140
Abstract .....	141
Introduction .....	141
Materials and Methods .....	142
Material description .....	142
Sensory analysis .....	143
Statistical analysis .....	144
Results and Discussion .....	144
Conclusions .....	145
Acknowledgments .....	145
References .....	146
CHARACTERIZATION OF YOUNG CHEESES USING DIFFERENTIAL SCANNING CALORIMETRY .....	149
Abstract .....	150
Introduction .....	150
Materials and Methods .....	151
Material description .....	151
Differential scanning calorimetry .....	151
Results and Discussion .....	152
Glass transition .....	152
Melting behavior .....	152

Conclusions .....	153
Acknowledgments .....	154
References .....	155

## LIST OF TABLES

	<b>Page</b>
<b>CHANGES IN RHEOLOGICAL PROPERTIES OF YOUNG CHEESES DURING MATURATION</b>	
Table 1- Definitions of instrumental parameters used for statistical analysis.....	78
Table 2- Correlation analysis of instrumental parameters .....	79
Table 3- Eigenvector loadings for principal component analysis of instrumental parameters .....	80
<b>CHEESE TEXTURE CHARACTERIZATION</b>	
Table 1- Language, evaluation, and references used to qualify and quantify cheese texture perception .....	114
Table 2- Means table of significant terms to differentiate ages of cheeses ..	115
Table 3- Correlation analysis of sensory terms .....	116
Table 4- Correlation analysis of sensory and instrumental terms .....	117
Table 5- Eigenvector loadings for principal component analysis of sensory attributes .....	118
Table 6- Eigenvector loadings for principal component analysis of sensory and instrumental parameters .....	119
<b>THE EFFECT OF FIBER ORIENTATION OF YOUNG MOZZARELLA CHEESES ON THE SENSORY PERCEPTION OF TEXTURE</b>	
Table 1- Language, evaluation techniques, and references to qualify and quantify cheese texture perception .....	148
<b>CHARACTERIZATION OF YOUNG CHEESES USING DIFFERENTIAL SCANNING CALORIMETRY</b>	
Table 1- Onset temperature, glass transition temperature, and enthalpy changes for maturing cheeses .....	156

Table 2- Onset temperature, melting temperature, and enthalpy changes for maturing cheeses .....	157
--	-----

## LIST OF FIGURES

	<b>Page</b>
<b>CHANGES IN RHEOLOGICAL PROPERTIES OF YOUNG CHEESES DURING MATURATION</b>	
Figure 1- Capstan geometry for torsional testing .....	69
Figure 2- Effects of aging on storage ( $G'$ ) and loss ( $G''$ ) moduli over changing frequencies for Mozzarella, Pizza, and Process cheeses..	70
Figure 3- Effects of aging on phase angle ( $\delta$ ) over changing frequencies for Mozzarella, Pizza, and Process cheeses .....	71
Figure 4- Effects of aging on creep recovery behavior for Mozzarella, Pizza, and Process cheeses .....	72
Figure 5- Burgers model of creep recovery response .....	73
Figure 6- Effects of aging on fracture behavior at three speeds in Mozzarella, Pizza, and Process cheeses .....	74
Figure 7- Effects of aging on linear, non-linear, and fracture stresses and strains for Mozzarella and Pizza cheeses at two strain rates .....	75
Figure 8- Principal component analysis of instrumental data (principal component one versus principal component two) .....	76
Figure 9- Principal component analysis of instrumental data (principal component one versus principal component three) .....	77
<b>CHEESE TEXTURE CHARACTERIZATION</b>	
Figure 1- Capstan geometry for torsional testing .....	109
Figure 2- Principal component analysis of sensory data (principal component one versus principal component two) .....	110
Figure 3- Principal component analysis of sensory data (principal component one versus principal component three) .....	111
Figure 4- Principal component analysis of sensory and instrumental data (principal component one versus principal component two) .....	112

Figure 5- Principal component analysis of sensory and instrumental data (principal component one versus principal component three) .....	113
---	-----

COMPARISON OF TORSION AND VANE RHEOLOGICAL METHODS  
TO EVALUATE YOUNG CHEESE TEXTURE

Figure 1- Capstan geometry for torsional testing .....	134
Figure 2- Geometry for four blade vane analysis .....	135
Figure 3- Pictorial representation of fiber orientation in Mozzarella samples during torsion analysis .....	136
Figure 4- Modified texture map .....	137
Figure 5- Vane and torsion texture maps for maturing cheeses at three speeds .....	138
Figure 6- Linear regression of vane fracture stress and torsion fracture stress .....	139

THE EFFECT OF FIBER ORIENTATION OF YOUNG MOZZARELLA  
CHEESES ON THE SENSORY PERCEPTION OF TEXTURE

Figure 1- Pictorial representation of sensory evaluation method for determining fiber orientation effects .....	147
--	-----

# **REVIEW OF LITERATURE**

**J. A. Brown**

Department of Food Science  
North Carolina State University

## **INTRODUCTION**

In many countries, cheese is a staple in the human diet. Cheese-making has historically been a way to preserve the most desirable components of milk (Adda et al., 1982). It is considered an ideal food due to its high nutrition, convenience, variety, availability, and good taste (Bogue et al., 1999). With its widespread popularity and production, the consumers' palate is becoming more discriminating when determining cheese purchases. Now, more than ever, producing high quality cheeses that meet the consumers' expectations is crucial in order for cheese makers to remain competitive.

One such consumer expectation is that the selected cheese possesses an anticipated texture, characteristic of that particular cheese variety. Texture is an important characteristic used to differentiate many cheese varieties. Wendin et al. (2000) discovered that texture attributes were more important in describing differences between cream cheese samples than the taste and flavor attributes. Antoniou et al. (2000) grouped and distinguished French cheeses based upon instrumental and sensory measurements of texture.

Additionally, appropriate cheese texture is considered by the consumer to be a determinant of overall quality. Textural characteristics are a determinant of consumer preference in cheese (Lee et al., 1978; Adda et al., 1982; McEwan et al., 1989). Conversely, when the perceived texture of the food during mastication does not match the visible or descriptive expectation, consumer preference and acceptability will be low (Guinard and Mazzucchelli, 1996).

## **TEXTURE DEFINITION**

Szczesniak (1963) reviewed many definitions of texture. All definitions reviewed



described two fundamental principles: texture pertains to the actual, physical structure of the material, and texture is a perception of the visual and tactile elements of the material.

Christensen (1984) noted that both of these properties (physical and perceptual) are derived from the basic elements of the food structure and the sensory systems, implying that understanding fundamental information about both the physical structure of the material and the human sensory processes utilized during mastication is necessary in order to draw conclusions about a material's texture. Therefore, to fully define a food's texture, one must measure both the physical properties and the perceptual properties of the food.

### **TEXTURE GENERATION IN CHEESE**

In order to be able to fully understand what determines cheese quality and texture, it is necessary to have an understanding of the physical and chemical mechanisms that occur during cheese processing. Generally, the components and processing techniques are basically the same for all cheeses, but the proportions of these components vary.

#### **Milk constituents and preparation**

Milk is composed of water, proteins (primarily casein), lipid, lactose, and minerals. The goal when making cheese is to form a network from the casein that entraps the fat and some of the water and concentrate this by removing excess whey. The first stage in the processing of cheese is milk standardization. Milk standardization gives the producer the ability to manipulate the composition of the final cheese by controlling the composition of the starting milk in order to meet the legal definition of the specific variety and to improve yields. There are several ways in which milk is standardized (Lucey and Kelly, 1994). First, the fat content of the milk can be altered. This is done in order to meet legal standards for fat

in the dry matter and for labeling considerations. Typically, fat content is increased by adding cream or decreased by adding skim milk. Second, protein content can be altered. The casein content of the original milk ultimately determines the amount of cheese that can be produced since caseins form the structural matrix and can retain moisture (Scott, 1998). Protein content is usually increased by either adding nonfat dry milk or evaporated condensed milk.

Other considerations of the initial milk that affect cheese yield include the source of the milk and whether or not the milk is homogenized. Milk coming from mastitic cows has higher somatic cell counts, indicating an increase in plasmin activity. Plasmins degrade  $\beta$ -caseins, (Fox, 1989) which initially results in less network formation and lower yields. Also, the breed of cow and time of lactation influences the composition of the milk (Lucey and Kelly, 1994). Homogenization is the process in which fat globules in the milk are broken up into smaller pieces. Use of homogenized milk for cheese-making will produce higher yields since more moisture will ultimately be retained in the protein network. However, such milk produces a finer network of protein, which impairs curd-matting properties and results in cheese with decreased end-use functionality such as stretch and melt (Rowney et al., 1999).

Additionally, the use of ultrafiltration to concentrate the milk has adverse effects on texture and rate of maturation. Ultrafiltered (UF) milk affects the composition, structure, and maturation of cheese, which then affects the texture. In a study comparing cheese milk, cheese curds, and final cheese at five weeks and twenty-four weeks of UF milk cheese and control milk cheeses, it was found that the protein network became coarser throughout the entire processing scheme as the concentration factor of the milk increased. They also found that larger pockets of fat in the curds resulted in greater concentrated milks throughout the

entire processing scheme (Green et al., 1981). From a sensory perspective, firmness, crumbliness, granularity, and dryness increased as the concentration factor of the milk increased. Elasticity was affected little by the concentration. Since structurally, the UF and the control milk were similar, they hypothesized that structural differences seen between the curds of each were probably due to differences in the concentration of milk components rather than the structural differences in the initial milk. They hypothesized that the basic structure of the protein network is established during the initial curd formation and is not altered much during later stages of ripening.

### **Cheese-making process**

*Alterations in the microbial flora.* After the milk is standardized, it is pasteurized in order to destroy harmful microorganisms and to inactivate enzyme networks. Once it is pasteurized, a cocktail of starter cultures is added. These serve three purposes. First, the starter cultures digest the lactose in the milk and produce lactic acid, which aids in lowering the pH of the milk creating the ideal environment for coagulation. The pH affects the reactivity of the binding sites on the casein molecules and therefore, influences the structure of the matrix (Rowney et al., 1999). Second, the browning characteristics of the final cheese are determined by how the starter cultures process the lactose. Lactose is a sugar composed of one molecule of galactose and one molecule of glucose. For example, *Lactobacillus delbrueckii* only digests glucose, leaving some residual galactose, which will brown due to Maillard browning when the final cheese is heated. Third, starter cultures produce enzymes that affect cheese flavor and texture.

*Structure formation via coagulation.* The next step in making cheese is coagulation in which rennet is added to the milk. Coagulation has been described as a two-phase process.

In the first phase, para-caseins are formed by enzymatic reactions. Chymosin, an enzyme in rennet, acts upon the casein micelle in the milk to form the para-caseins (Richardson, 1992). Chymosin cleaves off the  $\kappa$ -casein between the Phe<sub>105</sub>-Met<sub>106</sub> bond, releasing glycomacropeptide into solution; this makes the micelle less sterically and electrostatically stable (Fox, 1989; Dalgleish, 1992; Dalgleish, 1997). The bare micelle is now composed of primarily  $\alpha$ ,  $\beta$ , and para  $\kappa$ -caseins. When approximately 85% of the  $\kappa$ -casein has been hydrolyzed, the second phase of coagulation begins (Fox, 1989). The para-caseins start to aggregate. Phosphoserine groups, contained in the casein, react with the calcium in the cheese to form bridges, connecting the caseins (Swaisgood, 1992). Over time, many connections form a three-dimensional network of casein; this network entraps fat and moisture, forming a multicomponent gel.

The structure of cheese fits a filled gel model. A filled gel is described as a multicomponent material in which one of the components is a gelling agent that forms a continuous network and the other component(s) acts to fill in the network (Tolstoguzov and Braudo, 1983). Cheese is composed of a continuous, three-dimensional network of primarily casein. When this protein network forms during coagulation, it entraps fat globules and moisture contained in the milk forming the filler component (Prentice, 1987). It is thought that since the fat is highly hydrophobic, water in this system can associate with the protein; it exists in both free and bound states (Prentice, 1972).

***Post-coagulation procedures.*** After the curd has coagulated, it is cut into smaller, cube-shaped pieces in order to expel excess moisture and whey from the protein network. When fresh curd is cut, the curd particles are easily deformed, improving syneresis. The curd particles can then fuse together after expelling some water due to the protein in the curd (van

Vliet and Walstra, 1983). It is crucial that the firmness of the coagulant be optimal before cutting. If the curd is too weak when cut, the network will shatter and fat will be lost, decreasing yields and altering texture; if the curd is too firm when cut, the protein network will break and there will be high loss of casein, again, altering texture. After cutting, the curds are left alone for a short period of time known as a healing period. During the healing period, a "skin" forms on the outside of the curd, which prevents further losses of fat and moisture. The curds are then stirred and cooked in order to expel moisture and to promote shrinkage of the protein network.

After cooking, whey is drained from the curds. The pH of the whey determines the proportions of chymosin and plasmin retained in the cheese (Fox, 1989). Both of these have the capability to cause breakdown of the protein network during storage, which greatly impacts the final texture of the cheese.

A number of steps may now occur depending upon the variety of cheese being made. For example, curds are salted and matted together in a process known as cheddaring when making Cheddar cheese. This process makes the protein network more dense, resulting in a characteristic texture. In Mozzarella cheese, the curds are immersed into hot water, which acts as a plasticizer. The curds are stretched and kneaded, causing the protein network to have a specific orientation; this also, results in the characteristic fibrous texture. When Mozzarella is torn, as is typical in the consumption of "string cheese", the orientated protein matrix breaks, and the water and fat in the matrix is expelled (Taneya et al., 1992).

It is at this point that the altered curds are typically pressed into molds. If the curds are not salted, the molds may be soaked in brine. Salt influences textural changes as the cheeses age. Such changes are most apparent in brined cheeses, where immediately

following molding, cheeses are immersed in a sodium chloride solution. Osmotic pressure differences exist between the cheese and the brine, causing the sodium chloride to migrate into the block; simultaneously, in order to maintain equilibrium osmotic pressure, moisture from the cheese block exits into the brine (Guinee and Fox, 1987).

### **Cheese ripening and maturation**

The cheese is now ready to be stored. Typically, as they age, a decrease in firmness (or softening) of the cheese body occurs. The degradation of the protein matrix is thought to cause this change since the lipid phase is discontinuous and would, therefore, not contribute as much to the overall consistency of the body (de Jong, 1976). Two phases of texture development during storage have been identified. Phase one occurs within the first seven to fourteen days after production. During this time, the rubbery texture of the young cheese is converted into the more smooth characteristic texture of the specific variety. It is believed that during this phase, proteolysis of the casein network is taking place. Hydrolysis by residual coagulant of about 20% of the  $\alpha_{s1}$ -casein, which produces the  $\alpha_{s1}$ -I peptide, causes a weakening of the casein network (de Jong, 1976; Lawrence et al., 1987); specifically the Phe<sub>23</sub>-Phe<sub>24</sub> or Phe<sub>24</sub>-Val<sub>25</sub> bonds are most susceptible to hydrolysis by residual enzyme (Fox, 1989). The  $\alpha_{s1}$ -I peptide is present in all cheeses during the early stages of ripening. A more gradual change in cheese texture occurs during phase two of ripening. It is during this time period that the rest of the  $\alpha_{s1}$ -casein and the other caseins are hydrolyzed. Unlike phase one, which takes only days, phase two occurs over a period of months (Lawrence et al., 1987). However, it has been shown that the  $\beta$ -casein does not change as much during ripening as  $\alpha_{s1}$ -casein (de Jong, 1976; Creamer and Olson, 1982).

It should be noted that in very old cheeses, some varieties (i.e. Cheddar) show highly

brittle texture. Several factors could explain such a change. First, as the cheeses age, evaporation of available water on the surface occurs, causing a “drier”, more fragile cheese. Second, as proteolysis occurs, more and more “new” ionic peptides are created; as each “new” group is created, competition for available water increases. Less water is available to solvate the protein chains, and the resulting cheese is harder and less deformable (Creamer and Olson, 1982).

***Effects of proteolysis.*** Changes in the texture of cheese can be related to the rate at which proteolysis occurs; these reactions are affected by many things. First, though most coagulant is lost in the whey when drained, some is retained in the curd. If no active coagulant is present in the curd, then no  $\alpha_{s1}$ -casein degradation can occur, and therefore, cheese softening will not happen (i.e. the cheese will maintain the young, rubbery texture) (Lawrence et al., 1987). The amount of residual coagulant depends upon the pH of the system. Lower curd pH at draining encourages retention of more rennet resulting in increased hydrolysis of  $\alpha_{s1}$ -casein. Second, the pH at drain determines the amount of plasmin in the curd. Plasmin is a native milk proteinase that is responsible for much of casein breakdown. Plasmins are associated with the casein micelle in fresh milk, but as the pH decreases, they dissociate from the caseins. Third, the salt to moisture ratio affects the amount of intact casein; at lower ratios, there is less intact casein than at higher ratios. As discussed earlier, the salt to moisture ratio in the molded cheese also controls the activity of the residual rennet and plasmin in the cheese. Fourth, the storage temperature (or ripening temperature) impacts the rate of proteolysis, though the impact on textural characteristics depends upon the type of protein being proteolyzed. It is believed that  $\alpha_{s1}$ -casein hydrolysis contributes more structurally to the cheese than the other caseins. At temperatures below 6°

C, the amount of  $\beta$ -casein hydrolyzed decreases significantly, but the amount of  $\alpha_{s1}$ -casein hydrolyzed only slightly decreases. Therefore, cheeses of the same variety ripened at different temperatures below  $6^{\circ}\text{C}$  are not very different texturally. However, ripening temperatures above  $10^{\circ}\text{C}$  have significant effects on creating textural differences since more  $\alpha_{s1}$ -casein is hydrolyzed as the temperature is increased. Cheese proteolysis is negatively correlated with firmness, indicating softening of the cheese as the protein matrix is broken down. Fifth, changes in pH during storage affect the rate of proteolysis. Generally, the rate of breakdown of  $\alpha_{s1}$ -casein is greater at lower storage pH than the rate of breakdown of  $\beta$ -casein. Finally, both dissolved calcium in the cheese serum and calcium bound to the protein network have been shown to affect the rate of proteolysis. However, it is difficult to distinguish the direct effect of calcium since the total amount of calcium retained in the curd is determined by the point at which the whey is drained from the curd. Simultaneously, the drain point also controls the amount of residual rennet and plasmin in the curd, both of which are factors determining cheese texture (Lawrence et al., 1987).

***Effects of pH.*** Texture of cheese is also dependent upon the pH of the finished cheese, which affects the state of the protein aggregates. Cheeses having a low pH (near the isoelectric point of casein) show a granular texture and shatter when deformed; higher pH cheeses are more plastic and elastic. At low pH, strong ionic and hydrophobic intra-aggregate forces hold the casein aggregates in a compact formation (inter-aggregate forces are weaker). Water in this system is less mobile. At higher pH, casein molecules have a net negative charge. Though the hydrophobic interactions still exist, the ionic interactions change to a repulsive nature. The tight protein aggregates absorb water to solvate the non-neutral ionic charges. This effect can be minimized depending upon the extent of ionic



calcium bound to the casein in the cheese, which decreases the solubility of the protein (Creamer and Olson, 1982). Additionally, the mineral equilibrium within the cheese influences the texture. Calcium acts to cement the casein micelles together. During maturation, calcium is transported from the center to the outside of the cheese causing the core to have a lower calcium content (Adda et al., 1982).

***Effects of brine migration.*** Brine-immersed cheeses show dramatic changes in texture during the early stages of aging. Brine migration patterns and rates have been modeled (Geurts et al., 1974; Geurts et al., 1980); the pseudo diffusion coefficient of sodium chloride through the moisture in Gouda cheese was estimated to be a rate of  $0.2\text{-cm}^2\text{ day}^{-1}$ . Sodium chloride affects both the matrix and the serum phases of the cheese, which, in turn, affects the overall texture. It has been determined that sodium chloride in the serum phase of Mozzarella cheese promotes the microstructural swelling of the para-casein matrix resulting in an increased water-holding capacity and formation of a hydrated gel. Simultaneously, the sodium chloride promotes the solubilization of intact caseins from the para-casein matrix; it is hypothesized that these proteins are able to freely migrate between the matrix and the serum phase (Guo and Kindstedt, 1995; Guo et al., 1997). The calcium phosphate bridges that connect the bare casein micelles in the protein matrix are affected in a process called demineralization. The sodium ions are able to displace the calcium ions in the calcium phosphate bridge. This allows for water in the system to be able to bind to the complex, either increasing the water holding capacity of the matrix, or promoting the protein to become soluble in the serum (Geurts et al., 1972). Additionally, salt changes the appearance of cheeses making them less opaque. As was discussed, salt increases absorption of serum into the matrix making a more homogeneous matrix. This results in fewer discontinuities

(surfaces) to cause light to scatter, making the cheese appear more translucent (Paulson et al., 1998).

***Effects of composition.*** Cheese composition also affects final texture. Cheeses having a higher fat content are less firm and more elastic; the recently popular low fat cheeses are firmer and less smooth due to the increase in the amount of protein matrix (and lack of lipid filler). Likewise, the level of protein directly affects the firmness of the cheese; the more protein the cheese has initially, the firmer the cheese is. It has also been shown that small variations in water content greatly affect firmness; water content is affected by cheese-making conditions and by surface evaporation during ripening (Adda et al., 1982).

## ASSESSMENT OF TEXTURE

As described earlier, texture pertains to the actual, physical structure of the material, and texture is a perception of the visual and tactile elements of the material. Because both the physical realm and the perceptual realm pertain to texture description, two classes of measurements must be done in order to completely understand cheese texture.

### **Assessment of Physical Properties**

***Definitions.*** To measure the physical properties of materials, rheological methods are employed. Rheology is the study of the deformation and flow of materials (Steffe, 1996). Such methods measure the mechanical properties of the materials under various conditions, namely at various stresses and strains. Stress ( $\sigma$ ) relates to the forces applied to materials and is calculated by the following relationship:

$$\sigma = \frac{F}{A}$$

where  $F$  is force (Newtons) and  $A$  is area ( $m^2$ ). Stresses can be tensile, compressive, or shear. Strain ( $\epsilon$ ) is the amount of deformation in a sample and is dimensionless:

$$\epsilon = \frac{\Delta L}{L_o}$$

where  $\Delta L/L_o$  is defined as a change in the geometry of the material. Rheological measurements of the mechanical properties give an indication of the chemical and structural nature of the material.

Perfectly fluid materials obey Newton's Postulate:

$$\sigma = \mu \dot{\gamma}$$

where  $\mu$  is the Newtonian viscosity and  $\dot{\gamma}$  is the strain rate. This linear relationship between stress and strain rate infers that the viscosity of the fluid will not change with changes in strain rate; the material is considered to be ideal. In modeling, the viscous element is represented by a dashpot. Ideally solid materials obey Hooke's law:

$$\sigma = G\gamma$$

where  $\sigma$  is the shear stress and  $\gamma$  is the shear strain. These materials do not flow and are considered to be perfectly elastic. Such materials are represented by a spring. Very few foods are either perfectly viscous or perfectly elastic; most materials contain both of these elements and therefore, are referred to as viscoelastic. Cheese is a viscoelastic material in that it exhibits both solid-like and fluid-like behavior (van Vliet and Walstra, 1983; Konstance and Holsinger, 1992; Taneya et al., 1992).

There are three categories of rheological tests: empirical, imitative, and fundamental tests (Tunick, 2000). Empirical tests supply basic, single-point information, and the parameters for such tests are usually guided by previous experience. An example of such a

test would be a cheese-maker lifting curd from the vat using a spatula in order to check for the proper consistency before cutting. Imitative tests try to imitate the forces and deformations associated with a specific process. Instrumental Texture Profile Analysis (TPA) fits into this category, as the goal of this test is to imitate the process of biting through a sample. Fundamental tests give information as to the elemental properties of a material. They include some fracture testing, dynamic rheological testing, and transient rheological testing.

*Small strain methods.* Small strain rheological methods are used to define both the elastic and the viscous nature of cheese. Such methods are implemented within the linear viscoelastic region of the material and therefore, are designed to be non-destructive to the basic structure of the material (van Vliet and Walstra, 1983; Gunasekaran and Ak, 2000). Additionally, by performing such tests within the linear viscoelastic region, the elastic and loss moduli become only a function of time and not a function of the magnitude of the stress or strain applied (Tunick, 2000). Cheese is a time-dependent material in that the response of the cheese to an applied stress depends upon the speed in which the stress is applied making such methods appropriate. For example, when biting into a piece of cheese, the amount of time that the stress is applied is relatively short and the elastic response is prominent. Conversely, when stress is applied over a long time period, as in eye formation in Swiss-type cheeses, the reaction of the viscous component dominates (van Vliet and Walstra, 1983).

Dynamic rheological test methods are used to determine the elastic and viscous components of viscoelastic materials. Additionally, dynamic methods allow for an understanding of short-range interactions such as conformation and structure of the casein particles. Such tests vary either the stress or strain harmonically with time in an oscillatory

type movement. In dynamic tests, the strain function is (Steffe, 1996):

$$\gamma = \gamma_o \sin(\omega t)$$

where  $\gamma_o$  is the maximum amplitude of the strain,  $\omega$  is the frequency (rad), and  $t$  is the time (sec). The stress function in dynamic tests is:

$$\sigma = \sigma_o \sin(\omega t - \delta)$$

where  $\sigma_o$  is the amplitude of the shear stress,  $\omega$  is the frequency (rad),  $t$  is the time (sec), and  $\delta$  is the phase angle (degree). The complex modulus ( $G^*$ ) relates shear stress to shear strain:

$$G^* = \frac{\sigma}{\gamma}$$

Phase angle ( $\delta$ ) is a measurement of the difference between the input strain/stress and the response of the material; it shows the degree to which the input and response sinusoidal curves are in or out of phase. For example, in a purely viscous material, when a stress or strain is applied, the fluid's response is very delayed. The input and response curves are completely out of phase, and  $\delta$  is  $90^\circ$ . When a stress or strain is applied to a perfectly elastic material, the material instantly responds in a linear fashion; the input and response curves are perfectly in-phase and therefore,  $\delta$  is  $0^\circ$ .

Specifically, phase angle is a ratio of the energy lost to the energy stored:

$$\tan(\delta) = \frac{G''}{G'}$$

where  $G''$  is the loss modulus and  $G'$  is the storage modulus. The loss modulus ( $G''$ ) characterizes the viscous component of the material and is defined as:

$$G'' = G^* \sin \delta$$

The loss modulus ( $G''$ ) defines the amount of energy dissipated (Steffe, 1996); in cheese,

the viscous component is related to flow of the filler through the network or the existence of “dangling ends” (Konstance and Holsinger, 1992). The storage modulus ( $G'$ ) defines the elastic element of the material and is calculated by:

$$G' = G * \cos \delta$$

The storage modulus ( $G'$ ) defines the amount of energy stored by the material (Steffe, 1996); the elastic component of cheese is an indication of the elasticity of the protein network and filler components (Prentice, 1987).

Physical gels are defined as materials that are made of chains that are non-covalently crosslinked into networks; these can be classified as either strong or weak based upon their small strain behavior. Both strong physical gels and weak physical gels behave as solids at very small deformations ( $G' > G''$ ). However, at larger deformations, strong physical gels behave as solids, whereas the viscous component is more dominant in weak physical gels; weak gels are defined as being structured fluids (Ross-Murphy, 1995). The maximum linear strain for strong physical gels is  $\gamma_{lin} \sim 0.2$ , whereas weak physical gels show a maximum linear strain up to 1000 times less (Kavanagh and Ross-Murphy, 1998).

Results from small strain studies provide a way to characterize and differentiate cheese varieties. Nolan et al. (1989) used dynamic, small strain rheological methods to differentiate natural and imitation Mozzarella cheese. They found that measurements of the viscous and elastic components of the cheeses were very sensitive to calcium citrate concentration. Additionally, this group observed that specimen slippage in the instrument was occurring possibly due to the migration of milk fat onto the surface of the cheese at room temperature. They concluded that the use of cryanoacrylate glue to bond the cheese samples to the rheometer plate surfaces was most appropriate. Even cheeses that are difficult to

differentiate using other analytical techniques can be easily classified using small strain methods. By measuring the viscoelastic properties of Cheddar and Cheshire cheeses, Tunick et al. (1990) showed that small strain methods are more appropriate to distinguish these cheeses than methods that show differences in protein content, specific heat values, and microstructural properties.

Results from viscoelastic characterization also impact cheese formulation practices. Ma et al. (1996) compared viscoelastic properties of reduced-fat and full-fat Cheddar cheese, specifically observing how lecithin incorporation affected viscoelasticity on reduced-fat cheese. They observed that the full-fat cheese had a greater elastic ( $G'$ ) and loss ( $G''$ ) modulus over the same stress region as the reduced fat samples. Lecithin addition increased the elastic modulus of the reduced fat samples, but did not change the loss modulus. They speculated that the addition of lecithin to the reduced-fat cheese changed the three dimensional structure of the cheese since the elastic modulus increased with the lecithin addition, but the loss modulus did not change.

Small strain methods are especially useful in understanding mechanisms of some end-use functions. Guinee et al. (2000) wanted to understand the mechanism of the melting process in order to be able to develop cheeses with predictable melting characteristics. They observed the microstructure of three different commercial cheeses using confocal scanning laser microscopy and then looked at how the viscoelasticity of these same cheeses changed as the cheeses were heated. As expected, the phase angle ( $\delta$ ) increased as the cheeses were heated indicating that the cheeses were becoming more viscous and less elastic. The group was also able to differentiate analogue cheeses from natural cheeses based upon their different melting patterns. They hypothesized that the analogue Pizza cheese was more heat

stable than the natural cheeses due to its having an emulsified fat phase, a more continuous protein phase, and some starch present in the network. Using the small strain rheological data and the microscopy data, they hypothesized that the softening of the cheese due to the application of heat was probably due in part to the liquefaction of the fat phase and coalescence of this liquefied fat.

Finally, small strain rheological characterization can be used to determine changes caused by processing and storage parameters of cheeses. Rosenberg et al. (1995) observed the effects of pasteurization of milk and storage time on Cheddar cheese structure using a controlled-stress rheometer. They found that in cheeses made from pasteurized milk,  $G'$  and  $G''$  decreased as the Cheddar aged due to breakdown of the protein network from residual coagulant. However, the opposite trend was observed in Cheddar made with raw milk. Although analysis of the raw milk cheeses showed that the extent of proteolysis was greater in the older cheese, a separate analysis of the types of peptides in each cheese showed that the raw and pasteurized milk cheeses had different peptide profiles. This could account for the differences seen in the viscoelastic properties of these cheeses. Subramanian and Gunasekaran (1997a) investigated changes in the linear viscoelastic region (LVR) of Mozzarella cheese due to changes in storage time and temperature. They found that the strain limit decreased with increasing temperature and age; they hypothesized that this was due to proteolysis and thermal softening over time, which would result in decreased viscosity and elasticity of the material. Extending their previous work, Subramanian and Gunasekaran (1997b) looked at the dynamic viscoelastic properties of Mozzarella cheese. They found that the elastic component contributed more to the overall viscoelastic nature of the cheese. Additionally, their results showed that both the storage and loss modulus decreased with



storage time, again due to proteolysis that occurs. A loss of network integrity and a decrease in the size of dispersed particles happens because degradation products of casein are water-soluble and cannot contribute to the protein network causing the viscosity and elasticity to decrease.

***Large strain methods.*** In addition to small strain rheological methods, large strain methods are also used to determine cheese texture; large strain measurements occur outside of the linear viscoelastic region and characterize the non-linear and fracture properties of the material. These methods observe materials in compression/tension or shear. These types of methods relate well to sensory properties since mastication is a large strain action.

The mechanisms of material fracture and material yielding have been contrasted (van Vliet and Walstra, 1995). When stresses are applied to a material, the bonds between the structural elements along a specific plane begin to rupture, resulting in failure of the material's structure at a much greater scale than the length of the actual structural elements. In fracture, the material then falls apart due to the lack of structure. Conversely, in yielding, the result is material flow.

***Compression/tension fracture testing.*** Compression tests apply forces perpendicular to the material's surface. Specifically, the popular instrumental Texture Profile Analysis (TPA) is a compressive test in which a sample is compressed one to two times to mimic the actions occurring during human mastication.

The effects of fat, moisture content, and storage conditions on the texture of Mozzarella cheese were determined through using instrumental TPA (Tunick et al., 1991). Their results showed that low fat, low moisture Mozzarella cheese was texturally different than Mozzarella cheeses having different combinations of fat and moisture contents

regardless of the storage condition. However, they were able to create a low fat, high moisture Mozzarella cheese that was texturally equivalent to fresh full-fat cheese by storing the cheese for 6 weeks at 4° C. They hypothesized that the extra storage time allows for proteolysis of the casein matrix, producing a cheese that has more advantageous textural characteristics. Similarly, using compression methods, Fenelon and Guinee (2000) found that as fat content was reduced in Cheddar cheese, fracture stress, fracture strain, and firmness increased. Likewise, these parameters decreased over time as the cheese aged up to 225 days.

Tunick et al. (1993) used both small and large strain methods to differentiate low-fat and full-fat Mozzarella cheeses made from homogenized milk at different cook temperatures. Using instrumental TPA, they found that cheeses were harder at higher cooking temperatures. They hypothesized that at higher cook temperatures, less moisture would remain in the final cheese, resulting in a firmer casein network. The lower fat cheeses were also harder and springier. Likewise, with less fat filling the network, a more dense protein network would result. Additionally, their small strain results agreed with others in that the storage and loss moduli decreased with storage time due to proteolytic breakdown. However, the storage and loss moduli increased with increases in homogenization pressures. In homogenized milk, some casein is absorbed onto the lipid; the higher the homogenization pressure, the more casein is absorbed. They theorized that this casein could form crosslinks.

Hsieh et al. (1993) also used both large and small strain methods to see how the incorporation of different protein fillers into Mozzarella cheese affected the fracture and viscoelastic properties of the cheese. Mozzarella having soy protein incorporated produced cheeses with very strong networks, as was indicated by compression test results. Though

egg, whey, and caseinate did not increase the strength of the cheese network, all proteins considered in this study significantly influenced the magnitude of the storage and loss moduli as temperature of the final cheese decreased.

Compressive type tests have been criticized because friction between the surface of the sample and the compression plates contributes to the overall response of the material. For highly incompressible materials (Poisson's ratio is close to 0.5), the friction causes the sample to "barrel" or "bulge", rather than fracture (Kavanagh and Ross-Murphy, 1998). When a material behaves in this manner, the force being applied is no longer a true axial load. The use of lubrication can minimize the frictional effect.

In tensile tests, the samples are connected to an apparatus that pulls the sample apart until fracture occurs. Ak and Gunasekaran (1997) used large strain tensile testing to characterize the anisotropic nature of Mozzarella cheese. They found that when Mozzarella samples were pulled with the Mozzarella fibers parallel to the force applied, the fracture toughness, tensile strength, and fracture strain of samples was greater than when the same cheese was pulled with the fibers perpendicular to the force applied. This implied that the individual fibers are much stronger than the bonds that hold the fibers together.

Tensile tests have also been criticized because of the difficulty in attaching weaker materials to the apparatus and the tendency for materials to fail at the point of attachment. To overcome this problem, notches can be cut into the sample at a specific point to encourage failure at the notch rather than at the attachment site.

*Torsion fracture testing.* Torsion is another large strain method in which the sample is formed into a capstan shape of known dimensions. The capstan is then twisted at a chosen speed until it fractures. Due to its unique shape, the point of fracture can be forced at the

center of the capstan. Measurement of the dimensions of the capstan, the torque at fracture, and the time at fracture, are used to calculate stress and strain at fracture. Bowland and Foegeding (1999) identified textural changes in process cheese associated with changes in formulation and processing conditions using large-strain, torsional analysis. They were able to make cheeses characterized as being very brittle to very firm through altering processing time, salt solution pH, and disodium phosphate concentration (which ultimately altered moisture).

To compare compression-type tests with torsion, one must understand the differences in the types of stresses and strains obtained in each method. Stresses and strains are described as being dilatational or deviatoric. Dilatational stresses and strains cause changes in volume and shape; deviatoric parameters cause changes just in shape. When stresses and strains are dilatational, the resulting axial stress is twice the maximum shear stresses, and the resulting axial and shear strains are also skewed. However, in torsion tests, the stresses and strains are deviatoric; the method produces pure shear. The resulting normal and shear stresses are equal, and the resulting shear strains are twice the maximum normal strains (Hamann, 1983).

In cheese, torsional methods are more appropriate than compressive methods for studying fracture stresses and strains since cheese, being an incompressible material, may not be as sensitive to the shape changing stresses associated with compression tests. However, torsional methods have also been criticized due to the limitations of application (soft or sticky foods cannot be shaped easily into the capstan shape) and due to the extensive nature of the sample preparation.

*Vane testing.* The vane method is another large strain test. In this method, a vane,

having four to eight blades of specified diameter and length, is lowered into the sample and rotated at a defined speed. The vane method has been used to define spreadability in softer textured foods (Daubert et al., 1998). Additionally, yield stress and apparent yield strain were determined using the vane method to create texture maps describing cream cheese (Breidinger and Steffe, 2001). The vane method is advantageous due to its simplicity in sample preparation, its applicability to a wide range of food consistencies, and its ability to minimize sample destruction. However, it is questionable whether this method provides purely fundamental information for viscoelastic solids.

The ability of the vane and torsion methods to characterize cheeses (Full-fat, Low-fat, American yellow, and American white Process cheeses; Extra Sharp Cheddar, Deluxe Cheddar, and Mozzarella) has been compared (Truong and Daubert, 2001). Torsion shear stresses were higher than vane shear stresses, though comparing the placement of samples by the vane and torsion methods on texture maps showed that the relative placements of the samples were similar. This group concluded that the vane method would be appropriate to compare the textures of different cheeses, given that the diameter of the vane fracture surface was approximately equal to the diameter of the vane.

*Non-linear properties.* Measuring the non-linear properties of materials is difficult since in the non-linear range, compliance and modulus become functions of both the amount of stress (or strain) applied and rate of application (Bagley, 1983). Very little has been done to characterize large strain, pre-fracture properties in cheese due to the inherent difficulties of these methods. However, the rubber elastic model has been suggested to explain non-linear behavior in polymer systems. The rubber elastic state is defined for materials that display complete recovery after experiencing very large strains. Such materials consist of polymeric

chains, which have a high degree of flexibility and are joined into a network (Mark, 1993). The structure of casein gels is somewhat different than polymer systems in that they are formed by the random aggregation of particles into small clusters, which then aggregate further by cluster-cluster aggregation (van Vliet and Walstra, 1995).

### **Perceptual Texture Assessment**

Though rheological methods do provide an accurate characterization of the physical and chemical properties of cheese, using only these methods to understand cheese texture is inadequate. The rheological depiction must be paired with a human psychophysical interpretation of the tactile and visual perceptions that occur when consuming cheese in order to completely understand what causes differences in cheese texture. Quantification of human texture perception is difficult because of the many sensory systems involved. The tongue, teeth, and tissues lining the oral cavity all give clues as to the texture elements of the material. Feedback associated from the movement of oral muscles as the food is being chewed also differentiates a material's texture. Even sounds created by the manipulation of the material aid in determining texture (Christensen, 1984). Sensory science is the field that qualifies and quantifies these perceptions.

*Physiological processes.* In order to develop methodology that will accurately measure these perceptions, it is important to understand the physiological processes that occur in humans when eating. Textural perception begins with a visual assessment of the food (Guinard and Mazzucchelli, 1996). Initial clues as to how the food will feel in the mouth can be detected by how the food behaves on utensils or in hands and related to prior experience with similarly behaving foods. For example, soup appears to pour readily from a spoon, whereas wheat crackers look and feel coarse when picked up. From this, the

consumer would predict that the soup will feel smooth in the mouth whereas the cracker will seem crisp and dry (Rosenthal, 1999). Tactile sensitivity is unevenly distributed across body surfaces; the fingertips are the most sensitive area on the body in discriminating different textures, while the mouth, tongue, and lips are second best in discriminating textures (Guinard and Mazzucchelli, 1996).

Secondary evidence of the food's firmness and viscosity is collected by how the food is deposited in the consumer's mouth, either through biting with the incisors, licking with the tongue, or slurping with the lips, for example. Once the food is in the mouth, impressions of the food's homogeneity are then gathered through tactile sensing by the tongue and palate. It is during this stage that particle detection and porosity assessment occurs. Then, the tongue slightly shears the food causing initial deformation and flow; elasticity, stickiness, and viscosity are gauged. During the first few chews, much of the structure of the food is destroyed and many textural characteristics are observed such as crispness, brittleness, plasticity, and sponginess. Saliva mixes with the chewed food, further deforming and breaking down the material. Saliva serves many purposes including lubricating mouthparts, enhancing taste perception, providing enzymes for digestion, and preventing attack by acid and microorganisms on tooth enamel (Wilkinson et al., 2000).

Later stages of mastication are more regular in rate; attributes such as smoothness, consistency, and adhesion to mouth surfaces are measured. After swallowing, residual mouth coatings continue to impart textural experiences (Bourne, 1982; Szczesniak, 1998; Rosenthal, 1999). Though the order of these perceptions is basically the same for each person (Szczesniak, 1998), this magnitude and timing of this process is idiosyncratic. Chewing behavior plays an important part in how consumers perceive texture. For example,

individuals with shorter chewing times concentrate more on the initial properties of the food and tend to perceive soft foods as firmer and hard foods as less firm when compared to consumers with longer chewing times (Guinard and Mazzucchelli, 1996). Jack et al. (1993a) used quantitative descriptive analysis, large strain compression methods, and electromyology (EMG) to determine if differences in jaw muscle movements could predict textural perception. Predictions of sensory perceptions of cheeses using the EMG data were subject dependent. This study confirmed that different subjects had different masticatory patterns in response to different textures, which would account for variance seen in the sensory prediction relationships.

*Measuring perceptual processes.* In order to quantify what humans sense when completing the eating process, sensory descriptive methods are used to describe textural perceptions at the various stages of mastication. Such methods employ a panel of humans whom are trained to qualify and quantify these sensations. Szczesniak (1963) was a pioneer in developing a standard classification system for qualifying textural perception. In supplemental studies, standard reference scales were developed as a means to quantify the textures mentioned in the standard texture classification system (Szczesniak et al., 1963). Another group dissected texture perception into three phases (first bite, masticatory, and residual) and clarified what textures are perceived at each phase using the standard texture classification system (Brandt et al., 1963). Using this information, the scientists were able to develop the sensory texture profile method, which assessed the entire textural image from first bite through post-mastication.

Since then, many variations on the standard reference scale have been developed as well as methods by which textural lexicons can be generated (Munoz and Civille, 1998).



Methods to improve evaluation techniques have also been explored. Drake et al. (1999a) showed that both hand and mouth evaluation similarly differentiated the texture of a variety of cheeses. Terms like firmness, stickiness, and slipperiness showed a direct correlation between the two types of evaluation methods used.

Sensory descriptive methods can be used to differentiate cheese varieties. Two methods of descriptive profiling (free-choice profiling and conventional profiling) were compared in terms of their ability to differentiate seven types of Cheddar cheese (McEwan et al., 1989). Flavor, texture, mouthfeel, and odor were evaluated. Though both descriptive methods were able to differentiate the Cheddars, data collected using the conventional profiling method was slightly better at differentiating the samples than the free-choice profiling data. These profiles were then compared to hedonic data to determine what drives consumer preference. It was concluded that changes in certain textural characteristics impacted consumer preference in Cheddar cheese.

Sensory descriptive methods can be used to determine which specific textural characteristics are most desired in the marketplace. Bogue et al. (1999) were able to differentiate eight cheddar-type cheeses based upon data collected from a trained sensory descriptive panel. They then collected preference data from consumers and were able to determine five trends of cheese preference based upon the preferences given and the descriptive information. Using focus group information, they were able to match buying habits with these cheese characteristics and preferences. Similarly, objective descriptive information on eight Cheddar-type cheeses and their packages was paired with subjective preference information on the same cheeses and their packages (Murray and Delahunty, 2000). Such information has marketing as well as product development implications.

## **Relating Physical and Perceptual Texture**

Due to the extensive amount of resources that must be invested in generating and validating sensory data, many attempts have been made to discover instrumental methods which would mimic human sensory perception. Friedman et al. (1963) recognized that the action used to measure some sensory perceptions, in particular the mechanical properties of the mouth, could be mimicked using compressive rheological instrumentation. Such instrumentation could measure in an unbiased manner the physical condition of a sample in order for future comparison of sample texture to be possible. However, they noted that, while the instrumental mechanical measurements correlated well with the mechanical sensory perceptions, instrumentation could not accurately profile the entire sensory textural experience. This innovative work on the development of instrumentation laid the foundation for further exploration.

Correlations between sensory and rheological data have been used to differentiate and define different cheese varieties. Lee et al. (1978) attempted to correlate compressive measurements and data from a trained descriptive sensory panel for cheeses having a wide range of textures. They found sensory hardness correlated with instrumental measurements of compressive force, work ratio, adhesive force, and force at the inflection point. Sensory springiness related to elastic recovery and force at the inflection point, and sensory adhesiveness was related to adhesive force and inversely related to force at the inflection point. Similarly, Casiraghi et al. (1989) used a product-specific reference scale and compressive measurements on five varieties of Italian cheeses to show that perception of sensory hardness significantly correlates with instrumental hardness, but sensory chewiness does not correlate with instrumental chewiness measurements.

Using force-deformation, compositional analysis, and free-choice profiling, Jack et al. (1993b) attempted to discriminate nineteen different types of Cheddar cheese each having previously shown different perceived textures. They wanted to be able to suggest types of instrumental and sensory methods that could be used to predict texture using the foretold analytical relationships. The Cheddars showed significant differences rheologically, compositionally, and sensorally, however, there was limited correlation between the sensory and the instrumental methods. Though all types of measurements did differentiate the cheeses, each method used different characteristics of the cheeses to differentiate.

Drake et al. (1999b) used sensory descriptive methods, small strain rheological testing, and compressive instrumental methods to draw correlations between instrumental and sensory data and to differentiate natural and process cheeses. They showed that the compressive measurements alone could predict mouth and hand firmness. Additionally, they found that frequency sweep and creep recovery data together could predict the sensory attributes of mouth smoothness, hand rubberiness, and hand brittleness, however, these fundamental measurements alone were poor predictors of sensory attributes. They concluded that the compressive measurements were better able to predict sensory texture than the fundamental rheological tests.

Rheological and sensory methods can be used for complete characterization of cheeses, which has great implications in product development. Drake et al. (1999c) wanted to determine which textural attributes would be affected by the addition of soy lecithin in reduced-fat process cheese. They found that the lecithin addition affected firmness, cohesiveness, elasticity, toothpull, and smoothness of the mass. When compared to the full-fat and reduced-fat control cheeses, the addition made the test cheese's texture more like the

full-fat cheese than the reduced-fat cheese. In conclusion, lecithin addition to reduced-fat cheeses would likely provide health benefits without adversely affecting consumer acceptance.

Chen et al. (1979) wanted to define the texture of cheese and to investigate the relationships among composition, instrumental parameters, and sensory perception of the cheeses. They observed eleven different cheese varieties having a wide range of cheese compositions and textures. They were able to derive good correlations between their compressive and sensory data and to determine the impact of the components of the cheese on texture. Specifically, protein impacts texture the most followed by sodium chloride content, water content, pH, and fat content.

Likewise, relationships among composition, rheological properties, and sensory measurements were used to develop mathematical models that predict textural perception for seventeen different types of Cheddar cheese (Hort and Le Grys, 2000). Relationships between chemical and rheological parameters could not be established and likewise, data on chemical parameters did not predict textural perceptions. This was probably due to the small range of chemical compositions employed since only one type of cheese was observed. However, using all three types of information, accurate prediction equations were generated for springiness, firmness, log hand crumbliness, hardness by cutting, log creaminess, hardness on first bite, and graininess. Such equations could, again, impact product development efforts. Additionally, they found that the finger measured terms had more accurate models than palate measured terms (though models generated for palate measured terms were still highly significant).

Compressive tests have been used extensively in quality control applications

primarily due to their simplicity and economic value. Green et al. (1985) wanted to assess the usefulness and accuracy of this practice in cheeses that varied little in composition and maturity by comparing the mechanisms of fracture when cheeses were broken relevant to consumption. They used trained sensory panels and compressive rheological data to differentiate the cheeses, then employed scanning electron microscopic techniques to compare four different fractured surfaces (cheese broken with fingers, cheese bitten with teeth, cheese cut with wire, and cheese compressed with the Instron to fracture). They were unable to define more than 50% of the variance seen in the cheeses using the sensory and rheological data. However, when they looked at the surfaces of the fractured cheeses, they found that the way in which the fracture occurred in compression testing was different than how it was assessed sensorily. Likewise, Bendito et al. (2000) wanted to develop a more reliable way to assess texture in aging Mahon cheese. Correlations between instrumental and sensory assessment were very high for all texture parameters tested. Also, due to unique properties of this cheese variety (low degree of proteolysis and high surface moisture loss), firmness increased and elasticity and deformability decreased over time.

Breuil and Meullenet (2001) wanted to compare the ability of three large strain rheological methods (uniaxial compression, cone penetrometry, and puncture test) to predict cheese texture as observed by a trained panel. Overall, they were able to effectively predict six different textural characteristics using such methods to evaluate twenty-nine different cheese types. However, it was apparent that each of the instrumental techniques was best at determining different textural characteristics, implying that none of these methods are universally the best at defining the textural perception.

There are many complications associated with relating rheological and sensory data.

First, as mentioned earlier, mimicking the human sensory process is very difficult. Currently, rheological methods have not been able to accurately imitate physical changes that occur in the mouth due to saliva interactions, phase changes, and temperature changes. Second, mastication is a dynamic process (Christensen, 1984; Wilkinson et al., 2000). Traditional compressive rheological tests measure only a ‘single’ event: the forces and deformations associated with ‘first’ and sometimes ‘second’ bite during consumption. This represents only 2-10% of the total normal mastication time (Bourne, 1975). However, mastication is a series of simultaneous, sequential tests. The human takes one bite and breaks the food into two pieces, creating two ‘new samples’ which are smaller in size; these samples are then broken into smaller pieces creating more new samples with each bite. Third, human individual oral processes are highly idiosyncratic; instrumental methods cannot mimic each person’s particular chewing patterns (Wilkinson et al., 2000). Fourth, some compressive methods, such as instrumental TPA, are merely empirical in nature and do not convey much about the material’s fundamental properties. More work is needed to develop rheological measurements that mimic the small strain and non-linear sensory perceptions experienced during consumption. This type of work would prove valuable since such measurements deduce the physical and chemical properties of the material, relating to fundamental information.

## **CONCLUSIONS**

Though its constituents are relatively minimal, cheese is a highly complex biological material due to the many physical, chemical, and biochemical changes which occur during its formation and ripening periods. Deciphering the relative contributions of these different

elements to physical and perceptual texture is key in order to help cheese makers in their quest to custom make cheese. The objectives of this research are threefold: first, to define the fundamental properties of young cheeses and to see how such properties change as the cheeses age, including linear and non-linear viscoelastic properties, and fracture properties; second, to determine the human perception of the texture of such cheeses over the entire range of mastication; and third, to relate these physical and perceptual definitions in order to better understand what governs transitions in textural elements in young cheeses.

## REFERENCES

- Adda, J., J. C. Gripon, and L. Vassal. 1982. The chemistry of flavour and texture generation in cheese. *Food Chem.* 9:115-129.
- Ak, M. M., and S. Gunasekaran. 1997. Anisotropy in tensile properties of Mozzarella cheese. *J. Food Sci.* 62:1031-1033.
- Antoniou, K. D., R. Petridis, S. Raphaelides, Z. Ben Omar, and R. Kesteloot. 2000. Texture assessment of French cheeses. *J. Food Sci.* 65:168-172.
- Bagley, E. B. 1983. Large deformations in testing and processing of food materials. Pages 325-342 *in* *Physical Properties of Foods*. M. Peleg, ed. AVI Publishing Company, Inc., Westport, CT.
- Benedito, J., R. Gonzalez, C. Rossello, and A. Mulet. 2000. Instrumental and expert assessment of Mahon cheese texture. *J. Food Sci.* 65:1170-1174.
- Bogue, J. C., C. M. Delahunty, M. K. Henry, and J. M. Murray. 1999. Market-oriented methodologies to optimize consumer acceptability of Cheddar-type cheeses. *Brit. Food J.* 101:301-316.
- Bourne, M. C. 1975. Is rheology enough for food texture measurement? *J. Texture Stud.* 6:259-262.
- Bourne, M. C. 1982. *Food Texture and Viscosity: Concept and Measurement*. Academic Press, Inc., New York, NY.
- Bowland, E. L., and E. A. Foegeding. 1999. Factors determining large-strain (fracture) rheological properties of model processed cheese. *J. Dairy Sci.* 82: 1851-1859.
- Brandt, M. A., E. Z. Skinner, and J. A. Coleman. 1963. Texture profile method. *J. Food Sci.* 28:404-409.



- Breidinger, S. L., and J. F. Steffe. 2001. Texture map of cream cheese. *J. Food Sci.* 66:453-456.
- Breuil, P., and J. F. Meullenet. 2001. A comparison of three instrumental tests for predicting sensory texture profiles of cheese. *J. Texture Stud.* 32:41-55.
- Casiraghi, E., M. Lucisano, and C. Pompei. 1989. Correlation among instrumental texture, sensory texture and chemical composition of five Italian cheeses. *Ital. J. Food Sci.* 1:53-63.
- Chen, A. H., J. W. Larkin, C. J. Clark, and W. E. Irwin. 1979. Textural analysis of cheese. *J. Dairy Sci.* 62:901-907.
- Christensen, C. M. 1984. Food texture perception. *Adv. Food Research.* 29:159-199.
- Creamer, L. K., and N. F. Olson. 1982. Rheological evaluation of maturing Cheddar cheese. *J. Food Sci.* 47:631-636.
- Dalgleish, D. G. 1992. The enzymatic coagulation of milk. Pages 579-619 *in* *Advanced Dairy Chemistry-1: Proteins*. Vol. 1. P. F. Fox, ed. Blackie Academic and Professional, New York, NY.
- Dalgleish, D. G. 1997. Structure-function relationships of caseins. Pages 199-223 *in* *Food Proteins and Their Applications*. S. Damodaran and A. Paraf, ed. Marcel Dekker, Inc., New York, NY.
- Daubert, C. R., J. A. Tkachuk, and V. D. Truong. 1998. Quantitative measurement of food spreadability using the vane method. *J. Texture Stud.* 29:427-435.
- de Jong, L. 1976. Protein breakdown in soft cheese and its relation to consistency: 1. Proteolysis and consistency of 'Noordhollandse Meshanger' cheese. *Neth. Milk Dairy J.* 30:242-253.

- Drake, M. A., P. D. Gerard, and G. V. Civille. 1999a. Ability of hand evaluation versus mouth evaluation to differentiate texture of cheese. *J. Sens. Stud.* 14:425-441.
- Drake, M. A., P. D. Gerard, V. D. Truong, and C. R. Daubert. 1999b. Relationship between instrumental and sensory measurements of cheese texture. *J. Texture Stud.* 30:451-476.
- Drake, M. A., V. D. Truong, and C. R. Daubert. 1999c. Rheological and sensory properties of reduced-fat processed cheeses containing lecithin. *J. Food Sci.* 64:744-747.
- Fenelon, M. A., and T. P. Guinee. 2000. Primary proteolysis and textural changes during ripening in Cheddar cheeses manufactured to different fat contents. *Int. Dairy J.* 10:151-158.
- Fox, P. F. 1989. Proteolysis during cheese manufacture and ripening. *J. Dairy Sci.* 72:1379-1400.
- Friedman, H. H., J. E. Whitney, and A. S. Szczesniak. 1963. The texturometer- a new instrument for objective texture measurement. *J. Food Sci.* 28:390-396.
- Geurts, T. J., P. Walstra, and H. Mulder. 1972. Brine composition and the prevention of the defect 'soft rind' in cheese. *Neth. Milk Dairy J.* 26:168-179.
- Geurts, T. J., P. Walstra, and H. Mulder. 1974. Transport of salt and water during salting of cheese: 1. Analysis of the processes involved. *Neth. Milk Dairy J.* 28:102-129.
- Geurts, T. J., P. Walstra, and H. Mulder. 1980. Transport of salt and water during salting of cheese: 2. Quantities of salt taken up and of moisture loss. *Neth. Milk Dairy J.* 34:229-254.

- Green, M. L., R. J. Marshall, and B. E. Booker. 1985. Instrumental and sensory texture assessment and fracture mechanisms of Cheddar and Cheshire cheese. *J. Texture Stud.* 16:351-364.
- Green, M. L., A. Turvey, and D. G. Hobbs. 1981. Development of structure and texture in Cheddar cheese. *J. Dairy Research.* 48:343-355.
- Guinard, J. X., and R. Mazzucchelli. 1996. The sensory perception of texture and mouthfeel. *Trends Food Sci. Technol.* 7:213-219.
- Guinee, T. P., M. A. E. Auty, and M. A. Fenelon. 2000. The effect of fat content on the rheology, microstructure and heat-induced functional characteristics of Cheddar cheese. *Int. Dairy J.* 10:277-288.
- Guinee, T. P., and P. F. Fox. 1987. Salt in cheese: physical, chemical and biological aspects. Pages 251-297 *in* *Cheese: Chemistry, Physics, and Microbiology*. Vol. 1. P. F. Fox, ed. Elsevier Science Publishing Company, Inc., New York, NY.
- Gunasekaran, S., and M. M. Ak. 2000. Dynamic oscillatory shear testing of foods- selected applications. *Trends Food Sci. Technol.* 11:115-127.
- Guo, M. R., J. A. Gilmore, and P. S. Kindstedt. 1997. Effect of sodium chloride on the serum phase of Mozzarella cheese. *J. Dairy Sci.* 80:3092-3098.
- Guo, M. R., and P. S. Kindstedt. 1995. Age-related changes in the water phase of Mozzarella cheese. *J. Dairy Sci.* 78:2099-2107.
- Hamann, D. D. 1983. Structural failure in solid foods. Pages 351-383 *in* *Physical Properties of Foods*. M. Peleg and E. B. Bagley, ed. AVI Publishing Company, Inc., Westport, CT.

- Hort, J., and G. Le Grys. 2000. Rheological models of Cheddar cheese texture and their application to maturation. *J. Texture Stud.* 31:1-24.
- Hsieh, Y. L., J. J. Yun, and M. A. Rao. 1993. Rheological properties of Mozzarella cheese filled with dairy, egg, soy proteins, and gelatin. *J. Food Sci.* 58:1001-1004.
- Jack, F. R., J. R. Piggott, and A. Paterson. 1993a. Relationships between electromyography, sensory and instrumental measures of Cheddar cheese texture. *J. Food Sci.* 58:1313-1317.
- Jack, F. R., J. R. Piggott, and A. Paterson. 1993b. Relationships between rheology and composition of Cheddar cheeses and texture as perceived by consumers. *Int. J. Food Sci. Technol.* 28:293-302.
- Kavanagh, G. M., and S. B. Ross-Murphy. 1998. Rheological characterization of polymer gels. *Prog. Polym. Sci.* 23:533-562.
- Konstance, R. P., and V. H. Holsinger. 1992. Development of rheological test methods for cheese. *Food Technol.* 46:105-109.
- Lawrence, R. C., L. K. Creamer, and J. Gilles. 1987. Cheese ripening technology- texture development during cheese ripening. *J. Dairy Sci.* 70:1748-1760.
- Lee, C. H., E. M. Imoto, and C. Rha. 1978. Evaluation of cheese texture. *J. Food Sci.* 43:1600-1605.
- Lucey, J., and J. Kelly. 1994. Cheese yield. *J. Soc. Dairy Technol.* 47:1-13.
- Ma, L., M. A. Drake, G. V. Barbosa Canovas, and B. G. Swanson. 1996. Viscoelastic properties of reduced-fat and full-fat cheddar cheeses. *J. Food Sci.* 61:821-823.

- Mark, J. E. 1993. The rubber elastic state. Pages 3-59 *in* Physical Properties of Polymers. J. E. Mark, A. Eisenberg, W. W. Graessley, L. Mandelkern, E. T. Samulski, J. L. Koenig, and G. D. Wignall, ed. American Chemical Society, Washington, D.C.
- McEwan, J. A., J. D. Moore, and J. S. Colwill. 1989. The sensory characteristics of Cheddar cheese and their relationship with acceptability. *J. Soc. Dairy Technol.* 42:112-117.
- Munoz, A. M., and G. V. Civille. 1998. Universal, product and attribute specific scaling and the development of common lexicons in descriptive analysis. *J. Sens. Stud.* 13:57-75.
- Murray, J. M., and C. M. Delahunty. 2000. Mapping consumer preference for the sensory and packaging attributes of Cheddar cheese. *Food. Qual. Prefer.* 11:419-435.
- Nolan, E. J., V. H. Holsinger, and J. J. Shieh. 1989. Dynamic rheological properties of natural and imitation Mozzarella cheese. *J. Texture Stud.* 20:179-189.
- Paulson, B. M., D. J. McMahon, and C. J. Oberg. 1998. Influence of sodium chloride on appearance, functionality, and protein arrangements in nonfat Mozzarella cheese. *J. Dairy Sci.* 81:2053-2064.
- Prentice, J. H. 1972. Rheology and texture of dairy products. *J. Texture Stud.* 3:415-458.
- Prentice, J. H. 1987. Cheese rheology. Pages 299-344 *in* Cheese: Chemistry, Physics, and Microbiology. Vol. 1. P. F. Fox, ed. Elsevier Science Publishing Company, Inc., New York, NY.
- Richardson, T, S. Oh, R. Jiménez-Flores, T. F. Kumonsinski, E. M. Brown, and H. M. Farrell, Jr. 1992. Molecular modeling and genetic engineering. Pages 545-578 *in* Advanced Dairy Chemistry-1: Proteins. Vol. 1. P. F. Fox, ed. Blackie Academic and Professional, New York, NY.

- Rosenberg, M., Z. Wang, S. L. Chuang, and C. F. Shoemaker. 1995. Viscoelastic property changes in Cheddar cheese during ripening. *J. Food Sci.* 60:640-644.
- Rosenthal, A. J. 1999. Relation between instrumental and sensory measures of food texture. Pages 1-29 *in* Food Texture. Aspen Publishers, Inc., Gaithersburg, MD.
- Ross-Murphy, S. B. 1995. Structure-property relationships in food biopolymer gels and solutions. *J. Rheol.* 39:1451-1463.
- Rowney, M., P. Roupas, M. W. Hickey, and D. W. Everett. 1999. Factors affecting the functionality of Mozzarella cheese. *Aust. J. Dairy Technol.* 54:94-102.
- Scott, R. 1998. Cheesemaking Practice. Aspen Publishers, Inc., Gaithersburg, MD.
- Steffe, J. F. 1996. Rheological Methods in Food Process Engineering. Freeman Press, East Lansing, MI.
- Subramanian, R., and S. Gunasekaran. 1997a. Small amplitude oscillatory shear studies on Mozzarella cheese: Part I. Region of linear viscoelasticity. *J. Texture Stud.* 28:633-642.
- Subramanian, R., and S. Gunasekaran. 1997b. Small amplitude oscillatory shear studies on Mozzarella cheese: Part II. Relaxation spectrum. *J. Texture Stud.* 28:643-656.
- Swaigood, H. E. 1992. Chemistry of the caseins. Pages 63-110 *in* Advanced Dairy Chemistry- 1: Proteins. Vol. 1. P. F. Fox, ed. Blackie Academic and Professional, new York, NY.
- Szczesniak, A. S. 1963. Classification of textural characteristics. *J. Food Sci.* 28:385-389.
- Szczesniak, A. S. 1998. Sensory texture profiling- historical and scientific perspectives. *Food Technol.* 52:54-57.

- Szczesniak, A. S., M. A. Brandt, and H. H. Friedman. 1963. Development of standard rating scales for mechanical parameters of texture and correlation between the objective and the sensory methods of texture evaluation. *J. Food Sci.* 28:397-403.
- Taneya, S., T. Izutsu, T. Kimura, T. Shioya, W. Buchheim, P. S. Kindstedt, and D. G. Pechak. 1992. Structure and rheology of string cheese. *Food Struct.* 11:61-71.
- Tolstoguzov, V. B., and E. E. Braudo. 1983. Fabricated foodstuffs as multicomponent gels. *J. Texture Stud.* 14:183-212.
- Truong, V. D., and C. R. Daubert. 2001. Textural characterization of cheeses using vane rheometry and torsion analysis. *J. Food Sci.* 66:716-721.
- Tunick, M. H. 2000. Rheology of dairy foods that gel, stretch, and fracture. *J. Dairy Sci.* 83:1892-1898.
- Tunick, M. H., K. L. Mackey, P. W. Smith, and V. H. Holsinger. 1991. Effects of composition and storage on the texture of Mozzarella cheese. *Neth. Milk Dairy J.* 45:117-125.
- Tunick, M. H., E. L. Malin, P. W. Smith, J. J. Shieh, B. C. Sullivan, K. L. Mackey, and V. H. Holsinger. 1993. Proteolysis and rheology of low-fat and full-fat Mozzarella cheeses prepared from homogenized milk. *J. Dairy Sci.* 76:3621-3628.
- Tunick, M. H., E. J. Nolan, J. J. Shieh, J. J. Basch, M. P. Thompson, B. E. Maleeff, and V. H. Holsinger. 1990. Cheddar and Cheshire cheese rheology. *J. Dairy Sci.* 73:1671-1675.
- van Vliet, T., and P. Walstra. 1983. Rheology of curd and cheese. *Neth. Milk Dairy J.* 37:93-94.
- van Vliet, T., and P. Walstra. 1995. Large deformation and fracture behaviour of gels. *Faraday Discuss.* 101:359-370.

Wendin, K., M. Langton, L. Caous, and C. Hall. 2000. Dynamic analyses of sensory and microstructural properties of cream cheese. *Food Chem.* 71:363-378.

Wilkinson, C., G. B. Dijksterhuis, and M. Minekus. 2000. From food structure to texture. *Trends Food Sci. Technol.* 11:442-450.



**CHANGES IN RHEOLOGICAL PROPERTIES OF YOUNG CHEESES DURING  
MATURATION**

**J. A. Brown, E. A. Foegeding, and C. R. Daubert**

Department of Food Science  
North Carolina State University

## ABSTRACT

Cheese is a popular food due to its diversity in application, nutritional value, convenience, and good taste. Producing high quality cheeses that meet consumer expectations is crucial in order for cheese makers to remain competitive. These expectations include end-use functionality (shred, melt, stretch, etc.) and proper texture. Currently, there is not a complete understanding of what characteristics govern these aspects. This study seeks to define physical properties of young cheeses in order to understand their role in perceived cheese texture. Mozzarella and Pizza cheeses were tested at 4, 10, 17, and 38 d of age; Process cheese was tested at 4 d. Rheological methods were employed to determine the linear and non-linear viscoelastic, and fracture properties of the cheeses. These methods were able to differentiate the cheese varieties, and patterns were observed as the cheeses aged. Rheological analyses showed the cheeses were viscoelastic, weak gels with greater storage ( $G'$ , elastic) than loss ( $G''$ , viscous) moduli. The overall magnitude of  $G'$  decreased as the cheeses aged; creep recovery analysis confirmed the loss of overall firmness, showing an increase in compliance with time. Correlations among the rheological methods were observed. Principal component analysis (three principal components explained 87.9% of the variance) showed that as cheeses aged, their solid-like response ( $G'$  and fracture modulus) decreased while their phase angle, maximum compliance and retardation time increased. The varieties of the cheeses were also differentiated primarily due to their  $G''$  response and to instantaneous compliance. These results have significant implications in the cheese industry; by understanding the physicochemical transitions that occur during the early stages of aging, cheese makers can understand how to better customize cheese texture.

**(Key Words:** cheese, texture, rheology)

**Abbreviation key:**  $G^*$ = Complex modulus,  $G'$ = Storage modulus,  $G''$ = Loss modulus,  $\delta$ = Phase angle,  $J$ = Compliance,  $\sigma$ = Stress,  $\gamma$ = Strain,  $\lambda_{ret}$ = Retardation time,  $J_0$ = Instantaneous compliance,  $J_{mx}$ = Maximum compliance,  $crp$ = Percent creep recovery,  $(J_r)_{eq}$ = Equilibrium relaxation compliance,  $L_{tot}$ = Total cylinder length,  $L_{curve}$ = Length of capstan curved section,  $r_{total}$ = Radius of upper edge of capstan,  $r_{min}$ = Minimum radius of capstan curved section,  $\sigma_t$ = True shear stress,  $\gamma_{t-true}$ = True shear strain,  $M$ = Torque,  $\phi_s$ = Angular deformation of capstan curved section,  $K$ = Shape factor constant,  $Q$ = Curvature section constant,  $G_f$ = Shear fracture modulus,  $PC1$ = Principal component one,  $PC2$ = Principal component two,  $PC3$ = Principal component three

## INTRODUCTION

In many countries, cheese is a dietary staple. Cheese-making has historically been a way to preserve the most desirable components of milk. Cheese is considered an ideal food due to its high nutrition, convenience, variety, availability, and good taste (Bogue et al., 1999). With the widespread popularity and production of this food, the consumers' palate is becoming more discriminating when determining cheese purchases. Now, more than ever, producing high quality cheeses is crucial in order for cheese makers to remain competitive.

One such consumer expectation is that the selected cheese possesses an expected texture, characteristic of that particular variety. Texture is an important characteristic used to differentiate many cheese varieties (Antoniou et al., 2000; Wendin et al., 2000) and is considered by the consumer to be a determinant of overall quality and preference (Lee et al., 1978; Adda et al., 1982; McEwan et al., 1989; Guinard and Mazzucchelli, 1996).

The structure of cheese fits a filled gel model. A filled gel is described as a

multicomponent material in which one of the components is a gelling agent that forms a continuous network and the other component(s) acts to fill in the network (Tolstoguzov and Braudo, 1983). Cheese is composed of a continuous, three-dimensional network of primarily casein. When this protein network forms during coagulation, it entraps fat globules and moisture contained in the milk forming the filler component (Prentice, 1987).

Much of the major changes in this structure, which ultimately affects final texture, occur during storage. Typically, as cheeses age, a decrease in firmness (or softening) of the body occurs. Two phases of texture development during storage have been identified. Phase one occurs within the first seven to 14 d after production. During this time, the rubbery texture of the young cheese is converted into the more smooth characteristic texture of the specific variety. In this phase, hydrolysis by residual coagulant of about 20% of the  $\alpha_{s1}$ -casein occurs, producing the  $\alpha_{s1}$ -I peptide; this action causes a weakening of the casein network (de Jong, 1976; Lawrence et al., 1987). The  $\alpha_{s1}$ -I peptide is present in all cheeses during the early stages of ripening. A more gradual change in cheese texture occurs during phase two of ripening. It is during this time period that the rest of the  $\alpha_{s1}$ -casein and the other caseins are hydrolyzed. Unlike phase one, which takes only days, phase two occurs over a period of months (Lawrence et al., 1987). It has been shown that the  $\beta$ -casein does not change as much as  $\alpha_{s1}$ -casein during ripening (de Jong, 1976; Creamer and Olson, 1982).

Defining certain fundamental properties of a material's structure is imperative in order to understand the principles of texture generation in cheese. Rheological methods have been used to observe such properties. Rheology is the study of the deformation and flow of materials (Steffe, 1996). Such methods measure the mechanical properties of the materials

under various loading conditions. Cheese is a viscoelastic material in that it exhibits both solid-like and fluid-like behavior (van Vliet and Walstra, 1983; Konstance and Holsinger, 1992; Taneya et al., 1992). Small strain dynamic rheological methods have been used to define both the elastic and viscous nature of cheese. Such information has been used to characterize and differentiate cheese varieties (Nolan et al., 1989; Tunick et al., 1990), to show the impact of cheese formulation and storage practices (Rosenberg et al., 1995; Ma et al., 1996; Subramanian and Gunasekaran, 1997a; 1997b), and to understand mechanisms of typical end-use functions (Guinee et al., 2000). Small strain methods are implemented within the linear viscoelastic region of the material and therefore, are designed to be non-destructive to the basic structure of the material (van Vliet and Walstra, 1983). Additionally, by performing such tests within the linear viscoelastic region, the elastic and loss moduli become only a function of time and not a function of the magnitude of the stress or strain applied (Tunick, 2000).

In addition to small strain rheological methods, large strain methods are also used to characterize cheese texture; large strain measurements occur outside of the linear viscoelastic region and characterize the non-linear and fracture properties of the material. Results from such studies have characterized certain cheese varieties (Ak and Gunasekaran, 1997; Tunick et al., 1993) and have shown the influence of changing formulation and processing practices on texture (Bowland and Foegeding, 1999; Fenelon and Guinee, 2000; Tunick et al., 1991). Combinations of both large and small strain methods have also been implemented (Hsieh et al., 1993).

Physical gels are defined as materials that are made of chains that are non-covalently crosslinked into networks. Though both strong physical gels and weak physical gels behave

as solids at small deformations, these two classes of physical gels differ at larger deformations. Strong physical gels behave as solids at larger deformations, whereas the viscous component is more dominant in weak physical gels; weak gels are defined as being structured fluids (Kavanagh and Ross-Murphy, 1998).

Though its constituents are relatively minimal, cheese is a highly complex biological material due to the many physical, chemical, and biochemical changes which occur during its formation and ripening periods. A comprehensive rheological characterization to define the transitions that occur during the early stages of maturation would aid in deciphering the texture maturation process of cheeses. Such information would help cheese makers in their quest to make cheeses with desirable textures and attributes. The objective of this research was to define the fundamental rheological properties of young cheeses and to see how such properties change as the cheeses age, including linear and non-linear viscoelastic properties, and fracture properties.

## **MATERIALS AND METHODS**

### **Material Description**

The rheological properties of three cheese varieties were observed: Mozzarella, Pizza cheese, and High melt process cheese (referred to as Process cheese). On two different occasions, all cheeses were manufactured by cheese makers and collected at the time of manufacture. Mozzarellas were manufactured by Alto Dairy Cooperative (Waupun, WI), Pizza cheeses were crafted by Meister Cheese Company (Muscodia, WI), and Process cheeses were made by Kraft (Glenview, IL). Cheeses were shipped to North Carolina State University using temperature-controlled packaging materials to ensure the cheeses remained

at appropriate temperatures during shipping. The cheeses were shipped immediately following manufacture, and all aging occurred at North Carolina State University. Cheeses were stored at 4° C in 4.5 kg blocks in Cryovac B series, vacuum-sealed bags. Testing of the Mozzarella and Pizza cheeses occurred at 4, 10, 17, and 38 d of age; Process cheese was tested at 4 d of age. Approximately 3-cm of the outer rind of the cheeses was discarded immediately prior to sample preparation; additionally, cheeses were allowed to temper to room temperature before performing any of the rheological tests.

### **Rheological Analysis**

*Small strain analysis.* Dynamic oscillatory measurements were done using a Bohlin VOR controlled strain rheometer (Bohlin Reologi AB, Lund, Sweden) fitted with 30-mm diameter serrated parallel plates and an 11.085-g-cm torque bar. The use of the serrated plates prevented specimen slippage. Cheeses were sliced to a 2-mm thickness and placed onto the lower plate surface; the upper plate was then lowered so that a 2-mm gap existed between the upper and lower plates. The edges of the samples were then cut to fit the exact dimensions of the plates. A thin film of synthetic lubricant (Superlube- Loctite Corporation, Rocky Hill, CT) was applied to the exposed edges of the sample to prevent moisture loss. A circulating water bath ensured that the sample temperature was maintained at 25° C.

Values of complex modulus ( $G^*$ ), storage modulus ( $G'$ ), loss modulus ( $G''$ ), and phase angle ( $\delta$ ) were obtained under two conditions. First, strain sweeps were run on all samples in order to determine the linear viscoelastic region. In these tests, the frequency of the oscillation was held constant and the amount of strain was varied over a specified range. Frequencies of 0.001, 0.01, 0.1, and 1.0 Hz were observed over a strain range of  $1.5 \times 10^{-4}$  to  $1.5 \times 10^{-1}$ . These frequencies correspond to maximum strain rates of 0.047, 0.47, 4.7, and 47

$s^{-1}$ , which allows for comparison to large strain data collected at similar shear strain rates. Second, frequency sweeps were done on all samples in order to characterize changes in the viscous and elastic behavior with changes in the rate of strain application. In such tests, the maximum amount of strain is sinusoidally varied while the frequency (or rate of strain application) changes. Three frequency sweeps were completed on each treatment replication at a constant strain within the linear viscoelastic region (as determined by the strain sweep) starting at 0.001 Hz continuing systematically up to 20 Hz then returning step-wise to 0.001 Hz.

In creep recovery tests, the material is subjected to a constant stress for a given time period, while the corresponding strain is measured. Then the stress is removed, and again, the corresponding strain is measured for a given time period as the material attempts to return to the original shape. Mathematically, compliance ( $J$ ) is represented by

$$J = \frac{\gamma}{\sigma_{\text{constant}}}$$

where  $\sigma_{\text{constant}}$  is the constant stress applied and  $\gamma$  is the resulting strain. Such tests were done on the cheese samples using a Stress Tech controlled stress rheometer (ATS Rheosystems, Bordentown, NJ) fitted with 20-mm diameter, smooth parallel plates. Samples were sliced into 2-mm thick slices and glued to the bottom plate with a dot of cyanoacrylate glue (Loctite 100- Loctite Corporation, Rocky Hill, CT). A second dot of the same glue was placed on the top of the sample and the upper plate was lowered to come into contact with the sample. The sample was then trimmed to fit the plate size, and a thin film of synthetic lubricant (Superlube- Loctite Corporation, Rocky Hill, CT) was applied to prevent moisture loss. All tests occurred at a stress within the linear viscoelastic region as determined by stress sweeps.



(Stress sweeps were run at 1.0 Hz from 0 to 500 Pa in order to confirm the linear viscoelastic region determined previously using the controlled strain rheometer.) The creep portion of each test consisted of a stress application for 600 s; the stress was then removed and measurements of recovery were made for an additional 1200 s. Strain rates in this test ranged from  $1.7 \cdot 10^{-5}$  to  $1.0 \cdot 10^{-3} \text{ s}^{-1}$ . Temperature was maintained at 25° C using an induction heating device. Three creep-recovery tests were done for each treatment replication.

Retardation time ( $\lambda_{\text{ret}}$ ) gives an indication of the time needed for a substance to reach full deformation and is determined by the time required for the delayed strain to reach 1-1/e (63.2%) of its final value (Steffe, 1996). Instantaneous compliance ( $J_0$ ) is the compliance at time zero and has been shown to be an indication of firmness in cheese (Drake et al., 1999); instantaneous compliance was determined through extrapolation of the creep curve to time zero. Maximum compliance ( $J_{\text{mx}}$ ) is the peak compliance reached by the material generally just before the constant stress is removed. Percent creep recovery (crp) gives an indication of the degree of elasticity in the material and was calculated using the following relationship:

$$crp = \frac{(J_{\text{mx}}) - (J_r)_{\text{eq}}}{(J_{\text{mx}})} * 100$$

where  $J_{\text{mx}}$  is the maximum creep compliance and  $(J_r)_{\text{eq}}$  is the equilibrium relaxation compliance.

**Large strain analysis.** Torsional methods were used to determine the non-linear and fracture properties of the cheeses. Cylinders of cheese were formed using a 19-mm internal diameter cork borer. The cylinders were cut to a length of 28.7-mm, and plastic disks (Gel Consultants, Raleigh, NC) were glued to the ends of the cylinder using cyanoacrylate glue

(Loctite 100- Loctite Corporation, Rocky Hill, CT) to enable the samples to be mounted to the grinding and twisting apparatuses. The cylinders were shaped into a capstan shape having a minimum diameter of 10-mm using a precision grinding machine (Gel Consultants, Raleigh, NC). Measurements of the total cylinder length ( $L_{tot}$ ), length of curved section ( $L_{curve}$ ), upper cylinder radius ( $r_{total}$ ), and minimum radius ( $r_{min}$ ) were taken in order to calculate the geometry of the curved section. Figure 1 illustrates the capstan geometry.

Samples were twisted using a Haake 550 viscotester (Gebruder Haake GmbH, Karlsruhe, Germany) fitted with a fabricated apparatus that enabled torsional measurement (Truong and Daubert, 2000). The capstans were twisted at 0.045, 0.45, and 4.5 rpm, and three replications at each speed of each treatment replication was made. These speeds correspond to strain rates of 0.0047, 0.047, and 0.47 s<sup>-1</sup> allowing for comparison with strain sweeps at similar strain rates.

True shear stress ( $\sigma_t$ ) and true shear strain ( $\gamma_{t-true}$ ) were calculated at each point from time at zero to time at fracture using the following relationships (Nadai, 1937; Diehl et al., 1979; Hamann, 1983):

$$\sigma_t = \frac{2KM}{\pi r_{min}^3}$$

$$\gamma_t = \frac{2K\phi_s}{\pi r_{min}^3 Q}$$

$$\gamma_{t-true} = \ln \left[ 1 + \frac{\gamma_t^2}{2} + \gamma_t \left( 1 + \frac{\gamma_t^2}{4} \right)^{1/2} \right]$$

where  $r_{min}$  is the minimum capstan radius, K is the shape factor constant (equal to 1.08), M is the torque (N m),  $\phi_s$  is the angular deformation of the curved section, and Q is the

curvature section constant (equal to  $8.45 \cdot 10^{-6} \text{ m}^{-3}$ ).

From these equations, the shear fracture modulus ( $G_f$ ) was calculated according to the following equation (Bowland and Foegeding, 1995):

$$G_f = \frac{\sigma_t}{\gamma_{t\text{-true}}}$$

where  $\sigma_t$  is the true shear stress and  $\gamma_{t\text{-true}}$  is the true shear strain.

### **Statistical Analysis**

The large strain, non-linear data was fitted to a power law curve using Sigma Plot (Version 6.10, SPSS, Inc., Chicago, IL). Correlation analysis (PROC CORR) using the SAS statistical software package (Version 8.2, SAS Institute, Inc., Cary, NC) allowed determination of relationships between individual instrumental parameters. The experimental unit used for the correlation analysis was the mean of each variety x age x batch treatment (n=18). Principal component analysis (PROC PRINCOMP) was used to decrease the number of dimensions (see Table 1 for original dimensions) and to make visual comparisons of how the instrumental and sensory variables differentiated the cheeses. The experimental unit used for the correlation analysis was also used for the principal component analysis.

## **RESULTS AND DISCUSSION**

### **Viscoelastic Properties**

Results of the viscoelastic characterization of each of the cheeses over time are shown in Figure 2. Overall, the magnitude of the storage modulus ( $G'$ ) was higher for all samples than the magnitude of the loss modulus ( $G''$ ), and  $G'$  increased with increasing frequency.

The results suggest that the cheeses were viscoelastic, weak gels (Kavanagh and Ross-Murphy, 1998). This behavior is characteristic in cheese (Nolan et al., 1989; Tunick et al., 1990; Ma et al., 1996; Tunick, 2000). The storage modulus defines the amount of energy stored by the material (Steffe, 1996) and characterizes the elastic element of the material, which, in cheese, is an indication of the rigidity of the protein network and the elasticity of the filler component (Prentice, 1987). The loss modulus characterizes the viscous component of the material and defines the amount of energy dissipated (Steffe, 1996); the viscous component is related to flow of the filler through the network (Konstance and Holsinger, 1992).

The effect of aging on  $G'$  can be seen in Figure 2. The magnitude of  $G'$  in both the Mozzarella and Pizza cheeses changed as the cheeses aged, though the trends in which  $G'$  changed over time differentiated these cheeses. Pizza cheese showed a consistent decrease in  $G'$  at each day of testing whereas Mozzarella cheese showed a sharp decrease in  $G'$  between 4 d and 10 d, then an increase by 17 d, then a decrease by 38 d. It has been shown that over extended periods of aging (greater than the period used in this research)  $G'$  and  $G''$  decreases with aging in Cheddar cheeses (Rosenberg et al., 1995) and in Mozzarella cheese (Subramanian and Gunasekaran, 1997b). Process cheese showed the highest magnitude of  $G'$  of all of the treatments.

As cheeses age, several reactions are occurring. Hydrolysis by residual coagulant of the  $\alpha_{s1}$ -casein causes a weakening of the casein network (de Jong, 1976; Creamer and Olson, 1982; Lawrence et al., 1987). Such changes in the matrix would account for the increased overall softening of the cheeses as they aged.

It is hypothesized that the differences in method of salt application during the manufacture of these cheeses may partially explain the differences over time seen between Mozzarella and Pizza cheeses. Mozzarella cheese was immersed into brine while Pizza cheese had a direct application of salt. As a result, immediately after manufacture, Mozzarella cheese had a high concentration of salt at the edge of the block while Pizza cheese had salt evenly distributed throughout the block. Though the outer edge of the samples was cut off, an uneven distribution of salt still existed in 10 d Mozzarella due to the brine migration, accounting for the skew downward in  $G'$ . Brine migration patterns and rates have been modeled (Geurts et al., 1974; 1980); the pseudo diffusion coefficient of sodium chloride through the moisture in Gouda cheese was estimated to be a rate of  $0.2\text{-cm}^2\text{ day}^{-1}$ . For the blocks used in this research, it was estimated that two weeks were needed for the brine to thoroughly migrate through the Mozzarella blocks. Once the cheese reached 17 d of age, the brine had equilibrated through the block and the decreasing trends in  $G'$  were due to continual proteolysis of the casein network described earlier.

Both the matrix and the serum phases of cheese are affected by sodium chloride in the brine, which, in turn, affects the overall texture. Sodium chloride in the serum phase of Mozzarella cheese promotes the microstructural swelling of the para-casein matrix resulting in an increased water-holding capacity and formation of a hydrated gel. Simultaneously, the sodium chloride promotes the solubilization of intact caseins from the para-casein matrix; it is hypothesized that these proteins are able to freely migrate between the matrix and the serum phase (Guo and Kindstedt, 1995; Guo et al., 1997). The calcium phosphate bonds that connect the bare casein micelles in the protein matrix are affected by demineralization. The sodium ions are able to displace the calcium ions in the calcium phosphate bond. This allows

for water in the system to be able to bind to the complex, either increasing the water holding capacity of the matrix, or promoting the protein to become soluble in the serum (Geurts et al., 1972).

The effects of aging on  $G''$  are also seen in Figure 2; similar patterns in aging were observed in  $G''$  that were seen in  $G'$ . As the cheese ages, continual proteolysis of the caseins by residual rennet causes an increase in the viscosity of the filler component, resulting in a slight decrease in  $G''$ . It has been shown that proteins have a dynamic relationship in the cheese system; they are able to freely go between the matrix and serum phases (Guo and Kindstedt, 1995; Guo et al., 1997). As proteolysis occurs, the amount of soluble casein that is in the serum phase increases, accounting for the increase in viscosity of the filler component.

The changes in phase angle ( $\delta$ ) in the cheeses can be seen in Figure 3. Phase angle is a measurement of the difference between the input strain/stress and the response of the material; it shows the degree to which the input and response sinusoidal curves are in or out of phase. For example, in a purely viscous material, when a stress or strain is applied, the fluid's response is very delayed. The input and response curves are completely out of phase, and  $\delta$  is  $90^\circ$ . When a stress or strain is applied to a perfectly elastic material, the material instantly responds in a linear fashion; the input and response curves are perfectly in-phase and therefore,  $\delta$  is  $0^\circ$ . Mathematically, phase angle is a ratio of the energy lost to the energy stored:

$$\tan(\delta) = \frac{G''}{G'}$$

where  $G''$  is the loss modulus and  $G'$  is the storage modulus (Steffe, 1996).

The pattern of response as frequency changes is very similar in all of the cheeses tested; such a pattern shows the time-dependent nature of the stress/strain application in the cheeses and this pattern can be used to differentiate cheeses from other viscoelastic, weak gels. At very low frequencies (0.001 Hz),  $\delta$  is relatively high, showing the dominant effect of the viscous component; the cheeses behave more fluid-like when deformed at slower speeds. As the frequency of strain application increases (0.01 to 1.0 Hz),  $\delta$  levels, showing that the speed has less of an influence on the relative effects of the viscoelastic properties. Finally, at very high frequencies (20 Hz),  $\delta$  is low, showing the dominant effect of the elastic component; the cheeses behave more “solid-like” at such higher speeds.

Changes within cheese variety due to age can also be observed in Figure 3; as Mozzarella and Pizza cheeses aged, the magnitude of  $\delta$  steadily increased. As discussed earlier, the para-casein network that makes up the cheese matrix continues to go through proteolysis and demineralization which makes the network less rigid; a decrease in  $G'$  results, causing an increase in  $\delta$ .

### **Relaxation Properties**

The results from the creep recovery analysis are shown in Figure 4. The varietal differences are apparent; Mozzarella cheese showed the highest overall compliance, Pizza cheese had less overall compliance, and Process cheese showed the lowest compliance. Additionally, as the cheeses aged,  $J_{mx}$  increased showing that the changes in the structure of the cheeses as they age cause the cheese to respond more to the applied force, indicating deformability. Process cheese showed higher crp measurements than the natural cheeses. Percent creep recovery (crp) is a measurement of the resilience of the cheese network. In

recovery tests, the cheese is measured to see how much it returns back to its original shape after being exposed to a constant force; a high crp indicates that the cheese recovered to near its original shape.

The relative influence of the viscous and elastic components during creep recovery testing has been explained using the Burgers model (Steffe, 1996); this model is illustrated in Figure 5. When the initial stress is applied to the cheese, the cause of initial shape change is dominated by the elastic component. As the cheese continues to experience constant stress, the responding deformation is due to both the viscous and elastic components of the material. After a longer period of exposure, the compliance levels off, and long-term viscous flow is observed. Once the stress is removed, again an initial elastic response causes a sharp decrease in compliance. Both viscous and elastic components of the material explain the gradual decrease in compliance as the material is trying to regain its original shape. Finally, viscous flow is observed at longer times until, ideally, the material recovers to near its original shape.

### **Non-linear and Fracture Properties**

The fracture modulus ( $G_f$ ) at varying strain rates for all of the cheeses are given in Figure 6. In all treatments, an increase in  $G_f$  was observed as strain rate increased, confirming the viscoelastic, time-dependent nature of the cheeses. Trends in aging were also seen. Such trends mimicked the trends seen in the elastic modulus. As Pizza cheese aged,  $G_f$  showed a steady decrease at all strain rates tested. In Mozzarella,  $G_f$  sharply decreased from 4 d to 10 d, increased by 17 d and remained steady at 38 d; this trend was seen at the slower strain rates. As discussed previously, these differences may be related to the contribution of the serum phase due to the extent of proteolysis and salt concentration in the 10 d Mozzarella



sample. Additionally, at higher speeds (4.5 rpm), the elastic component dominates over the viscous component in this material, demonstrating the relative importance of the matrix and serum phases in fracture at different rates in these cheeses.

The mechanism by which materials fracture was explained by van Vliet and Walstra (1995). When stresses are applied to a material, the bonds between the structural elements along a specific plane begin to rupture, resulting in fracture of the structure of the material at a much greater scale than the length of the actual structural elements. The material then falls apart due to the lack of structure.

The linear, non-linear, and fracture properties of Mozzarella and Pizza cheeses were compared at two strain rates (0.047 and 0.47 s<sup>-1</sup>) and are shown in Figure 7. Overall, the range of strain characterized using these methods was 0.001 to ~2.0, and stress was characterized from 18 to 40,000 Pa representing three orders of magnitude in both parameters. A gap in the curve was observed between ~0.01 and 0.1 strain. This region could not be measured due to the strain limitations of the equipment used.

The maximum linear viscoelastic strain seen in these cheeses was 0.017 (Figure 7a); these results confirm the weak physical gel classification of these materials. The maximum linear strain for strong physical gels is  $\gamma_{lin} > \sim 0.2$ , whereas weak physical gels show a maximum linear strain up to 1000 times less (Kavanagh and Ross-Murphy, 1998).

Modifications of the rubber elastic theory have been suggested to explain nonlinear viscoelastic behavior for biopolymers. This theory is applicable for materials that exhibit almost complete recovery after being exposed to very large deformations. Such materials consist of polymeric chains that have a high degree of flexibility and are joined into a network structure (Mark, 1983). The structure of casein gels is somewhat different than

polymer systems in that they are formed by the random aggregation of particles into small clusters, which then aggregate further by cluster-cluster aggregation (van Vliet and Walstra, 1995).

### **Relationships Among Rheological Properties**

*Correlation analysis.* Table 1 defines the parameters retained for statistical analysis. Small strain and torsional terms were somewhat positively correlated among each other as is seen in Table 2. As discussed previously,  $G'$  is an indication of the firmness of the network in the material; this relationship shows that materials having a high degree of network firmness could not withstand as much change in shape without fracturing (refer to Figure 7 for fracture strain characterization). However, the lower significance of this correlation ( $P \leq 0.05$ ) indicates that perhaps these parameters were each measuring different properties; since  $G_f$  is measured at fracture, other properties besides the viscoelastic properties contribute to the material's overall response.

Maximum creep compliance ( $J_{mx}$ ) negatively correlated with  $G'$ . A highly rigid network (high  $G'$ ) will deform less than a less rigid network to a given force. Therefore, materials exhibiting a high  $G'$  are likely to comply less. A negative correlation was also observed between  $G_f$  and  $J_{mx}$ . The fracture modulus ( $G_f$ ) is a ratio of stress to strain at fracture; materials having a high  $G_f$  cannot withstand as much strain before fracturing. Conversely, materials showing a high  $J_{mx}$  exhibit a greater degree of straining when compared to materials having a low  $J_{mx}$  when equal stress is applied.

Negative correlations were also seen between  $\lambda_{ret}$  and  $G'$ . Retardation time is an indication of the time needed for a substance to reach full deformation; materials needing

more time to reach full deformation are likely to be less elastic, as shown by a lower  $G'$ . Percent creep recovery is a measurement of the degree of recovery in a given time period; correlations between  $crp$  and  $G'$  as well as between  $crp$  and  $G_f$  were observed. When force is applied to highly rigid materials (high  $G'$ ) within the linear viscoelastic region, the responding strain is small when compared to the response of a material having a more flexible network. Because the amount of total recovery needed to regain the original shape is somewhat small and the network in these materials is relatively less flexible, these materials will return to their original shape more quickly once the force is removed. Material showing high  $J_{mx}$  were negatively correlated with  $crp$ . Materials that comply more when a constant force is added require a greater amount of total recovery in order to regain the original shape once the force is removed, translating into lower  $crp$  in a given time period.

***Principal component analysis.*** Instrumental data was analyzed by principal component analysis. Eigenvectors are nonzero vectors obtained by linearly transforming the original data using some scalar (the eigenvalue); eigenvectors can be used to determine the relative influence of the parameter loadings on the specific principal component. Table 3 outlines the eigenvector loadings for each parameter. Three principal components were able to explain 87.9% of the variation seen in the cheese. Figure 8 shows principal components one (PC1; 61.9% of the total variation) and two (PC2; 14.0% of the total variation). Principal component one distinguished the cheeses by age; as the cheeses aged, their loadings on PC1 decreased. Analysis of the eigenvector loadings revealed that high PC1 values related to high  $G'$  and  $G_f$ , both measurements of the solid-like component of the materials. It also related to lower  $\delta$ ,  $J_{mx}$ , and  $\lambda_{ret}$ . Principal component two related most to the viscous

component of the cheeses ( $G''$ ) and differentiated the natural cheeses from Process cheese with the exceptions of Mozzarella 10 d and Pizza 38d, which loaded similarly to Process cheese.

The instrumental data also differentiated the natural cheeses by type as seen in Figure 9. Instantaneous compliance loaded positively on principal component three (PC3; 12.0% of the total variation). Generally, Pizza cheese loaded higher on PC3 than Mozzarella cheese.

## CONCLUSIONS

Mozzarella, Pizza, and Process cheese all had greater elastic components ( $G'$ ) than viscous components ( $G''$ ) and were highly frequency dependent, indicating the cheeses were viscoelastic, weak gels. Trends in the elastic behavior of these cheeses as they aged were able to differentiate these varieties. The changes in the relative elastic and viscous components of these materials (phase angle) as frequency changed created a unique fingerprint of cheese maturation behavior. Creep recovery analysis showed an age dependent trend; as the cheeses aged, the maximum creep compliance ( $J_{mx}$ ) increased. Fracture characterization differentiated these cheeses based upon variety and age. It is hypothesized that proteolysis due to residual enzyme and brine migration would explain these changes in rheological parameters. Though an understanding of the fundamental rheological properties is important to understand texture generation, to truly understand texture, human perception should be measured. An accompanying manuscript describes the sensory texture characterization of cheeses and relates such information to the rheological characterization described here.

## **ACKNOWLEDGMENTS**

We are grateful for the support from the Southeast Dairy Foods Research Center and Dairy Management, Inc., and would like to thank the Department of Food Science at the University of Wisconsin for collecting and distributing cheeses. We would also like to thank Dr. Marcia Gumpertz, Paige Luck, and Dr. Den Truong for their technical support.

## REFERENCES

- Adda, J., J. C. Gripon and L. Vassal. 1982. The chemistry of flavour and texture generation in cheese. *Food Chem.* 9:115-129.
- Ak, M. M. and S. Gunasekaran. 1997. Anisotropy in tensile properties of Mozzarella cheese. *J. Food Sci.* 62:1031-1033.
- Antoniou, K. D., R. Petridis, S. Raphaelides, Z. Ben Omar, and R. Kesteloot. 2000. Texture assessment of French cheeses. *J. Food Sci.* 65:168-172.
- Bogue, J. C., C. M. Delahunty, M. K. Henry and J. M. Murray. 1999. Market-oriented methodologies to optimize consumer acceptability of Cheddar-type cheeses. *Brit. Food J.* 101:301-316.
- Bowland, E. L. and E. A. Foegeding. 1995. Effects of anions on thermal induced whey protein isolate gels. *Food Hydrocoll.* 9:47-56.
- Bowland, E. L. and E. A. Foegeding. 1999. Factors determining large-strain (fracture) rheological properties of model processed cheese. *J. Dairy Sci.* 82:1851-1859.
- Creamer, L. K. and N. F. Olson. 1982. Rheological evaluation of maturing Cheddar cheese. *J. Food Sci.* 47:631-636.
- de Jong, L. 1976. Protein breakdown in soft cheese and its relation to consistency: 1. proteolysis and consistency of 'Noordhollandse Meshanger' cheese. *Neth. Milk Dairy J.* 30:242-253.
- Diehl, K. C., D. D. Hamann and J. K. Whitfield. 1979. Structural failure in selected raw fruits and vegetables. *J. Texture Stud.* 10:371-400.
- Drake, M. A., P. D. Gerard, V. D. Truong and C. R. Daubert. 1999. Relationship between

- instrumental and sensory measurements of cheese texture. *J. Texture Stud.* 30:451-476.
- Fenelon, M. A. and T. P. Guinee. 2000. Primary proteolysis and textural changes during ripening in Cheddar cheeses manufactured to different fat contents. *Int. Dairy J.* 10:151-158.
- Geurts, T. J., P. Walstra and H. Mulder. 1972. Brine composition and the prevention of the defect 'soft rind' in cheese. *Neth. Milk Dairy J.* 26:168-179.
- Geurts, T. J., P. Walstra and H. Mulder. 1974. Transport of salt and water during salting of cheese: 1. Analysis of the processes involved. *Neth. Milk Dairy J.* 28:102-129.
- Geurts, T. J., P. Walstra and H. Mulder. 1980. Transport of salt and water during salting of cheese: 2. Quantities of salt taken up and of moisture loss. *Neth. Milk Dairy J.* 34:229-254.
- Guinard, J. X. and R. Mazzucchelli. 1996. The sensory perception of texture and mouthfeel. *Trends Food Sci. Technol.* 7:213-219.
- Guinee, T. P., M. A. E. Auty and M. A. Fenelon. 2000. The effect of fat content on the rheology, microstructure and heat-induced functional characteristics of Cheddar cheese. *Int. Dairy J.* 10:277-288.
- Guo, M. R., J. A. Gilmore and P. S. Kindstedt. 1997. Effect of sodium chloride on the serum phase of Mozzarella cheese. *J. Dairy Sci.* 80:3092-3098.
- Guo, M. R. and P. S. Kindstedt. 1995. Age-related changes in the water phase of Mozzarella cheese. *J. Dairy Sci.* 78:2099-2107.
- Hamann, D. D. 1983. Structural failure in solid foods. Pages 351-383 *in Physical Properties of Foods.* M. Peleg and E. B. Bagley, ed. AVI Publishing Company, Inc., Westport,

CT.

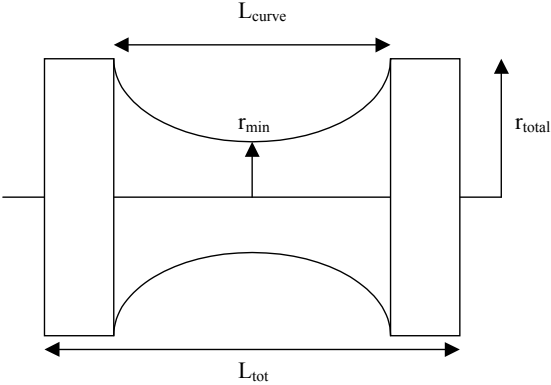
- Hsieh, Y. L., J. J. Yun and M. A. Rao. 1993. Rheological properties of Mozzarella cheese filled with dairy, egg, soy proteins, and gelatin. *J. Food Sci.* 58:1001-1004.
- Kavanagh, G. M., and S. B. Ross-Murphy. 1998. Rheological characterization of polymer gels. *Prog. Polym. Sci.* 23:533-562.
- Konstance, R. P. and V. H. Holsinger. 1992. Development of rheological test methods for cheese. *Food Technol.* 46:105-109.
- Lawrence, R. C., L. K. Creamer and J. Gilles. 1987. Cheese ripening technology- texture development during cheese ripening. *J. Dairy Sci.* 70:1748-1760.
- Lee, C. H., E. M. Imoto and C. Rha. 1978. Evaluation of cheese texture. *J. Food Sci.* 43:1600-1605.
- Ma, L., M. A. Drake, G. V. Barbosa-Canovas and B. G. Swanson. 1996. Viscoelastic properties of reduced-fat and full-fat Cheddar cheeses. *J. Food Sci.* 61:821-823.
- Mark, J. E. 1993. The rubber elastic state. Pages 3-59 *in* Physical Properties of Polymers. J. E. Mark, A. Eisenberg, W. W. Graessley, L. Mandelkern, E. T. Samulski, J. L. Koenig, and G. D. Wignall, ed. American Chemical Society, Washington, D.C.
- McEwan, J. A., J. D. Moore and J. S. Colwill. 1989. The sensory characteristics of Cheddar cheese and their relationship with acceptability. *J. Soc. Dairy Technol.* 42:112-117.
- Nadai, A. 1937. Plastic behavior of metals in the strain-hardening range. Part I. *J. Appl. Physics.* 8:205-213.
- Nolan, E. J., V. H. Holsinger and J. J. Shieh. 1989. Dynamic rheological properties of natural and imitation Mozzarella cheese. *J. Texture Stud.* 20:179-189.
- Prentice, J. H. 1987. Cheese rheology. Pages 299-344 *in* Cheese: Chemistry, Physics, and



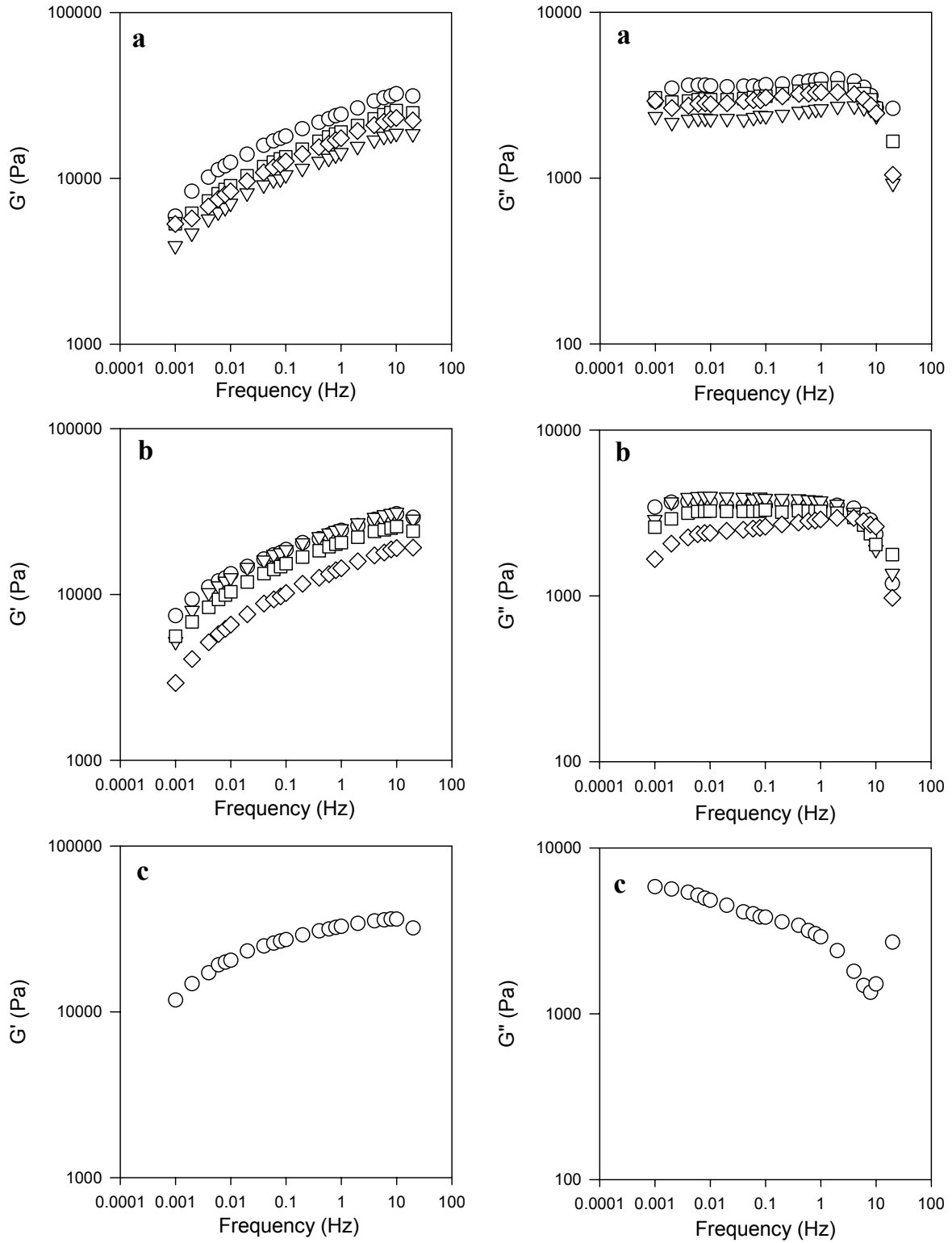
- Microbiology. Vol. 1. P. F. Fox, ed. Elsevier Science Publishing Company, Inc., New York, NY.
- Rosenberg, M., Z. Wang, S. L. Chuang and C. F. Shoemaker. 1995. Viscoelastic property changes in Cheddar cheese during ripening. *J. Food Sci.* 60:640-644.
- Steffe, J. F. 1996. *Rheological Methods in Food Process Engineering*. Freeman Press, East Lansing, MI.
- Subramanian, R. and S. Gunasekaran. 1997a. Small amplitude oscillatory shear studies on Mozzarella cheese: Part I. Region of linear viscoelasticity. *J. Texture Stud.* 28:633-642.
- Subramanian, R. and S. Gunasekaran. 1997b. Small amplitude oscillatory shear studies on Mozzarella cheese: Part II. Relaxation spectrum. *J. Texture Stud.* 28:643-656.
- Taneya, S., T. Izutsu, T. Kimura, T. Shioya, W. Buchheim, P. S. Kindstedt and D. G. Pechak. 1992. Structure and rheology of string cheese. *Food Struct.* 11:61-71.
- Tolstoguzov, V. B. and E. E. Braudo. 1983. Fabricated foodstuffs as multicomponent gels. *J. Texture Stud.* 14:183-212.
- Truong, V. D. and C. R. Daubert. 2000. Comparative study on large strain methods in assessing failure characterization of selected food gels. *J. Texture Stud.* 31:335-353.
- Tunick, M. H. 2000. Rheology of dairy foods that gel, stretch, and fracture. *J. Dairy Sci.* 83:1892-1898.
- Tunick, M. H., K. L. Mackey, P. W. Smith and V. H. Holsinger. 1991. Effects of composition and storage on the texture of Mozzarella cheese. *Neth. Milk Dairy J.* 45:117-125.
- Tunick, M. H., E. L. Malin, P. W. Smith, J. J. Shieh, B. C. Sullivan, K. L. Mackey and V. H.

- Holsinger. 1993. Proteolysis and rheology of low-fat and full-fat Mozzarella cheeses prepared from homogenized milk. *J. Dairy Sci.* 76:3621-3628.
- Tunick, M. H., E. J. Nolan, J. J. Shieh, J. J. Basch, M. P. Thompson, B. E. Maleeff and V. H. Holsinger. 1990. Cheddar and Cheshire cheese rheology. *J. Dairy Sci.* 73:1671-1675.
- van Vliet, T. and P. Walstra. 1983. Rheology of curd and cheese. *Neth. Milk Dairy J.* 37:93-94.
- van Vliet, T. and P. Walstra. 1995. Large deformation and fracture behaviour of gels. *Faraday Disc.* 101:359-370.
- Wendin, K., M. Langton, L. Caous and C. Hall. 2000. Dynamic analyses of sensory and microstructural properties of cream cheese. *Food Chem.* 71:363-378.

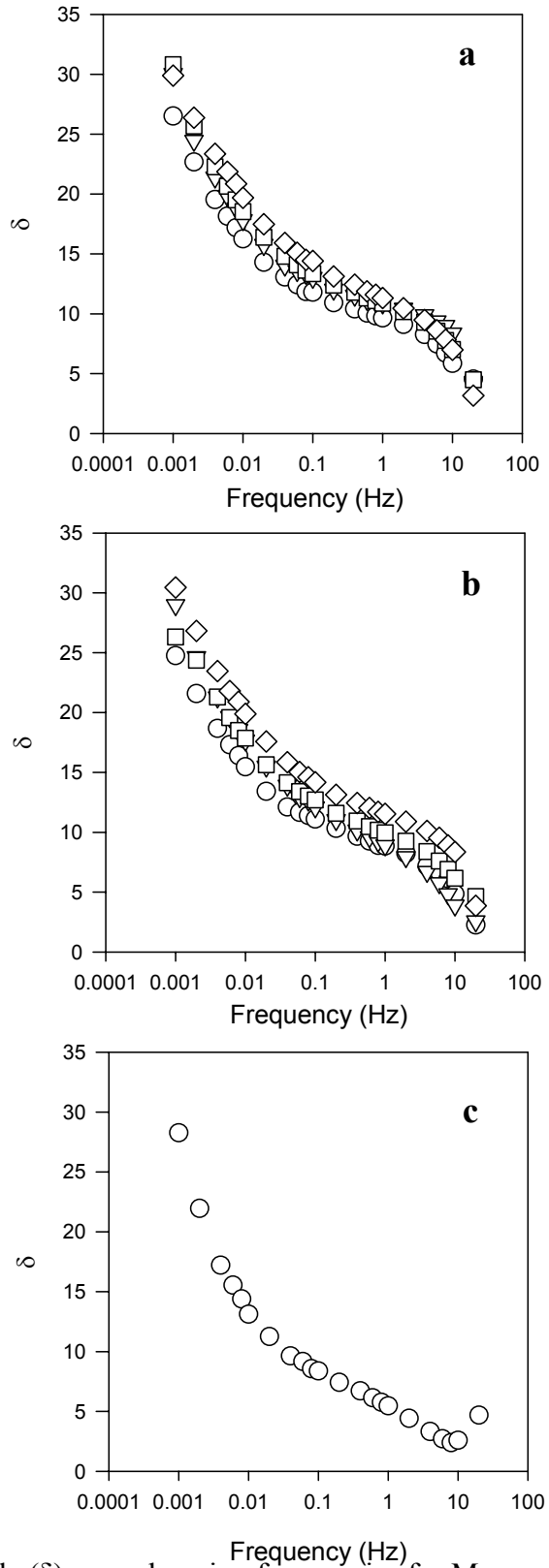
**FIGURES AND TABLES**



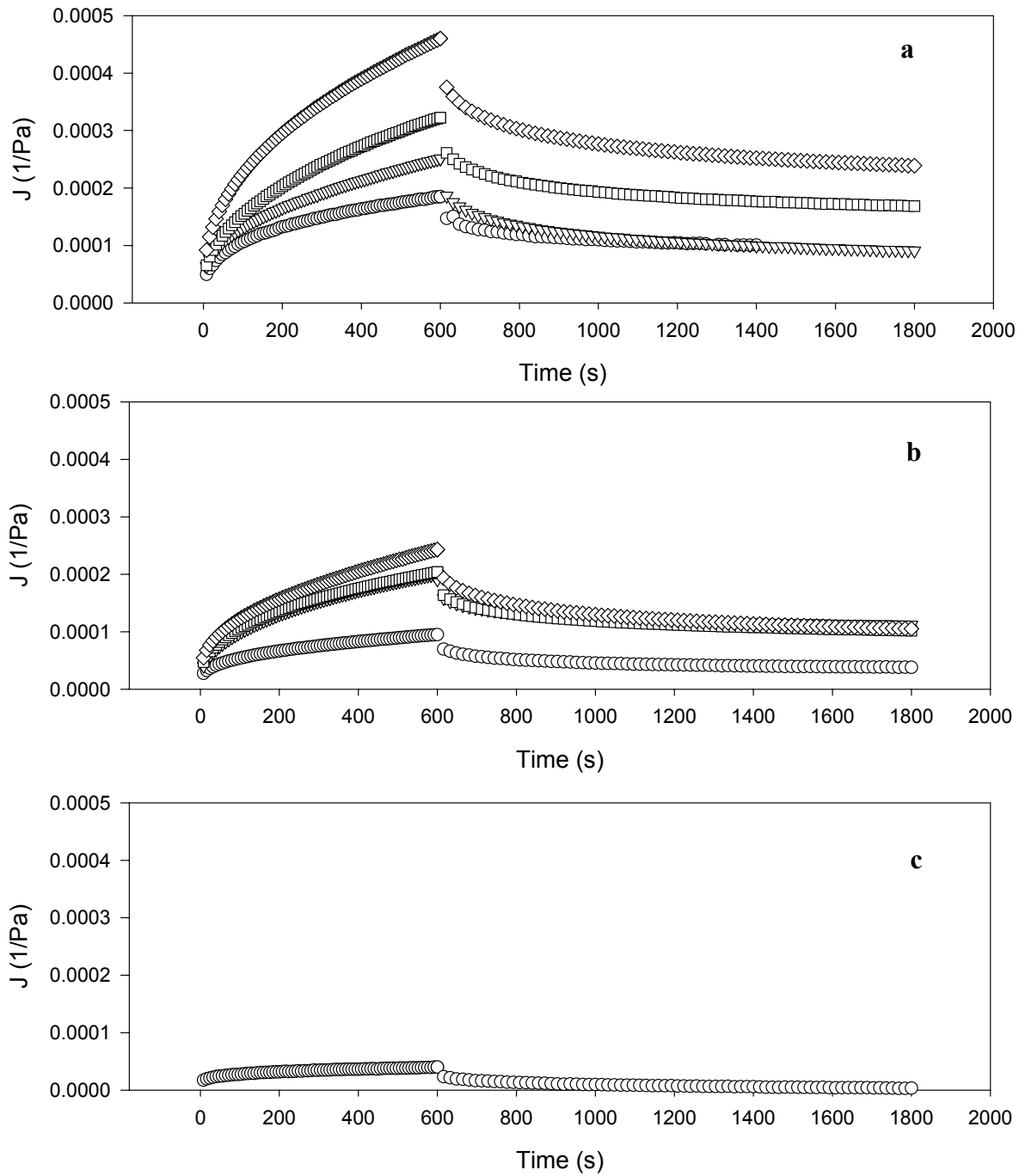
**Figure 1.** Capstan geometry used for torsional testing. Key for parameters: Total cylinder length ( $L_{tot}$ ), Length of capstan curved section ( $L_{curve}$ ), Radius of upper edge of capstan ( $r_{total}$ ), Minimum radius of capstan curved section ( $r_{min}$ ).



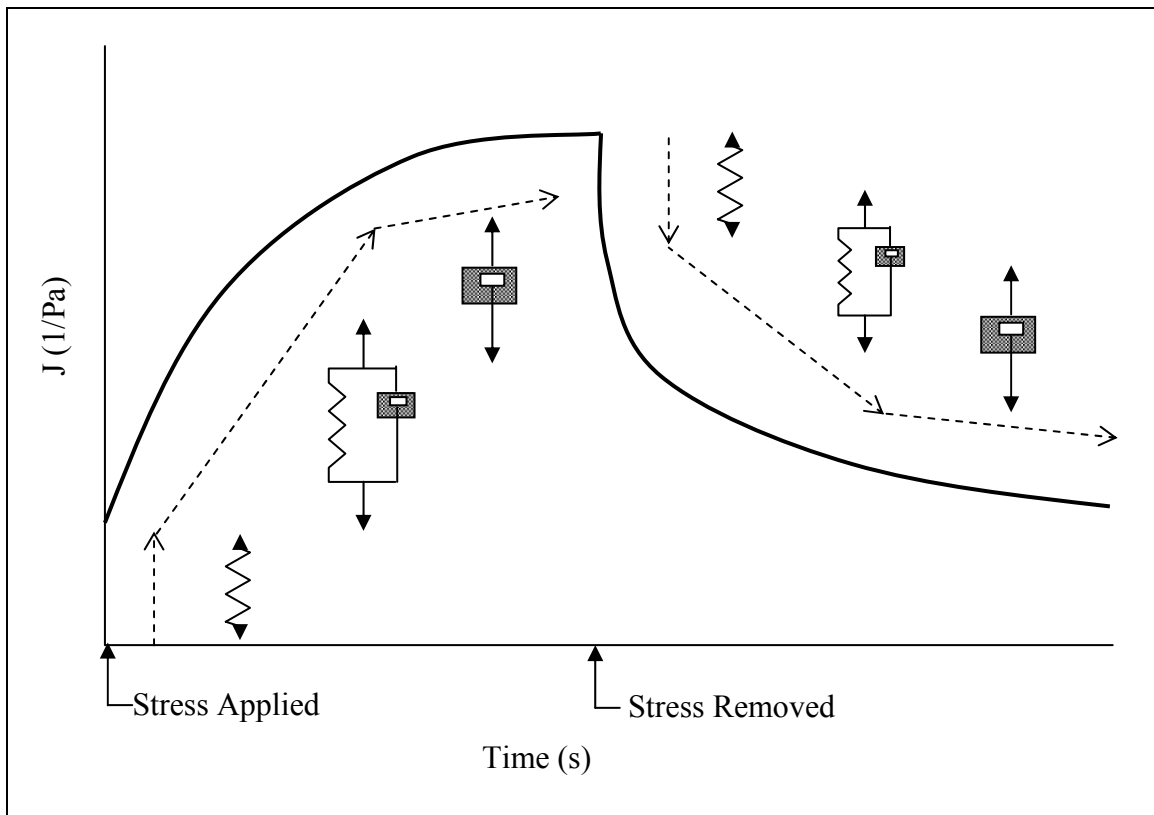
**Figure 2.** Storage modulus ( $G'$ ) and loss modulus ( $G''$ ) over changing frequencies for Mozzarella (a), Pizza (b), and Process (c) cheeses at 4 d (O), 10 d ( $\nabla$ ), 17 d ( $\square$ ) and 38 d ( $\diamond$ ) of age.



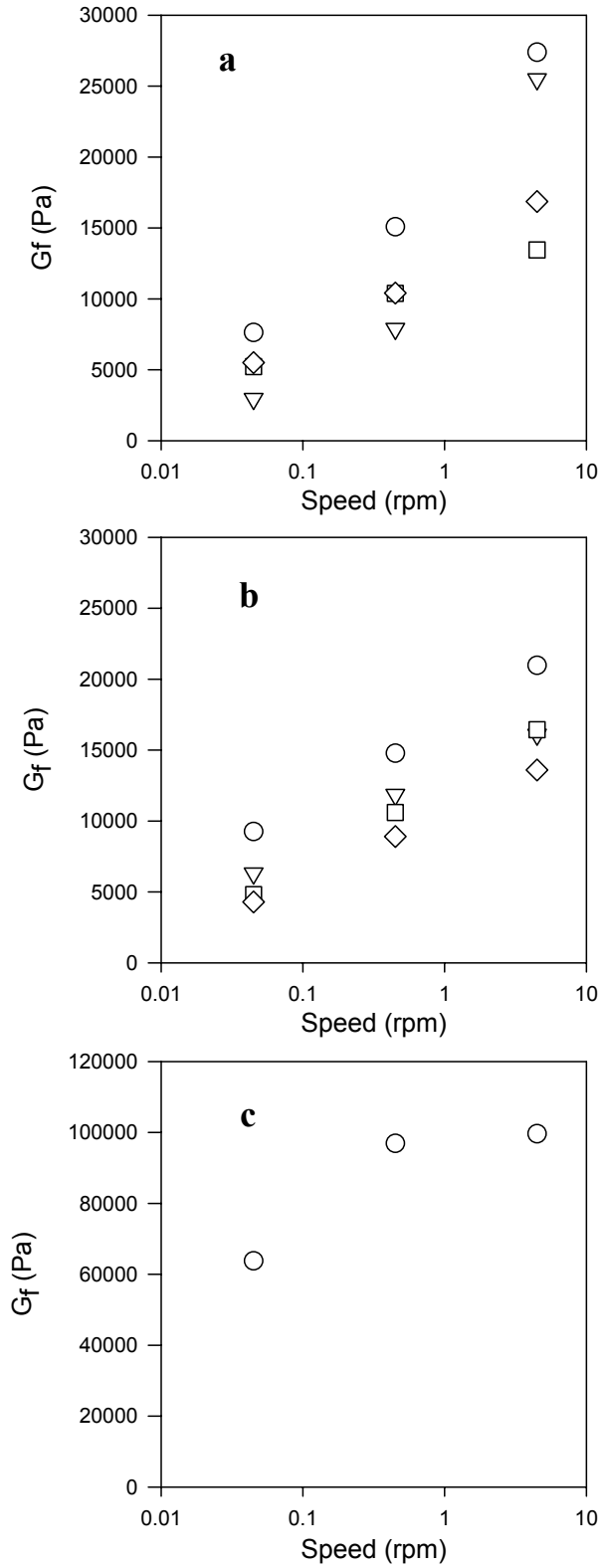
**Figure 3.** Phase angle ( $\delta$ ) over changing frequencies for Mozzarella (a), Pizza (b), and Process (c) cheeses at 4 d (○), 10 d (▽), 17 d (□) and 38 d (◇) of age.



**Figure 4.** Creep recovery curves for Mozzarella (a), Pizza (b), and Process (c) cheeses at 4 d (O), 10 d ( $\nabla$ ), 17 d ( $\square$ ) and 38 d ( $\diamond$ ) of age.

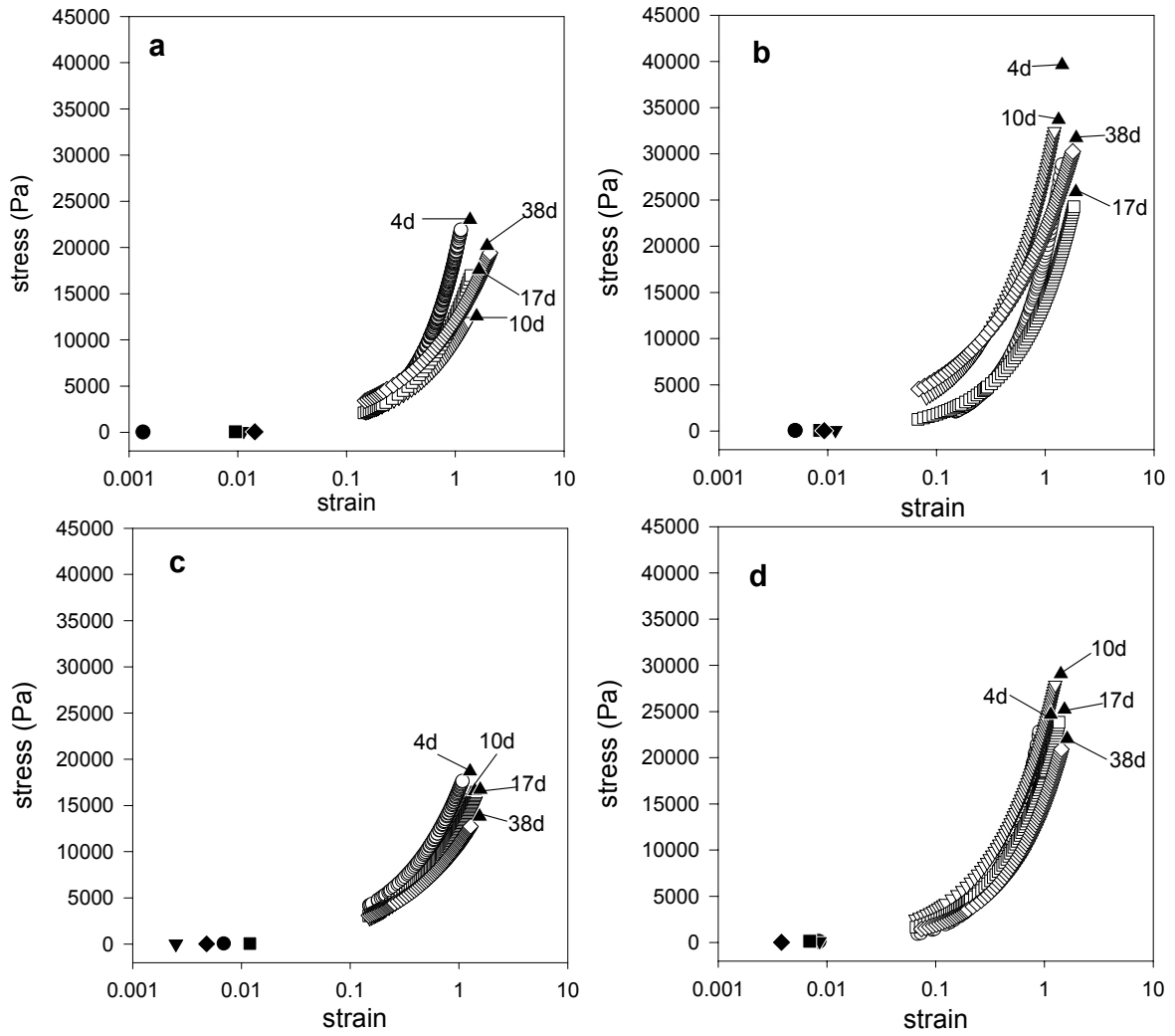


**Figure 5.** Burgers Model showing the relative influence of the elastic (indicated by a spring) and viscous (indicated by a dashpot) components during a typical creep recovery test. Figure is based upon Steffe (1996).

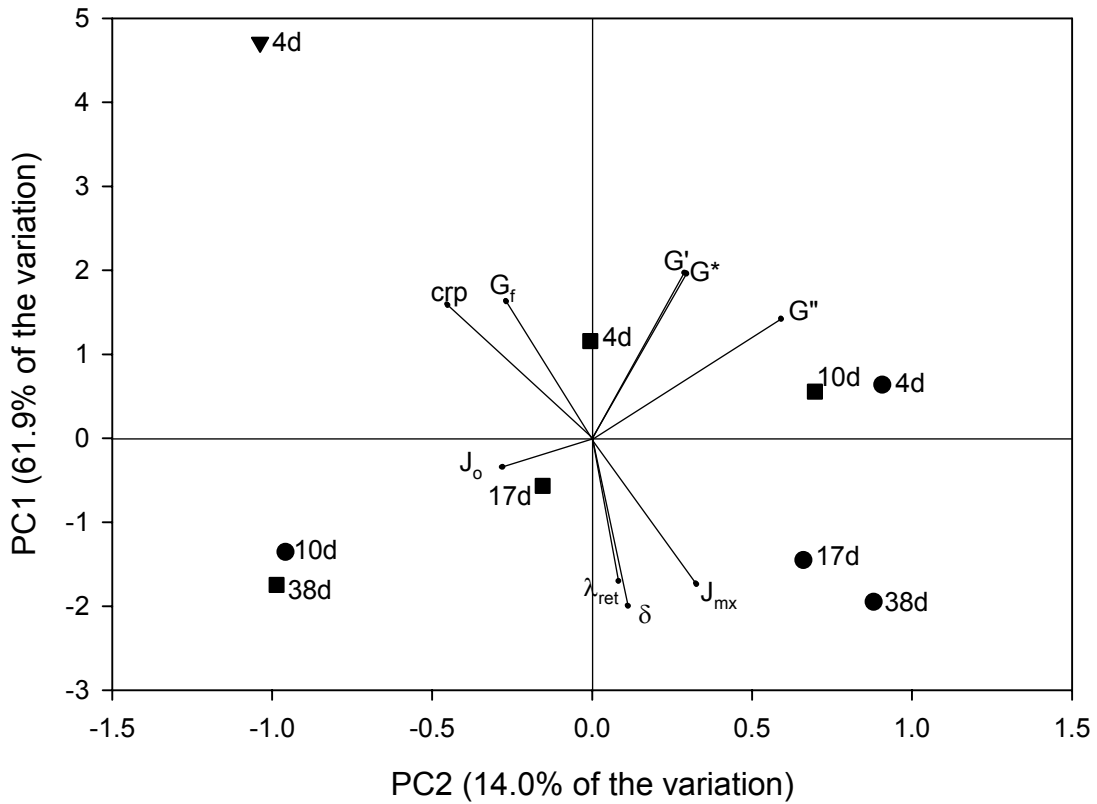


**Figure 6.** Fracture modulus ( $G_f$ ) of Mozzarella (a), Pizza (b), and Process (c) cheeses at 4 d (○), 10 d (▽), 17 d (□) and 38 d (◇) of age.

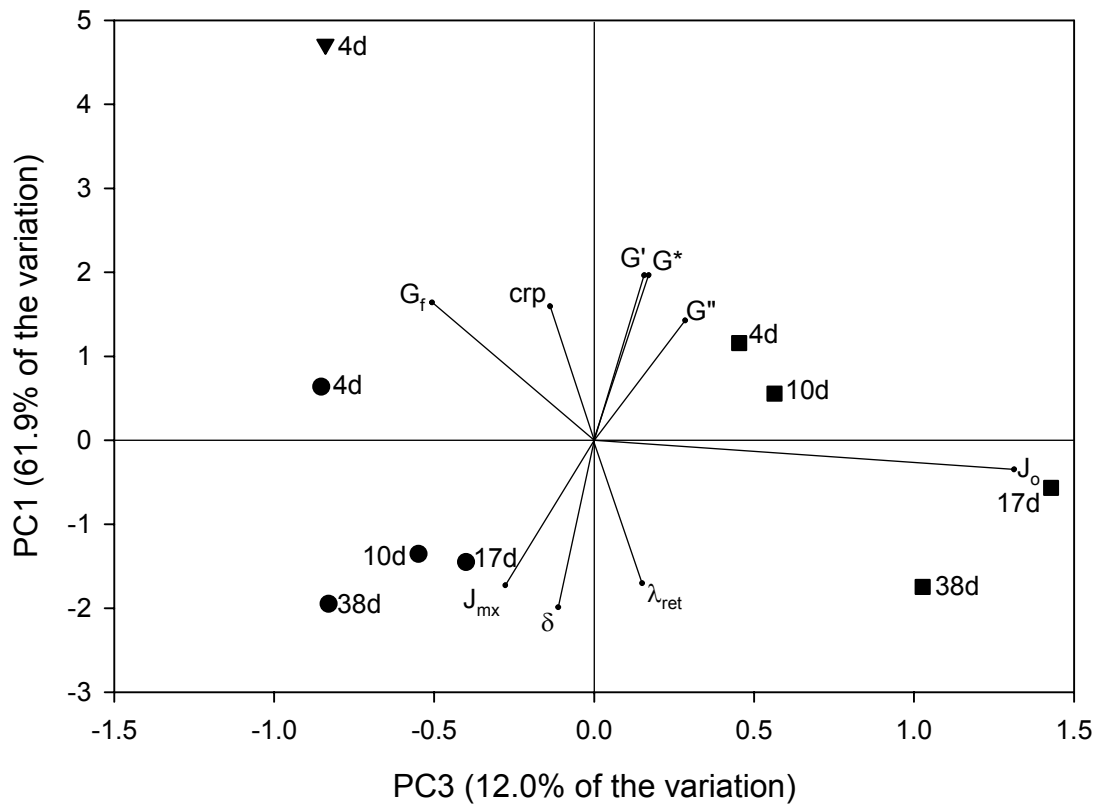




**Figure 7.** Range of rheological properties for Mozzarella cheese at strain rates of 0.047 (a) and 0.47 (b) s<sup>-1</sup> and Pizza cheese at strain rates of 0.047 (c) and 0.47 (d) s<sup>-1</sup>. Closed shapes represent the strain limit (i.e. endpoint of linear viscoelastic region) from small strain tests at 4 d (●), 10 d (▼), 17 d (■) and 38 d (◆) of age. Open shapes represent non-linear characteristics from torsional tests at 4 d (○), 10 d (▽), 17 d (□) and 38 d (◇) of age. Fracture characteristics are also given (▲) (ages are given beside symbol).



**Figure 8.** Principal component analysis biplot of instrumental parameters used to differentiate Mozzarella (●), Pizza (■), and Process (▼) cheeses by age (indicated by numbers beside symbol). Key for instrumental parameters: Complex modulus ( $G^*$ ), Storage modulus ( $G'$ ), Loss modulus ( $G''$ ), Phase angle ( $\delta$ ), Fracture modulus ( $G_f$ ), Initial compliance ( $J_0$ ), Maximum compliance ( $J_{mx}$ ), Percent creep recovery ( $crp$ ), Retardation time ( $\lambda_{ret}$ ).



**Figure 9.** Principal component analysis biplot of instrumental parameters used to differentiate Mozzarella (●), Pizza (■), and Process (▼) cheeses by age (indicated by numbers beside symbol). Key for instrumental parameters: Complex modulus ( $G^*$ ), Storage modulus ( $G'$ ), Loss modulus ( $G''$ ), Phase angle ( $\delta$ ), Fracture modulus ( $G_f$ ), Initial compliance ( $J_0$ ), Maximum compliance ( $J_{mx}$ ), Percent creep recovery ( $crp$ ), Retardation time ( $\lambda_{ret}$ ).

**Table 1.** Definitions of parameters used for statistical analysis.

Symbol	Definition
$G^*$	Complex modulus- taken from small strain frequency sweep tests at 0.1 Hz
$G'$	Storage modulus- taken from small strain frequency sweep tests at 0.1 Hz
$G''$	Loss modulus- taken from small strain frequency sweep tests at 0.1 Hz
$\delta$	Phase angle- taken from small strain frequency sweep tests at 0.1 Hz
$G_f$	Fracture modulus- taken from large strain torsional tests at 4.5 rpm
$J_o$	Instantaneous compliance- compliance at time 0 s from creep recovery tests
$J_{mx}$	Maximum compliance- from creep recovery tests; maximum compliance value just before stress is released
crp	Percent creep recovery- from creep recovery tests; relative amount of recovery after the material is subjected to a constant stress over a given time period
$\lambda_{ret}$	Retardation time- time for material to reach 1-1/e (63.2%) of the delayed strain (from creep recovery tests)

**Table 2.** Correlation analysis of instrumental parameters for assessment of cheese texture. Key for instrumental parameters: Complex modulus ( $G^*$ ), Storage modulus ( $G'$ ), Loss modulus ( $G''$ ), Phase angle ( $\delta$ ), Fracture modulus ( $G_f$ ), Initial compliance ( $J_o$ ), Maximum compliance ( $J_{mx}$ ), Retardation time ( $\lambda_{ret}$ ), Percent creep recovery (crp).

	$G^*$	$G'$	$G''$	$\delta$	$G_f$	$J_o$	$J_{mx}$	$\lambda_{ret}$	crp
$G^*$	1.000	<b>0.999</b> <sup>***</sup>	<b>0.858</b> <sup>***</sup>	<b>-0.845</b> <sup>***</sup>	<b>0.599</b> <sup>*</sup>	-0.144	<b>-0.621</b> <sup>*</sup>	<b>-0.678</b> <sup>**</sup>	<b>0.543</b> <sup>*</sup>
$G'$		1.000	<b>0.853</b> <sup>***</sup>	<b>-0.847</b> <sup>***</sup>	<b>0.596</b> <sup>*</sup>	-0.134	<b>-0.623</b> <sup>*</sup>	<b>-0.672</b> <sup>**</sup>	<b>0.552</b> <sup>*</sup>
$G''$			1.000	<b>-0.507</b> <sup>*</sup>	0.303	-0.135	-0.365	-0.379	0.214
$\delta$				1.000	<b>-0.675</b> <sup>**</sup>	0.065	<b>0.831</b> <sup>***</sup>	<b>0.787</b> <sup>***</sup>	<b>-0.707</b> <sup>**</sup>
$G_f$					1.000	-0.275	<b>-0.573</b> <sup>*</sup>	<b>-0.581</b> <sup>*</sup>	<b>0.806</b> <sup>***</sup>
$J_o$						1.000	-0.087	0.197	-0.039
$J_{mx}$							1.000	<b>0.689</b> <sup>**</sup>	<b>-0.731</b> <sup>**</sup>
$\lambda_{ret}$								1.000	<b>-0.499</b> <sup>*</sup>
crp									1.000

\* significant at  $P \leq 0.05$

\*\* significant at  $P \leq 0.005$

\*\*\* significant at  $P \leq 0.0001$

**Table 3.** Eigenvector loadings for principal component analysis of instrumental parameters for assessment of cheese texture. Key for instrumental parameters: Complex modulus ( $G^*$ ), Storage modulus ( $G'$ ), Loss modulus ( $G''$ ), Phase angle ( $\delta$ ), Fracture modulus ( $G_f$ ), Initial compliance ( $J_o$ ), Maximum compliance ( $J_{mx}$ ), Retardation time ( $\lambda_{ret}$ ), Percent creep recovery (crp), Principal component one (PC1), Principal component two (PC2), and Principal component three (PC3). Bolded numbers represent primary loadings.

Parameter	PC 1	PC 2	PC 3
$G^*$	<b>0.394</b>	0.294	0.105
$G'$	<b>0.394</b>	0.287	0.114
$G''$	0.286	<b>0.589</b>	0.190
$\delta$	<b>-0.398</b>	0.110	-0.076
$G_f$	0.328	-0.270	<b>-0.338</b>
$J_o$	-0.069	-0.284	<b>0.876</b>
$J_{mx}$	<b>-0.345</b>	0.323	-0.184
$\lambda_{ret}$	<b>-0.340</b>	0.082	0.100
crp	0.320	<b>-0.455</b>	-0.092

## **CHEESE TEXTURE CHARACTERIZATION**

**J. A. Brown<sup>\*</sup>, E. A. Foegeding<sup>\*</sup>, M. A. Drake<sup>\*</sup>, C. R. Daubert<sup>\*</sup>, and M. Gumpertz<sup>†</sup>**

<sup>\*</sup> Department of Food Science and

<sup>†</sup> Department of Statistics

North Carolina State University

## ABSTRACT

The physical properties and perceptual texture of young cheeses were defined in order to understand what regulates cheese texture. Mozzarella and Pizza cheeses were tested at 4, 10, 17, and 38 d of age; Process cheese was tested at 4 d of age. Rheological methods were employed to determine the viscoelastic and fracture properties of the cheeses. A trained sensory panel developed appropriate descriptive language and product-specific reference scales to evaluate cheese texture. Sensorial and rheological methods differentiated the cheese varieties, and patterns of change in these properties as the cheeses aged were seen. Correlations between the sensory and rheological methods were observed. Principal component analysis on just the sensory characterization revealed that three principal components explained 96.1% of the total variation in the cheeses; such analysis was able to differentiate the cheeses by variety and order the cheeses by age. Principal component analysis on the instrumental and sensory parameters explained 82.1% of the total variation (three principal components) and differentiated the cheeses by variety and age; this analysis revealed three groupings of parameters: group one explained the rigidity of the samples, group two explained the resiliency of the cheeses, and group three explained chewdown texture. Defining the small and large strain rheological properties and the sensory perception of maturing cheeses can help the cheese industry to better understand the transitions occurring during the early stages of aging. Such information might aid in customizing cheese texture.

**(Key Words:** cheese, texture, sensory, rheology)

**Abbreviation key:**  $G^*$ = Complex modulus,  $G'$ = Storage modulus,  $G''$ = Loss modulus,  $\delta$ = Phase angle,  $J$ = Compliance,  $\sigma$ = Stress,  $\gamma$ = Strain,  $\lambda_{ret}$ = Retardation time,  $J_0$ = Instantaneous



compliance,  $J_{mx}$ = Maximum compliance,  $crp$ = Percent creep recovery,  $(J_r)_{eq}$ = Equilibrium relaxation compliance,  $L_{tot}$ = Total cylinder length,  $L_{curve}$ = Length of capstan curved section,  $r_{total}$ = Radius of upper edge of capstan,  $r_{min}$ = Minimum radius of capstan curved section,  $\sigma_t$ = True shear stress,  $\gamma_{t-true}$ = True shear strain,  $K$ = Shape factor constant,  $M$ = Torque,  $\phi_s$ = Angular deformation of capstan curved section,  $Q$ = Curvature section constant,  $G_f$ = Shear fracture modulus,  $hfm$ = Hand firmness,  $hsp$ = Hand springiness,  $hrc$ = Hand rate of recovery,  $ffm$ = First bite firmness,  $ffr$ = First bite fracturability,  $cbr$ = Chewdown degree of breakdown,  $cco$ = Chewdown cohesiveness,  $cad$ = Chewdown adhesiveness,  $csm$ = Chewdown smoothness,  $rsm$ = Residual smoothness,  $PC1$ = Principal component one,  $PC2$ = Principal component two,  $PC3$ = Principal component three

## INTRODUCTION

All over the world, cheese is found on the plates of most meals consumed each day. It is considered an ideal food due to its high nutrition, convenience, variety, availability, and good taste (Bogue et al., 1999). With its widespread popularity and production, the consumers' palate is becoming more discriminating when determining cheese purchases. In order for cheese makers to remain competitive, they must produce high quality cheeses that meet the consumers' expectations.

Texture is an important expectation used to differentiate many cheese varieties (Wendin et al., 2000). Appropriate cheese texture is considered by the consumer to be a determinant of overall quality and preference (Lee et al., 1978; Adda et al., 1982; McEwan et al., 1989). When the perceived texture during mastication does not match the visible or descriptive expectation, consumer preference and acceptability will be low (Guinard and

Mazzucchelli, 1996).

Texture encompasses two fundamental principles: it pertains to the actual, physical structure of the material, and it is a perception of the visual and tactile elements of the material (Szczesniak, 1963). Christensen (1984) noted that both of these properties (physical and perceptual) are derived from the basic elements of the food structure and the sensory systems, implying that understanding fundamental principles about both the physical structure of the material and the human sensory processes utilized during mastication is necessary in order to draw conclusions about a material's texture. Therefore, to fully define a food's texture, one must measure both the physical properties of the food and the perceptual properties of the food.

The structure of cheese fits a filled gel model. A filled gel is described as a multicomponent material in which one of the components is a gelling agent that forms a continuous network and the other component(s) acts to fill in the network (Tolstoguzov and Braudo, 1983). Cheese is composed of a continuous, three-dimensional network of primarily casein. When this protein network forms during gelation, it entraps fat globules and moisture contained in the milk, forming the filler component (Prentice, 1987). It is thought that since the fat is highly hydrophobic, water in this system can associate with the protein. It exists in both free and bound states (Prentice, 1972).

Rheology is the study of the deformation and flow of materials (Steffe, 1996). Such methods measure mechanical properties of materials under various conditions, namely at various stresses and strains. Two classes of rheological tests have been identified: small strain tests and large strain tests. Small strain rheological methods are implemented within the linear viscoelastic region of the material and therefore, are designed to be non-destructive

to the basic structure of the material (van Vliet and Walstra, 1983). By performing such tests within the linear viscoelastic region, the elastic and loss moduli become only a function of time and not a function of the magnitude of the stress or strain applied (Tunick, 2000). Cheese is a time-dependent material in that the response of the cheese to an applied stress depends upon the speed in which the stress is applied making such methods appropriate. These methods are used to define both the elastic and the viscous nature of cheese. Results from viscoelastic characterization have provided a way to characterize and differentiate cheese varieties (Nolan et al., 1989; Tunick et al., 1990), have shown the impact of changes in cheese formulation and processing (Rosenberg et al., 1995; Ma et al., 1996; Subramanian and Gunasekaran, 1997a; 1997b), and have aided in understanding mechanisms of typical end-use functions, such as melt (Guinee et al., 2000). Large strain rheological methods occur outside of the linear viscoelastic region and characterize the non-linear and fracture properties of the material. These types of methods correlate well with sensory properties since mastication is a large strain action; results from such studies have been used to show the impact of changes in formulation and processing practices on the texture of cheese (Tunick et al., 1991; Hsieh et al., 1993; Tunick et al., 1993; Bowland and Foegeding, 1999; Fenelon and Guinee, 2000). Such methods have also been used to characterize certain varieties of cheese (Ak and Gunasekaran, 1997).

Though rheological methods do provide an adequate characterization of the physical properties of cheese, using only these methods to understand cheese texture is insufficient. The rheological depiction must be paired with a human psychophysical interpretation of the tactile and visual perceptions that occur when consuming cheese in order to completely understand what causes differences in cheese texture. Quantification of human texture

perception is difficult because of the many sensory systems involved. The tongue, teeth, and tissues lining the oral cavity all give clues of the textural elements of the material. Feedback associated from the movement of oral muscles as the food is being chewed also differentiates a material's texture. Even sounds created by the manipulation of the material aid in determining texture (Christensen, 1984).

Szczesniak (1963) was a pioneer in developing a standard classification system for qualifying textural perception. In supplemental studies, standard reference scales were developed as a means to quantify the textures mentioned in the standard texture classification system (Szczeniak et al., 1963). Another group dissected texture perception into three phases (first bite, masticatory, and residual) and clarified what textures are perceived at each phase (Brandt et al., 1963). Using this information, the scientists were able to develop the sensory texture profile method which assessed the entire textural image from first bite through the completed mastication.

Since then, many variations on the standard reference scale have been developed as well as methods by which textural lexicons can be generated (Munoz and Civille, 1998). Methods to improve evaluation techniques have also been explored. Drake et al. (1999a) showed that both hand and mouth evaluation of similarly differentiated the texture of a variety of cheeses. Sensory descriptive methods have been used to determine what characteristics of cheeses are most desired by consumers and to differentiate different cheese varieties (McEwan et al., 1989; Bogue et al., 1999; Murray and Delahunty, 2000).

Due to the extensive amount of resources that must be invested in generating and validating sensory data, attempts have been made to discover instrumental methods which would mimic human sensory perception, particularly the large strain compressions that occur

during biting (Friedman et al., 1963). Though such instrumentation is relatively unbiased in measuring the physical condition of a sample, some limitations have been noted using this approach. While instrumental mechanical measurements have correlated well with the mechanical sensory perceptions, such as hardness and springiness, instrumentation cannot accurately profile the entire sensory textural experience (Lee et al., 1978; Chen et al., 1979; Casiraghi et al., 1989; Jack et al., 1993). Research has been done to correlate sensory perception with certain fundamental properties of the physical structure of cheese using small strain rheological testing. Though combinations of these fundamental properties were able to predict certain textural sensations, it was concluded that overall, empirical measurements were better able to predict the sensory attributes (Drake et al., 1999b).

There are many complications associated with relating empirical rheological measurements and sensory data. First, mimicking the human sensory process is very difficult. Empirical methods do not accurately imitate physical changes that occur in the mouth due to saliva interactions, phase changes, and temperature changes. Second, mastication is a dynamic process (Christensen, 1984; Wilkinson et al., 2000). Traditional rheological tests measure only a 'single' event: the forces and deformations associated with 'first' and sometimes 'second' bite during consumption. This represents only 2-10% of the total normal mastication time (Bourne, 1975). However, mastication is a series of simultaneous, sequential tests. The human takes one bite and breaks the food into two pieces, creating two 'new samples' that are smaller in size; these samples are then broken into smaller pieces creating more new samples with each bite. Third, human individual oral processes are highly idiosyncratic; instrumental methods cannot mimic each person's particular chewing patterns (Wilkinson et al., 2000). Finally, empirical methods do not

supply any additional information about the material's texture that cannot be derived from sensory testing. Fundamental rheological properties, however, could provide information about physical and chemical structure which could relate to known models of behavior.

Exploration of the small strain region of cheeses would prove valuable since such measurements deduce the physical and chemical properties of the material, relating to fundamental information. Such information may give clues as to what determines textural perception. Additionally, little work has been done to characterize the entire strain region from a physical and perceptual standpoint in young cheeses, in order to create a comprehensive picture of the textural transitions that occur during the early stages of cheese maturation. The objectives of this research were threefold: first, to define the fundamental properties of young cheeses and to see how such properties change as the cheeses age, including linear viscoelastic properties and fracture properties; second, to determine the human perception of the texture of such cheeses over the entire range of mastication; and third, to relate these physical and perceptual definitions in order to better understand what governs texture in cheeses.

## **MATERIALS AND METHODS**

### **Material Description**

Mozzarella and Pizza cheeses were tested at 4, 10, 17, and 38 d of age; High melt process cheese (referred to as Process cheese) was tested at 4 d of age. This testing scheme was repeated. Mozzarella cheese was manufactured by Alto Dairy Cooperative (Waupun, WI), Pizza cheese was made by Meister Cheese Company (Muscodia, WI), and Process cheese was produced by Kraft (Glenview, IL). On two different occasions, cheeses were

collected immediately following manufacture and shipped to North Carolina State University using temperature-controlled packaging material to ensure that the cheeses remained at appropriate temperatures during shipping; all aging occurred at North Carolina State University. Cheeses were stored at 4°C in 4.5 kg blocks in Cryovac B series, vacuum-sealed bags. Approximately 3-cm of the outer rind of the cheeses was discarded immediately prior to sample preparation. The cheeses were allowed to temper to room temperature before testing.

### **Rheological Analysis**

*Small strain analysis.* Dynamic oscillatory measurements were done using a Bohlin VOR controlled strain rheometer (Bohlin Reologi AB, Lund, Sweden) fitted with 30-mm diameter serrated parallel plates and an 11.085-g-cm torque bar. The use of the serrated plates prevented specimen slippage. Cheeses were sliced to a 2-mm thickness and placed onto the lower plate surface; the upper plate was then lowered so that a 2-mm gap existed between the upper and lower plates. The edges of the samples were cut to fit the exact dimensions of the plates. A thin film of synthetic lubricant (Superlube- Loctite Corporation, Rocky Hill, CT) was applied to the exposed edges of the sample to prevent moisture loss. A circulating water bath ensured that the sample temperature was maintained at 25° C.

Values of the complex modulus ( $G^*$ ), the storage modulus ( $G'$ ), the loss modulus ( $G''$ ), and the phase angle ( $\delta$ ) were obtained under two conditions. First, strain sweeps were run on all samples in order to determine the linear viscoelastic region. In these tests, the frequency of the oscillation was held constant and the amount of strain was varied over a specified range. Strain sweeps were at frequencies of 0.001, 0.01, 0.1, and 1.0 Hz over a strain range of  $1.5 \times 10^{-4}$  to  $1.5 \times 10^{-1}$ . Second, frequency sweeps were used to characterize

changes in the viscous and elastic behavior with changes in the rate of strain application. In such tests, the amount of strain is held constant while the frequency (or rate of strain application) changes. Three frequency sweeps were completed on each treatment replication at a constant strain within the linear viscoelastic region (as determined by the strain sweep) starting at 0.001 Hz continuing systematically up to 20 Hz then returning step-wise to 0.001Hz. Measurements of  $G^*$ ,  $G'$ ,  $G''$ , and  $\delta$  at 0.1 Hz were used for statistical analysis since it has been shown that this frequency falls within a known range of frequencies that occur during chewing (Sharma and Sherman, 1973).

In creep recovery tests, the material is subjected to a constant stress for a given time period, and the corresponding strain is measured. Then, the stress is removed, and again, the corresponding strain is measured for a given time period as the material attempts to return to its original shape. Mathematically, compliance ( $J$ ) is represented by

$$J = \frac{\gamma}{\sigma_{\text{constant}}}$$

where  $\sigma_{\text{constant}}$  is the constant stress applied and  $\gamma$  is the resulting strain. Such tests were done using a Stress Tech controlled stress rheometer (ATS Rheosystems, Bordentown, NJ) fitted with 20-mm diameter, smooth parallel plates. Samples were sliced into 2-mm thick slices and glued to the bottom plate with a dot of cyanoacrylate glue (Loctite 100- Loctite Corporation, Rocky Hill, CT). A second dot of the same glue was placed on the top of the sample and the upper plate was lowered to come into contact with the sample. The sample was then trimmed to fit the plate size, and a thin film of synthetic lubricant (Superlube- Loctite Corporation, Rocky Hill, CT) was applied to prevent moisture loss. All tests were executed at a stress within the linear viscoelastic region as determined by stress sweeps



(stress sweeps were run at 1.0 Hz from 0 to 500 Pa in order to confirm the linear viscoelastic region determined previously using the controlled strain rheometer). The creep portion of each test consisted of a stress application for 600 s; the stress was then removed and measurements of recovery were made for an additional 1200 s. Strain rates used in the creep recovery tests corresponded to a range of  $1.7 \cdot 10^{-5}$  to  $1.0 \cdot 10^{-3} \text{ s}^{-1}$ . Temperature was maintained at 25° C through the use of an induction heating device. Three creep recovery tests were completed on each treatment replication.

Retardation time ( $\lambda_{ret}$ ) gives an indication of the time needed for a substance to reach full deformation and is determined by the time required for the delayed strain to reach 1-1/e (63.2%) of its final value (Steffe, 1996). Instantaneous compliance ( $J_0$ ) is the compliance at time zero and was determined through extrapolation of the creep curve to time zero.

Maximum compliance ( $J_{mx}$ ) is the peak compliance reached by the material generally just before the constant stress is removed. Percent creep recovery (crp) has been shown to be a indication of the degree of elasticity in the material and was calculated using the following relationship (Drake et al., 1999b):

$$crp = \frac{J_{mx} - (J_r)_{eq}}{J_{mx}} * 100$$

where  $J_{mx}$  is the maximum creep compliance and  $(J_r)_{eq}$  is the equilibrium relaxation compliance.

**Large strain analysis.** Torsional methods were used to determine the fracture properties of the cheeses. Cylinders of cheese were formed using a 19-mm internal diameter cork borer. The cylinders were cut to a length of 28.7-mm, and plastic disks (Gel Consultants, Raleigh, NC) were glued to the ends of the cylinder using cyanoacrylate glue

(Loctite 100- Loctite Corporation, Rocky Hill, CT) to enable the samples to be mounted to the grinding and twisting apparatuses. The cylinders were formed into a capstan shape having a minimum diameter of 10-mm using a precision grinding machine (Gel Consultants, Raleigh, NC). Measurements of the total cylinder length ( $L_{tot}$ ), length of curved section ( $L_{curve}$ ), top cylinder radius ( $r_{total}$ ), and minimum radius ( $r_{min}$ ) were taken in order to calculate the geometry of the curved section. Figure 1 illustrates the capstan geometry. Samples were twisted using a Haake 550 viscotester (Gebruder Haake GmbH, Karlsruhe, Germany) fitted with a fabricated apparatus (Truong and Daubert, 2000) that would enable torsional measurement. The capstans were twisted at 4.5 rpm and three replications of each treatment replication were made.

True shear stress ( $\sigma_t$ ) and true shear strain ( $\gamma_{t-true}$ ) were calculated using the following relationships (Nadai, 1937; Diehl et al., 1979; Hamann, 1983):

$$\sigma_t = \frac{2KM}{\pi r_{min}^3}$$

$$\gamma_t = \frac{2K\phi_s}{\pi r_{min}^3 Q}$$

$$\gamma_{t-true} = \ln \left[ 1 + \frac{\gamma_t^2}{2} + \gamma_t \left( 1 + \frac{\gamma_t^2}{4} \right)^{1/2} \right]$$

where  $r_{min}$  is the minimum capstan radius, K is the shape factor constant (equal to 1.08), M is the torque (N m),  $\phi_s$  is the angular deformation of the curved section, and Q is the curvature section constant ( equal to  $8.45 * 10^{-6} \text{ m}^{-3}$ ).

From these equations, the shear fracture modulus ( $G_f$ ) was calculated according to the following equation (Bowland and Foegeding, 1995):

$$G_f = \frac{\sigma_t}{\gamma_{t-true}}$$

where  $\sigma_t$  is the true shear stress and  $\gamma_{t-true}$  is the true shear strain.

### **Sensory Analysis**

Descriptive sensory analysis techniques were used to describe the human textural perception of the cheeses. A panel of 15 people received approximately 10 hours of training encompassing evaluation techniques, texture term definitions, and use of reference scales. Cheeses were evaluated using hand, mouth, and residual techniques. The terms used to define texture are outlined in Table 1 (Drake et al., 1999a; Gwartney et al., 2002); abbreviations for each term are also given. The terms were evaluated in the order listed in the table. The panel developed a 15-point product-specific reference scale for each term, with a score of 15 indicating that the sample was high in the attribute (see Table 1). During training, the panel was presented cheeses having textural extremes for each term representing the anchors of each scale. The panel was then presented with more common, well-known cheeses, and through panel consensus, scores were assigned to these cheeses, thereby completing the reference scales. Through training and group discussion, panel variability was minimized.

At each sample evaluation session, three to six cheese samples were evaluated. Each cheese sample was cut into 1.27-cm<sup>3</sup> cubes and each panelist was given four cubes of cheese per sample. The samples were presented at room temperature in 2-oz plastic sample cups sealed with plastic lids (Sweetheart Cup Company Inc., Owings Mills, MD) to deter moisture loss, and samples were identified by a random 3-digit numerical code. The testing occurred in individual booths under normal lighting conditions. At each session, panelists were given

appropriate references, prepared in the same manner as the sample, and a warm-up sample was evaluated prior to sample evaluation. The warm-up sample was the same each evaluation session and was used extensively during training. Panelists were also given water and napkins for mouth and hand cleansing and were instructed to expectorate all samples in order to measure residual mouthfeel. Testing occurred at the same time each day, and the samples were randomized so that each age of each cheese was evaluated three times over a two-day period.

### Statistical Analysis

Analysis of variance (PROC MIXED) was done on the sensory terms using the SAS statistical software package (Version 8.2, SAS Institute, Inc., Cary, NC) and least squares means were calculated; pair-wise comparison of significant differences between means of cheeses was done and significance was established at  $P \leq 0.05$  (age effects within cheese variety were compared for the sensory data). A repeated measures model was utilized and each sensory term (see Table 1) was determined and analyzed in a  $2 \times 4 + 1 \times 1$  (variety  $\times$  age + variety  $\times$  age) incomplete cross factorial design:

$$Y_{ijklm} = \mu + \alpha_i + \beta_j + (\alpha\beta)_{ij} + S_k + B_l + E_{klm}$$

$$\text{Sensory term} = \text{Overall mean} + (\text{variety})_i + (\text{age})_j + (\text{variety} \times \text{age})_{ij} + (\text{judge})_k + (\text{batch})_l + (\text{error})_{klm}$$

where

i= 1, 2, 3, 4 (age)

j= 1, 2, 3 (variety)

k=1, 2, 3, 4, 5, 6, 7, 8, 9, 10, 11, 12, 13, 14, 15 (judge)

l= 1, 2 (batch)

m= 1, 2, 3 (replicate)

Correlation analysis (PROC CORR) was executed to determine individual relationships among sensory data and among sensory and instrumental data. The experimental unit used for analysis of the sensory terms was the least squares means of each variety x age x batch treatment (n=18); the experimental unit used for analysis of the instrumental terms was the means of each variety x age x batch treatment (n=18). Principal component analysis (PROC PRINCOMP) was used to make visual comparisons of how the instrumental and sensory variables differentiated the cheeses. The experimental unit reported for the correlation analysis was used for principal component analysis.

## **RESULTS AND DISCUSSION**

### **Rheological Characterization**

A thorough discussion of the results of the rheological characterization is given in an accompanying manuscript. In summary, Mozzarella, Pizza, and Process cheese all had greater elastic components ( $G'$ ) than viscous components ( $G''$ ) and were highly frequency dependent, indicating the cheeses were viscoelastic, weak gels. Trends in the elastic behavior of these cheeses as they aged were able to differentiate these varieties. The changes in the relative elastic and viscous components of these materials ( $\delta$ , phase angle) as frequency changed created a unique fingerprint of cheese maturation behavior. As the cheeses aged,  $\delta$  decreased, showing that the elastic component of the cheeses was becoming less dominant. Creep recovery analysis showed an age dependent trend; as the cheeses aged, the maximum creep compliance ( $J_{mx}$ ) increased. Fracture characterization differentiated these cheeses based upon variety and age. Overall, as the natural cheeses aged, the rheological measurements showed that the cheeses became less firm and more elastic. It is

hypothesized that proteolysis due to residual enzyme and brine migration would explain such changes.

### **Differentiation by Sensory Means**

Five sensory terms were able to differentiate the ages of the cheeses within varieties as shown in Table 2. Mozzarella and Pizza cheese both became significantly less firm over time (as measured by the mouth). These cheeses appeared to break down more in the mouth after being chewed as the cheese aged. The degree to which Pizza cheese broke down over time was higher than the Mozzarella. Both Mozzarella and Pizza cheese became more cohesive after chewdown over time. Mozzarella did not change in mouth adhesiveness over time whereas Pizza cheese did become significantly more adhesive. Mozzarella and Pizza cheese also became significantly smoother after chewdown over time.

### **Correlation Analysis**

*Relationships among sensory terms.* Pearson's correlation analysis was used to determine relationships among sensory terms as shown in Table 3. Hand and first bite firmness were highly correlated. Both firmness measurements were correlated with fracturability showing that the firmer cheeses tended to fracture into more pieces when force was added. Springiness and rate of recovery were also highly correlated; cheeses that showed high amount of total recovery after depression recovered at a faster rate than cheeses showing a less total degree of recovery. Negative correlation was seen between fracturability and certain chewdown terms (breakdown, cohesiveness, and smoothness) implying that when cheeses fractured into many pieces upon biting, those pieces maintained their individuality as one chewed. All of the chewdown and residual terms were highly correlated with each other. Highly cohesive cheese were perceived as smooth and adhered to the mouth surfaces; upon

expectoration, the mouth coating was expected to be high due to the high adhesion of the chewed mass, and the smoothness of the coating would also be expected to be high since the original mass was perceived as smooth. Similar relationships have been reported. Drake et al. (1999a) found that hand and mouth evaluated firmness were highly correlated; mouth cohesiveness, smoothness, and stickiness to the teeth were also correlated. Like the results reported in this paper, they also found that crumbly cheeses (i.e. high fracturability) were low in mouth smoothness, cohesiveness and adhesiveness.

***Relationships among instrumental and sensory terms.*** The correlations observed between the instrumental and sensory data are shown in Table 4. Many instrumental terms correlated with perceived firmness. Positive correlations were observed between perceived firmness and  $G^*$ ,  $G'$ , and  $G_f$ . These measurements are ratios of force to deformation. Firm cheeses would require more force than soft cheese to result in the same amount of deformation. Likewise,  $G'$  is a measurement of the elastic component in a viscoelastic material and is an indication of the rigidity of the network. Cheeses having a higher  $G'$  were perceived as firmer.

Perceived firmness was highly negatively correlated with  $\delta$  and  $J_{mx}$ . Phase angle is a measurement of the difference between the input strain/stress and the response of the material. Sensorily firmer cheeses had lower  $\delta$ , showing that the input and response sinusoidal curves were highly in-phase, an indication of the dominance of the elastic component in this material. Additionally, firm cheeses would respond less to an applied force, and therefore would comply less. Drake et al. (1999b) showed that cheeses perceived to be less firm, showed higher compliance. Sensorily firm cheeses also showed a positive correlation with crp. Percent creep (crp) is a measurement of how much a sample returns to

its original shape after reaching full strain in a given time period. Very firm cheeses have a small full deformation, therefore the amount of strain change needed for total recovery would be less. In the given time period, firmer cheeses would appear to recover more since the amount of strain change it would have to make for full recovery would be relatively less than the amount of strain change a less firm cheese would have to make in the same time period. Drake et al. (1999b) made similar observations.

In addition to sensory firmness, correlations among sensory terms and  $G_f$  were observed; specifically, springiness and rate of recovery correlated negatively with  $G_f$ . Additionally, two chewdown terms (degree of breakdown and adhesiveness) showed slight correlations. This suggests that  $G_f$ , being a large strain measurement, might detect other elements in the materials.

Very few correlations were seen among instrumental and chewdown parameters, with two terms (cohesiveness and smoothness) showing no correlations with any instrumental parameters.

### **Principal Component Analysis**

Principal component analysis was used to examine how the instrumental and sensory methods were able to differentiate the cheeses.

***Sensory results.*** The sensory results showed that 96.1% of the total variation in samples could be explained by three principal components. Eigenvectors are nonzero vectors which are obtained by linearly transforming the original data using some scalar (the eigenvalue); they can be used to determine the relative influence of the parameter loadings on the specific principal component. The eigenvector loadings for this analysis are given in Table 5. Figure 2 shows principal component one (PC1) and two (PC2). Principal



component one explained 55.8% of the variance seen in the samples and was able to chronologically differentiate the natural cheeses (Mozzarella and Pizza cheese) according to age; as the cheeses aged, they showed higher PC1 values. The analysis showed that all of the chewdown and residual terms loaded highly on PC1 indicating that as the cheese aged, its chewed bolus became smoother, more cohesive, and broke down to a higher degree, as well as adhered to mouth surfaces more. It also left more of a smooth residual mouth coating.

Principal component two accounted for 26.1% of the total sample variation and also established the age-dependent nature of the sensory perception of the texture of these same cheeses. Hand and mouth firmness and fracturability loaded positively on PC2, whereas hand springiness and rate of recovery loaded negatively. As the cheese aged, they became less firm and fractured less while, simultaneously, they became springier and recovered more quickly when depressed.

Process cheese showed the highest values of PC1 and PC2 of any of the cheeses. It was very firm, not springy, and had a very cohesive, smooth bolus that highly adhered to mouth surfaces. These characteristics designated it from the natural cheeses.

The effects of principal component three (PC3; 14.2% of the total variance) are shown in Figure 3. The natural cheese varieties were categorically differentiated by PC3; Mozzarella had lower PC3 values than the Pizza cheese. The parameters of PC3 that were positively related were springiness, rate of recovery, and firmness. Relatively speaking, Pizza cheese was slightly springier, recovered faster, and was firmer than the Mozzarella, though these distinctions were not apparent in mean analysis procedures.

***Differentiation by both instrumental and sensory parameters.*** Principal component analysis was also done on the instrumental and sensory variables together in order to explore

characterizing capabilities of the combination of both methods. Three principal components were able to define 83.6% of the variation in these cheeses; eigenvector loadings are given in Table 6. Figure 4 shows principal component one (PC1) and two (PC2) from this analysis. When looking at just the loadings of the dependent variables on the biplot of PC1 versus PC2, three groupings of terms are observed. The first grouping is seen in the upper left quadrant and includes  $G^*$ ,  $G'$ ,  $G_f$ , and sensory firmness. All of these terms relate to the rigidity of the material. The second grouping of terms is seen in the center of the lower two quadrants and includes  $J_{mx}$ ,  $\lambda_{ret}$ ,  $\delta$ , sensory springiness, and sensory rate of recovery. All of these terms relate to the resiliency of the samples. Finally, the third grouping is in the upper right quadrant and consists of only the sensory chewdown and residual terms. It was noted that no instrumental terms were included in this grouping.

Principal component one (PC1) accounted for 41.9% of the total variation in the samples and was able to differentiate the cheeses by variety. It was positively driven by the torsional parameters ( $G_f$ ), the small strain parameters ( $G^*$  and  $G'$ ), and sensory firmness. Process cheese fractured ( $G_f$ ) at a much higher value than the other cheeses, indicating that it took more force (or less deformation) to cause the cheese to fracture. This was expected, as this Process cheese was a very dense, hard cheese when compared to the other cheeses. Likewise, Pizza cheese was slightly firmer and more isotropic than the Mozzarella cheese, characteristics that could cause differentiation by the PC1 parameters. Instrumental terms ( $J_{mx}$  and  $\lambda_{ret}$ ) and sensory terms (hrc and hsp) loaded negatively on PC1. The Mozzarella was the most pliant of the cheeses. Furthermore, PC1 slightly distinguished the cheeses by age; as the cheeses matured, their loadings on PC1 slightly decreased showing that they were becoming less rigid and more resilient.

It has been shown by instrumental means that aging in Cheddar cheese results in a decrease in firmness, fracture stress and fracture strain (Creamer and Olson, 1982). Amounts of  $\alpha_{s1}$  casein have been shown to decrease over larger intervals of aging due to proteolysis by residual coagulant in Cheddar (Fenelon and Guinee, 2000) and in Mozzarella (Tunick et al., 1993); these same cheeses showed a decrease in instrumental firmness/hardness. This degradation of the casein in the cheeses would cause a weakening of the protein matrix that makes up the basic structure of the cheeses, resulting in less firm, more elastic cheeses. Likewise, Subramanian and Gunasekaran (1997a) showed that  $G'$  decreased in Mozzarella cheese as they matured.

Principal component two (PC2), accounting for 29.2% of the total sample variation, ordered the cheeses chronologically. It represented the chewdown and residual sensory characterization as well as the perceived fracture properties of the cheese (negative relationship). As the cheeses aged, they became more cohesive, smooth, and sticky when chewed, and they fractured less.

The natural cheeses were categorically separated by principal component three (PC3; 12.4% of the total variation) as is seen in Figure 5. Pizza cheese loaded higher on PC3 than the Mozzarella; sensory springiness and rate of recovery was highly positively related to PC3. Additionally,  $J_0$  and  $G''$  loaded positively on PC3. Instantaneous compliance ( $J_0$ ) is the compliance at time zero; it is a measurement of the initial elastic response of the protein matrix when a force is applied. A high  $J_0$  would indicate that the sample initially deforms to a greater extent when a constant force is applied. The viscous component of the material is represented by  $G''$ ; Pizza cheese was higher in  $G''$  than the Mozzarella. This could be due to the structural differences in these cheeses. Due to the stretching of the plasticized curds that

occurs during manufacture, the protein matrix of the Mozzarella becomes elongated resulting in the characteristic fibrous texture of the cheese (Taneya et al., 1992). Perhaps because of the types of interactions of this system, the proteins are more available to interact with the serum phase. Sodium chloride in the cheese promotes the solubilization of intact caseins from the para-casein matrix; it is hypothesized that these proteins are able to freely migrate between the matrix and the serum phase (Guo and Kindstedt, 1995; Guo et al., 1997). An increase in soluble protein content in the serum phase could cause an increase in the viscosity of the filler, causing decrease in  $G''$ .

## CONCLUSIONS

Physical and perceptual characteristics combined were able to differentiate the cheese by variety and by age. Three distinct grouping of terms were observed relating to the rigidity, resiliency, and chewdown perception of the cheeses. As the cheeses aged, they became less rigid and more resilient. They also increased in all chewdown characteristics. These groupings also showed the relationships between small strain rheological properties and certain sensory perceptions. For example, within the rigidity grouping,  $G'$ ,  $G_f$ , and sensory firmness were correlated. This study suggests moving from empirical, imitative-type measurements, to more fundamental measurements to understand textural differences. Furthermore, the transitions in such fundamental and perceptual properties during the very early stages of ripening could aid in determining final cheese texture and effectiveness in certain functional properties such as machinability, melt, stretch, etc. This work has laid the foundation for future studies exploring the impact of such transitions on the functional properties of cheese.

## **ACKNOWLEDGMENTS**

We are grateful for the support from the Southeast Dairy Foods Research Center, Dairy Management, Inc., and the University of Wisconsin researchers. We would like to thank Paige Luck and Dr. Den Truong for their technical support as well as those individuals whom dedicated their time to participate in sensory panels.

## REFERENCES

- Adda, J., J. C. Gripon, and L. Vassal. 1982. The chemistry of flavour and texture generation in cheese. *Food Chem.* 9:115-129.
- Ak, M. M., and S. Gunasekaran. 1997. Anisotropy in tensile properties of Mozzarella cheese. *J. Food Sci.* 62:1031-1033.
- Bogue, J. C., C. M. Delahunty, M. K. Henry, and J. M. Murray. 1999. Market-oriented methodologies to optimize consumer acceptability of Cheddar-type cheeses. *Brit. Food J.* 101:301-316.
- Bourne, M. C. 1975. Is rheology enough for food texture measurement? *J. Texture Stud.* 6:259-262.
- Bowland, E. L., and E. A. Foegeding. 1995. Effects of anions on thermally induced whey protein isolate gels. *Food Hydrocoll.* 9:47-56.
- Bowland, E. L., and E. A. Foegeding. 1999. Factors determining large-strain (fracture) rheological properties of model processed cheese. *J. Dairy Sci.* 82:1851-1859.
- Brandt, M. A., E. Z. Skinner, and J. A. Coleman. 1963. Texture profile method. *J. Food Sci.* 28:404-409.
- Casiraghi, E., M. Lucisano, and C. Pompei. 1989. Correlation among instrumental texture, sensory texture and chemical composition of five Italian cheeses. *Ital. J. Food Sci.* 1:53-63.
- Chen, A. H., J. W. Larkin, C. J. Clark, and W. E. Irwin. 1979. Textural analysis of cheese. *J. Dairy Sci.* 62:901-907.
- Christensen, C. M. 1984. Food texture perception. *Adv. Food Research.* 29:159-199.
- Creamer, L. K., and N. F. Olson. 1982. Rheological evaluation of maturing Cheddar cheese.

- J. Food Sci. 47:631-636.
- Diehl, K. C. and D. D. Hamann. 1979. Structural failure in selected raw fruits and vegetables. J. Texture Stud. 10:371-400.
- Drake, M. A., P. D. Gerard, and G. V. Civille. 1999a. Ability of hand evaluation versus mouth evaluation to differentiate texture of cheese. J. Sens. Stud. 14:425-441.
- Drake, M. A., P. D. Gerard, V. D. Truong, and C. R. Daubert. 1999b. Relationship between instrumental and sensory measurements of cheese texture. J. Texture Stud. 30:451-476.
- Fenelon, M. A., and T. P. Guinee. 2000. Primary proteolysis and textural changes during ripening in Cheddar cheeses manufactured to different fat contents. Int. Dairy J. 10:151-158.
- Friedman, H. H., J. E. Whitney, and A. S. Szczesniak. 1963. The texturometer- a new instrument for objective texture measurement. J. Food Sci. 28:390-396.
- Guinard, J. X., and R. Mazzucchelli. 1996. The sensory perception of texture and mouthfeel. Trends Food Sci. Technol. 7:213-219.
- Guinee, T. P., M. A. E. Auty, and M. A. Fenelon. 2000. The effect of fat content on the rheology, microstructure and heat-induced functional characteristics of Cheddar cheese. Int. Dairy J. 10:277-288.
- Guo, M. R., J. A. Gilmore, and P. S. Kindstedt. 1997. Effect of sodium chloride on the serum phase of Mozzarella cheese. J. Dairy Sci. 80:3092-3098.
- Guo, M. R., and P. S. Kindstedt. 1995. Age-related changes in the water phase of Mozzarella cheese. J. Dairy Sci. 78:2099-2107.
- Gwartney, E. A., E. A. Foegeding, and D. K. Larick. 2002. The texture of commercial full-fat

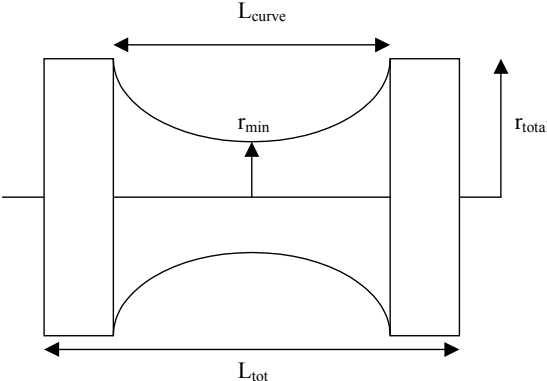
- and reduced-fat cheese. *J. Food Sci.* 67:812-816.
- Hamann, D. D. 1983. Structural failure in solid foods. Pages 351-383 *in* Physical Properties of Foods. M. Peleg and E. B. Bagley. ed. AVI Publishing Company, Inc., Westport, CT.
- Hsieh, Y. L., J. J. Yun, M. A. Rao. 1993. Rheological properties of Mozzarella cheese filled with dairy, egg, soy proteins, and gelatin. *J. Food Sci.* 58:1001-1004.
- Jack, F. R., J. R. Piggott, and A. Paterson. 1993. Relationships between rheology and composition of Cheddar cheeses and texture as perceived by consumers. *Int. J. Food Sci. Technol.* 28:293-302.
- Lee, C. H., E. M. Imoto, and C. Rha. 1978. Evaluation of cheese texture. *J. Food Sci.* 43:1600-1605.
- Ma, L., M. A. Drake, G. V. Barbosa Canovas, and B. G. Swanson. 1996. Viscoelastic properties of reduced-fat and full-fat cheddar cheeses. *J. Food Sci.* 61:821-823.
- McEwan, J. A., J. D. Moore, and J. S. Colwill. 1989. The sensory characteristics of Cheddar cheese and their relationship with acceptability. *J. Soc. Dairy Technol.* 42:112-117.
- Munoz, A. M., and G. V. Civille. 1998. Universal, product and attribute specific scaling and the development of common lexicons in descriptive analysis. *J. Sens. Stud.* 13:57-75.
- Murray, J. M., and C. M. Delahunty. 2000. Mapping consumer preference for the sensory and packaging attributes of Cheddar cheese. *Food Qual. Prefer.* 11:419-435.
- Nadai, A. 1937. Plastic behavior of metals in the strain-hardening range. Part I. *J. Appl. Physics.* 8:205-213.
- Nolan, E. J., V. H. Holsinger, and J. J. Shieh. 1989. Dynamic rheological properties of natural and imitation Mozzarella cheese. *J. Texture Stud.* 20:179-189.



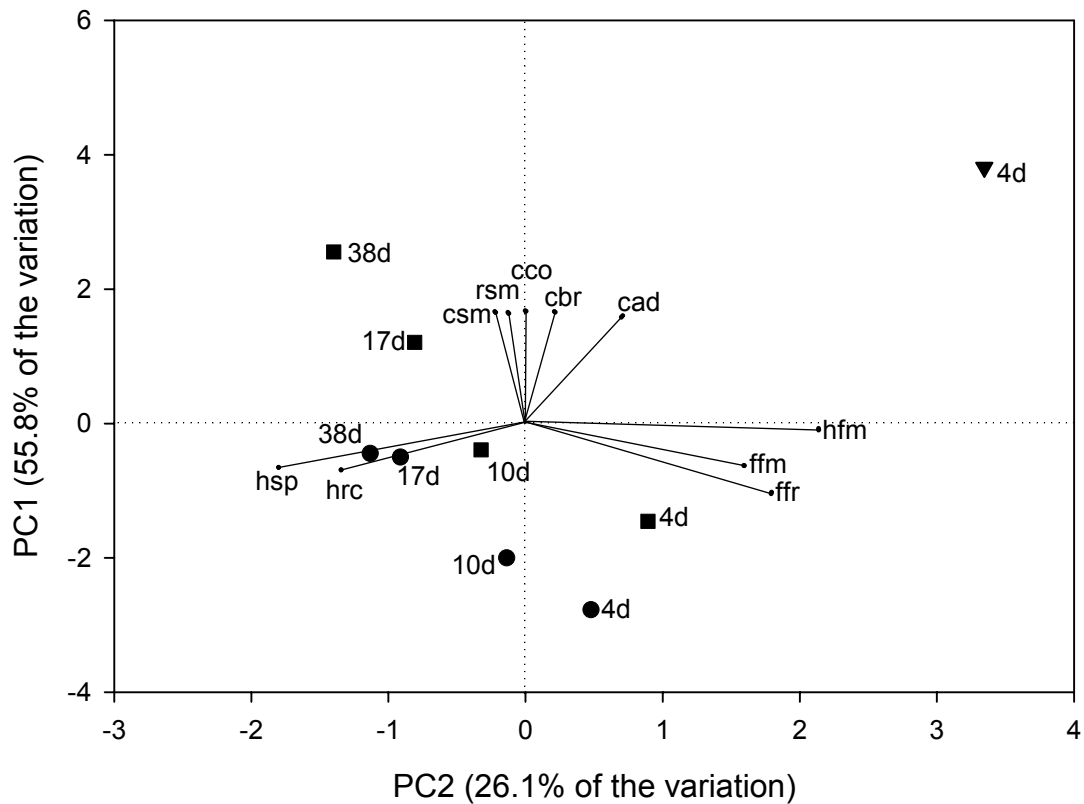
- Prentice, J. H. 1972. Rheology and texture of dairy products. *J. Texture Stud.* 3:415-458.
- Prentice, J. H. 1987. Cheese rheology. Pages 299-344 *in* Cheese: Chemistry, Physics, and Microbiology. Vol. 1. P. F. Fox, ed. Elsevier Science Publishing Company, Inc., New York, NY.
- Rosenberg, M., Z. Wang, S. L. Chuang, and C. F. Shoemaker. 1995. Viscoelastic property changes in Cheddar cheese during ripening. *J. Food Sci.* 60:640-644.
- Sharma, F., and P. Sherman. 1973. Evaluation of some textural properties of foods with the Instron Universal Testing Machine. *J. Texture Stud.* 4:344-353.
- Steffe, J. F. 1996. *Rheological Methods in Food Process Engineering*. Freeman Press, East Lansing, MI.
- Subramanian, R., and S. Gunasekaran. 1997a. Small amplitude oscillatory shear studies on Mozzarella cheese: Part I. Region of linear viscoelasticity. *J. Texture Stud.* 28:633-642.
- Subramanian, R., and S. Gunasekaran. 1997b. Small amplitude oscillatory shear studies on Mozzarella cheese: Part II. Relaxation spectrum. *J. Texture Stud.* 28:643-656.
- Szczesniak, A. S. 1963. Classification of textural characteristics. *J. Food Sci.* 28:385-389.
- Szczesniak, A. S., M. A. Brandt, and H. H. Friedman. 1963. Development of standard rating scales for mechanical parameters of texture and correlation between the objective and the sensory methods of texture evaluation. *J. Food Sci.* 28:397-403.
- Taneya, S., T. Izutsu, T. Kimura, T. Shioya, W. Buchheim, P. S. Kindstedt, and D. G. Pechak. 1992. Structure and rheology of string cheese. *Food Struct.* 11:61-71.
- Tolstoguzov, V. B., and E. E. Braudo. 1983. Fabricated foodstuffs as multicomponent gels. *J. Texture Stud.* 14:183-212.

- Truong, V. D., and C. R. Daubert. 2000. Comparative study on large strain methods in assessing failure characterization of selected food gels. *J. Texture Stud.* 31:335-353.
- Tunick, M. H. 2000. Rheology of dairy foods that gel, stretch, and fracture. *J. Dairy Sci.* 83:1892-1898.
- Tunick, M. H., K. L. Mackey, P. W. Smith, and V. H. Holsinger. 1991. Effects of composition and storage on the texture of Mozzarella cheese. *Neth. Milk Dairy J.* 45:117-125.
- Tunick, M. H., E. L. Malin, P. W. Smith, J. J. Shieh, B. C. Sullivan, K. L. Mackey, and V. H. Holsinger. 1993. Proteolysis and rheology of low-fat and full-fat Mozzarella cheeses prepared from homogenized milk. *J. Dairy Sci.* 76:3621-3628.
- Tunick, M. H., E. J. Nolan, J. J. Shieh, J. J. Basch, M. P. Thompson, B. E. Maleeff, and V. H. Holsinger. 1990. Cheddar and Cheshire cheese rheology. *J. Dairy Sci.* 73:1671-1675.
- van Vliet, T., and P. Walstra. 1983. Rheology of curd and cheese. *Neth. Milk Dairy J.* 37:93-94.
- Wendin, K., M. Langton, L. Caous, and C. Hall. 2000. Dynamic analyses of sensory and microstructural properties of cream cheese. *Food Chem.* 71:363-378.
- Wilkinson, C., G. B. Dijksterhuis, and M. Minekus. 2000. From food structure to texture. *Trends Food Sci. Technol.* 11:442-450.

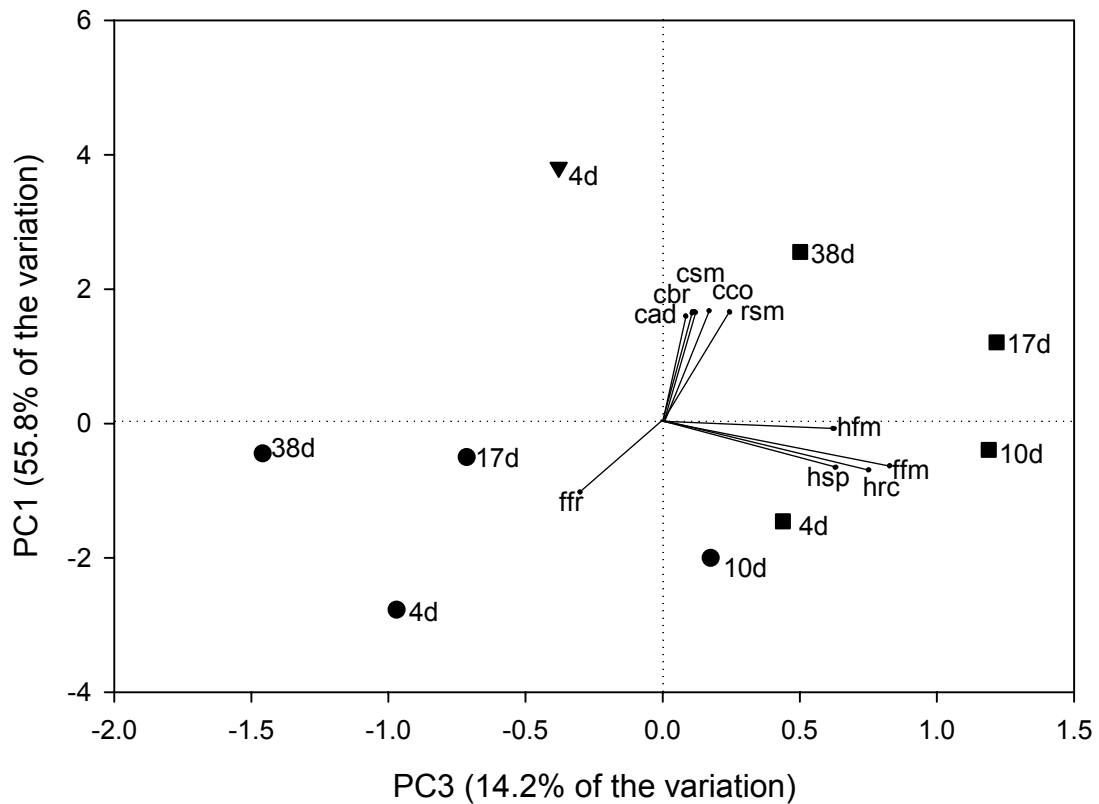
**FIGURES AND TABLES**



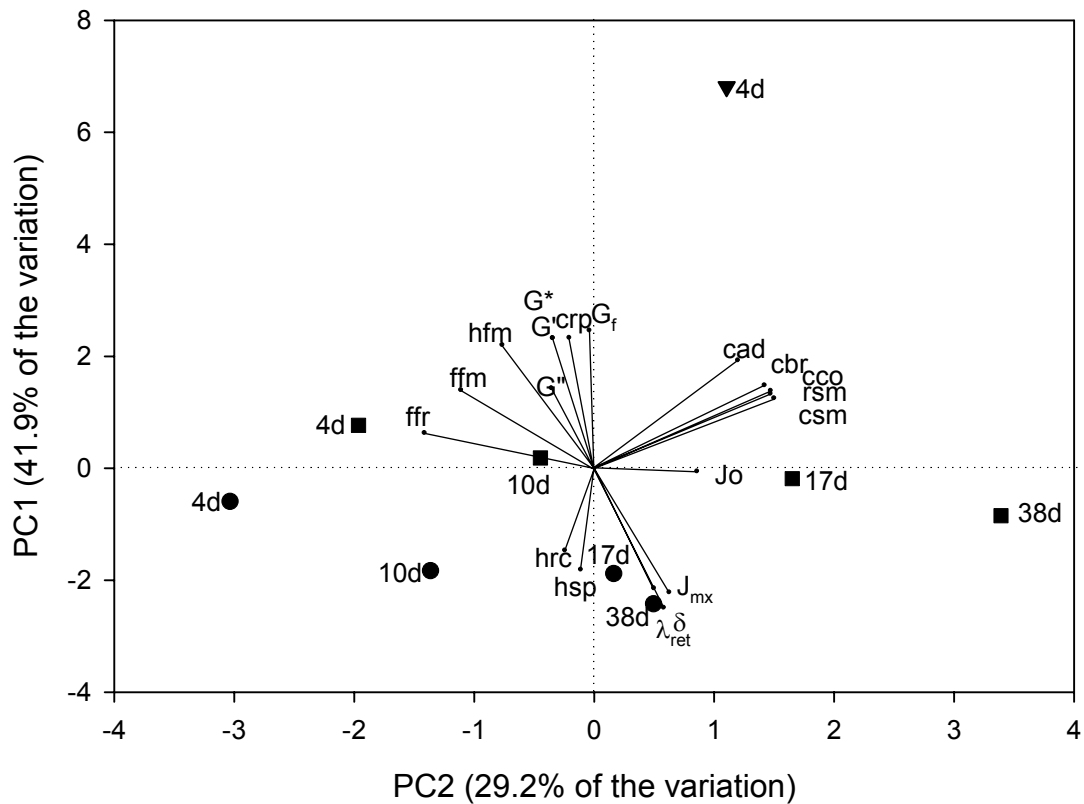
**Figure 1.** Capstan geometry used for torsional testing; Key for measurements: Total cylinder length ( $L_{tot}$ ), Length of capstan curved section ( $L_{curve}$ ), Radius of upper edge of capstan ( $r_{total}$ ), Minimum radius of capstan curved section ( $r_{min}$ ).



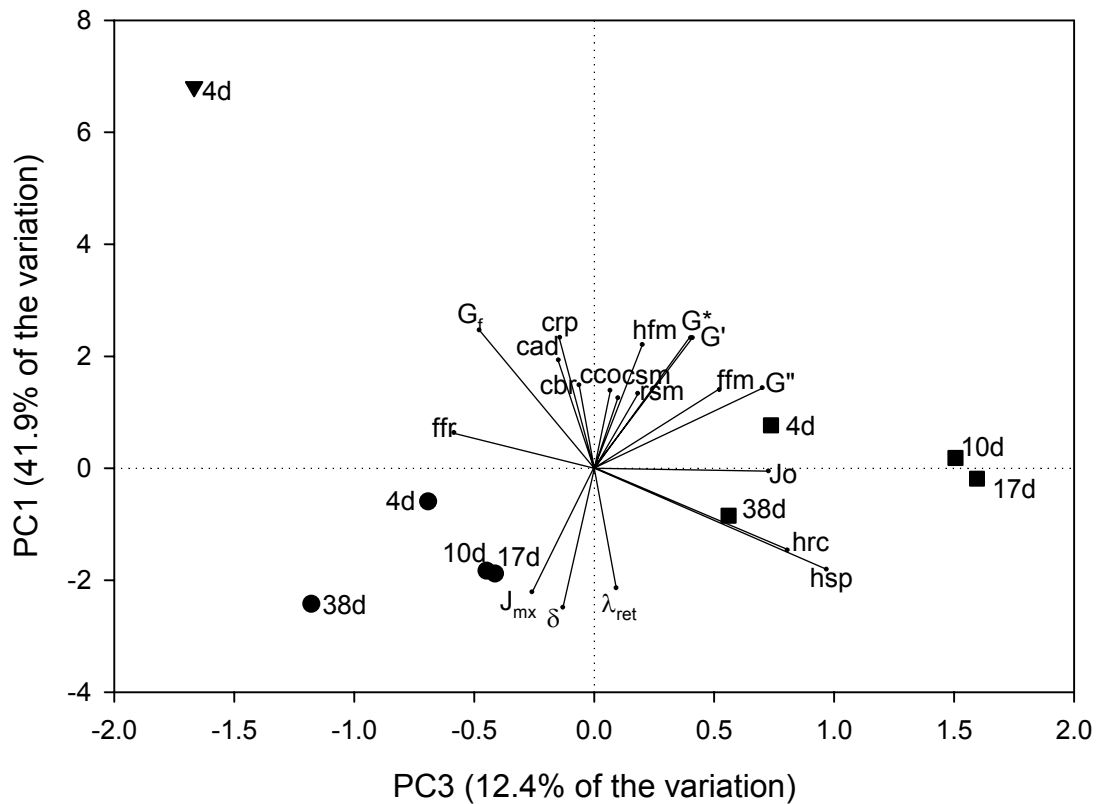
**Figure 2.** Principal component analysis biplot of sensory parameters used to differentiate Mozzarella (●), Pizza (■), and Process (▼) cheeses by age (indicated by numbers beside symbol). Key for sensory parameters: Hand firmness (hfm), Hand springiness (hsp), Hand rate of recovery (hrc), First bite firmness (ffm), First bite fracturability (ffr), Chewdown degree of breakdown (cbr), Chewdown cohesiveness (cco), Chewdown adhesiveness (cad), Chewdown smoothness (csm), Residual smoothness (rsm).



**Figure 3.** Principal component analysis biplot of sensory parameters used to differentiate Mozzarella (●), Pizza (■), and Process (▼) cheeses by age (indicated by numbers beside symbol). Key for sensory parameters: Hand firmness (hfm), Hand springiness (hsp), Hand rate of recovery (hrc), First bite firmness (ffm), First bite fracturability (ffr), Chewdown degree of breakdown (cbr), Chewdown cohesiveness (cco), Chewdown adhesiveness (cad), Chewdown smoothness (csm), Residual smoothness (rsm).



**Figure 4.** Principal component analysis biplot of sensory and instrumental parameters used to differentiate Mozzarella (●), Pizza (■), and Process (▼) cheeses by age (indicated by numbers beside symbol). Key for sensory parameters: Hand firmness (hfm), Hand springiness (hsp), Hand rate of recovery (hrc), First bite firmness (ffm), First bite fracturability (ffr), Chewdown degree of breakdown (cbr), Chewdown cohesiveness (cco), Chewdown adhesiveness (cad), Chewdown smoothness (csm), Residual smoothness (rsm). Key for instrumental parameters: Complex modulus ( $G^*$ ), Storage modulus ( $G'$ ), Loss modulus ( $G''$ ), Phase angle ( $\delta$ ), Fracture modulus ( $G_f$ ), Initial compliance ( $J_0$ ), Maximum compliance ( $J_{mx}$ ), Percent creep recovery (crp), Retardation time ( $\lambda_{ret}$ ).



**Figure 5.** Principal component analysis biplot of sensory and instrumental parameters used to differentiate Mozzarella (●), Pizza (■), and Process (▼) cheeses by age (indicated by numbers beside symbol). Key for sensory parameters: Hand firmness (hfm), Hand springiness (hsp), Hand rate of recovery (hrc), First bite firmness (ffm), First bite fracturability (ffr), Chewdown degree of breakdown (cbr), Chewdown cohesiveness (cco), Chewdown adhesiveness (cad), Chewdown smoothness (csm), Residual smoothness (rsm). Key for instrumental parameters: Complex modulus ( $G^*$ ), Storage modulus ( $G'$ ), Loss modulus ( $G''$ ), Phase angle ( $\delta$ ), Fracture modulus ( $G_f$ ), Initial compliance ( $J_0$ ), Maximum compliance ( $J_{mx}$ ), Percent creep recovery (crp), Retardation time ( $\lambda_{ret}$ ).

**Table 1.** Language used to evaluate cheese texture perception; evaluation techniques, term definitions, and references are given.

<b>Term (Abbreviation)</b>	<b>Definition</b>	<b>Technique</b>	<b>Reference</b>
Hand Firmness (hfm)	The amount of force required to completely compress the sample.	Press completely through the sample using the thumb and first two fingers.	3= Process cheese <sup>1</sup> 7= Muenster <sup>2</sup> 10= Sharp Cheddar <sup>3</sup> 14= Parmesan <sup>4</sup>
Hand Springiness (hsp)	The total amount of recovery of the sample.	Press the sample between the thumb and first two fingers until it is depressed 30%.	1= Parmesan 4= Process cheese 7= Sharp Cheddar 13= Muenster
Hand Rate of Recovery (hrc)	The rate at which the sample recovers (i.e. the speed at which the sample returns to its original shape).	Press the sample between the thumb and first two fingers until it is depressed 30%.	1= Feta <sup>5</sup> 4= Process cheese 7= Muenster
First Bite Firmness (ffm)	The amount of force required to completely bite through the sample.	Completely bite through the sample using the molars.	3= Process cheese 7= Muenster 10= Sharp Cheddar 14= Parmesan
First Bite Fracturability (ffr)	The amount of fracturability in the sample after biting.	Completely bite through the sample using the molars.	1= Process cheese 5= Sharp Cheddar 14= Feta
Chewdown Degree of Breakdown (cbr)	The amount of breakdown that occurs in the sample as a result of mastication (i.e. the amount of meltability or dissolvability).	Chew the sample 5 times and evaluate the chewed mass.	1= Parmesan 10= Sharp Cheddar 14= Process cheese
Chewdown Cohesiveness (cco)	The degree to which the chewed mass holds together.	Chew the sample 5 times and evaluate the chewed mass.	1= Parmesan 3= Feta 9= Muenster 14= Process cheese
Chewdown Adhesiveness (cad)	The degree to which the chewed mass sticks to mouth surfaces.	Chew the sample 5 times and evaluate the chewed mass.	1= Parmesan 7= Muenster 12= Feta 14= Process cheese
Chewdown Smoothness of Mass (csm)	The degree to which the chewed mass surface is smooth (i.e. evaluation for gritty or grainy particles).	Chew the sample 5 times and evaluate the chewed mass.	1= Parmesan 3= Feta 8= Muenster 14= Process cheese
Residual Smoothness of Mouth Coating (rsm)	The degree of smoothness felt in the mouth after expectorating the sample.	Chew the sample 5 times, expectorate, and evaluate the residual in the mouth.	1= Parmesan 5= Feta 10= Muenster 14= Process cheese

<sup>1</sup>Process cheese: Velveeta brand 907-g loaf (Kraft Foods North America; Glenview, IL)

<sup>2</sup>Muenster: Harris Teeter brand (Harris Teeter; Matthews, NC)

<sup>3</sup>Sharp Cheddar: Kraft brand 227-g block (Kraft Foods; Glenview, IL)

<sup>4</sup>Parmesan: Kraft brand 113-g triangle (Kraft Foods; Glenview, IL)

<sup>5</sup>Feta: Athenos brand 227-g block (Churny Company, Inc.; Weyauwega, WI)



**Table 2.** Differences in least squares means of ages within cheese varieties (standard errors are given in parentheses). Key for acronyms: First bite firmness (ffm), Chewdown degree of breakdown (cbr), Chewdown cohesiveness (cco), Chewdown adhesiveness (cad), Chewdown smoothness (csm).

Cheese	Age	ffm	cbr	cco	cad	csm
Mozzarella	4 d	8.99 <sup>a</sup> (0.81)	3.68 <sup>a</sup> (0.86)	3.34 <sup>a</sup> (1.06)	3.67 <sup>a</sup> (0.65)	3.36 <sup>a</sup> (1.27)
	10 d	9.32 <sup>a</sup> (0.81)	4.61 <sup>ab</sup> (0.86)	4.07 <sup>ab</sup> (1.06)	3.95 <sup>a</sup> (0.65)	4.03 <sup>ab</sup> (1.27)
	17 d	8.33 <sup>ab</sup> (0.81)	5.47 <sup>b</sup> (0.86)	5.27 <sup>b</sup> (1.06)	4.48 <sup>a</sup> (0.65)	5.05 <sup>b</sup> (1.27)
	38 d	7.74 <sup>b</sup> (0.81)	5.41 <sup>b</sup> (0.86)	5.17 <sup>b</sup> (1.06)	4.66 <sup>a</sup> (0.65)	4.91 <sup>b</sup> (1.27)
Pizza cheese	4 d	10.03 <sup>a</sup> (0.81)	4.61 <sup>a</sup> (0.86)	4.57 <sup>a</sup> (1.06)	4.16 <sup>a</sup> (0.65)	4.51 <sup>a</sup> (1.27)
	10 d	9.55 <sup>a</sup> (0.81)	5.94 <sup>ab</sup> (0.86)	5.75 <sup>ab</sup> (1.06)	5.05 <sup>a</sup> (0.66)	5.43 <sup>ab</sup> (1.28)
	17 d	9.11 <sup>ab</sup> (0.81)	7.19 <sup>bc</sup> (0.86)	7.29 <sup>bc</sup> (1.06)	6.28 <sup>b</sup> (0.65)	6.47 <sup>bc</sup> (1.27)
	38 d	8.27 <sup>b</sup> (0.81)	8.47 <sup>c</sup> (0.86)	8.46 <sup>c</sup> (1.06)	6.86 <sup>b</sup> (0.65)	7.52 <sup>c</sup> (1.27)
Process cheese	4 d	9.47 (0.81)	9.59 (0.86)	9.11 (1.06)	9.18 (0.65)	8.05 (1.27)

<sup>abc</sup> Means with same superscript are not significantly different at P>0.05.

**Table 3.** Correlation analysis of sensory terms used to describe cheese texture. Key for acronyms: Hand firmness (hfm), Hand springiness (hsp), Hand rate of recovery (hrc), First bite firmness (ffm), First bite fracturability (ffr), Chewdown degree of breakdown (cbr), Chewdown cohesiveness (cco), Chewdown adhesiveness (cad), Chewdown smoothness (csm), Residual smoothness (rsm).

	hfm	hsp	hrc	ffm	ffr	cbr	cco	cad	csm	rsm
hfm	1.000	-0.354	-0.178	<b>0.907<sup>***</sup></b>	<b>0.520<sup>*</sup></b>	0.065	0.018	0.230	-0.073	0.011
hsp		1.000	<b>0.748<sup>**</sup></b>	0.026	-0.440	-0.414	-0.321	<b>-0.564<sup>*</sup></b>	-0.264	-0.229
hrc			1.000	0.149	-0.216	-0.361	-0.310	-0.454	-0.310	-0.274
ffm				1.000	<b>0.514<sup>*</sup></b>	-0.265	-0.285	-0.137	-0.360	-0.266
ffr					1.000	<b>-0.533<sup>*</sup></b>	<b>-0.623<sup>*</sup></b>	-0.354	<b>-0.687<sup>**</sup></b>	<b>-0.678<sup>**</sup></b>
cbr						1.000	<b>0.990<sup>***</sup></b>	<b>0.973<sup>***</sup></b>	<b>0.954<sup>***</sup></b>	<b>0.966<sup>***</sup></b>
cco							1.000	<b>0.950<sup>***</sup></b>	<b>0.980<sup>***</sup></b>	<b>0.987<sup>***</sup></b>
cad								1.000	<b>0.903<sup>***</sup></b>	<b>0.915<sup>***</sup></b>
csm									1.000	<b>0.985<sup>***</sup></b>
rsm										1.000

\* Significant correlation at  $P \leq 0.05$ .

\*\* Significant correlation at  $P \leq 0.005$ .

\*\*\* Significant correlation at  $P \leq 0.0001$ .

**Table 4.** Correlation analysis of sensory and instrumental terms used to define cheese texture. Key for acronyms: Hand firmness (hfm), Hand springiness (hsp), Hand rate of recovery (hrc), First bite firmness (ffm), First bite fracturability (ffr), Chewdown degree of breakdown (cbr), Chewdown cohesiveness (cco), Chewdown adhesiveness (cad), Chewdown smoothness (csm), Residual smoothness (rsm), Complex modulus ( $G^*$ ), Storage modulus ( $G'$ ), Loss modulus ( $G''$ ), Phase angle ( $\delta$ ), Fracture modulus ( $G_f$ ), Instantaneous compliance ( $J_0$ ), Maximum compliance ( $J_{mx}$ ), Retardation time ( $\lambda_{ret}$ ), Percent creep recovery (crp).

	$G^*$	$G'$	$G''$	$\delta$	$G_f$	$J_0$	$J_{mx}$	$\lambda_{ret}$	crp
hfm	<b>0.619<sup>*</sup></b>	<b>0.623<sup>*</sup></b>	0.382	<b>-0.823<sup>***</sup></b>	<b>0.660<sup>**</sup></b>	0.005	<b>-0.921<sup>***</sup></b>	<b>-0.638<sup>**</sup></b>	<b>0.802<sup>***</sup></b>
hsp	-0.301	-0.296	0.072	0.465	<b>-0.832<sup>***</sup></b>	0.400	0.298	<b>0.534<sup>*</sup></b>	<b>-0.576<sup>*</sup></b>
hrc	-0.268	-0.270	0.051	0.435	<b>-0.575<sup>*</sup></b>	0.206	0.240	0.365	-0.381
ffm	<b>0.499<sup>*</sup></b>	<b>0.504<sup>*</sup></b>	0.403	<b>-0.671<sup>**</sup></b>	0.324	0.052	<b>-0.823<sup>***</sup></b>	-0.468	<b>0.581<sup>*</sup></b>
ffr	0.169	0.165	0.021	-0.402	0.417	<b>-0.609<sup>*</sup></b>	-0.418	-0.449	0.350
cbr	0.197	0.196	0.032	-0.137	<b>0.478<sup>*</sup></b>	0.405	-0.120	-0.153	0.364
cco	0.217	0.217	0.075	-0.123	0.391	0.459	0.000	-0.124	0.303
cad	0.341	0.340	0.112	-0.315	<b>0.646<sup>**</sup></b>	0.300	-0.268	-0.320	<b>0.503<sup>*</sup></b>
csm	0.237	0.239	0.099	-0.109	0.324	0.419	-0.024	-0.087	0.228
rsm	0.244	0.246	0.134	-0.119	0.345	<b>0.479<sup>*</sup></b>	-0.080	-0.090	0.269

\* Significant correlation at  $P \leq 0.05$ .

\*\* Significant correlation at  $P \leq 0.005$ .

\*\*\* Significant correlation at  $P \leq 0.0001$ .

**Table 5.** Eigenvector loadings for principal component analysis of sensory attributes describing perceived cheese texture. Key for acronyms: Hand firmness (hfm), Hand springiness (hsp), Hand rate of recovery (hrc), First bite firmness (ffm), First bite fracturability (ffr), Chewdown degree of breakdown (cbr), Chewdown cohesiveness (cco), Chewdown adhesiveness (cad), Chewdown smoothness (csm), Residual smoothness (rsm), Principal component one (PC1), Principal component two (PC2), Principal component three (PC3). Bolded numbers represent primary loadings.

Term	PC1	PC2	PC3
hfm	-0.019	<b>0.534</b>	0.417
hsp	-0.164	<b>-0.450</b>	0.419
hrc	-0.173	-0.336	<b>0.501</b>
ffm	-0.158	0.399	<b>0.552</b>
ffr	-0.256	<b>0.449</b>	-0.201
cbr	<b>0.416</b>	0.052	0.072
cco	<b>0.419</b>	-0.001	0.112
cad	<b>0.400</b>	0.177	0.056
csm	<b>0.416</b>	-0.056	0.078
rsm	<b>0.413</b>	-0.032	0.163

**Table 6.** Eigenvector loadings for principal component analysis of sensory and instrumental attributes describing cheese texture. Key for acronyms: Hand firmness (hfm), Hand springiness (hsp), Hand rate of recovery (hrc), First bite firmness (ffm), First bite fracturability (ffr), Chewdown degree of breakdown (cbr), Chewdown cohesiveness (cco), Chewdown adhesiveness (cad), Chewdown smoothness (csm), Residual smoothness (rsm), Complex modulus ( $G^*$ ), Storage modulus ( $G'$ ), Loss modulus ( $G''$ ), Phase angle ( $\delta$ ), Fracture modulus ( $G_f$ ), Instantaneous compliance ( $J_o$ ), Maximum compliance ( $J_{mx}$ ), Retardation time ( $\lambda_{ret}$ ), Percent creep recovery (crp), Principal component one (PC1), Principal component two (PC2), Principal component three (PC3). Bolded numbers represent primary loadings

Term	PC1	PC2	PC3
hfm	<b>0.276</b>	-0.192	0.100
hsp	-0.226	-0.029	<b>0.484</b>
hrc	-0.183	-0.062	<b>0.402</b>
ffm	0.175	<b>-0.278</b>	0.261
ffr	0.080	<b>-0.354</b>	-0.292
cbr	0.186	<b>0.354</b>	-0.032
cco	0.174	<b>0.367</b>	0.033
cad	0.242	<b>0.299</b>	-0.075
csm	0.157	<b>0.374</b>	0.049
rsm	0.167	<b>0.366</b>	0.091
$G^*$	<b>0.291</b>	-0.087	0.201
$G'$	<b>0.292</b>	-0.087	0.204
$G''$	0.180	-0.090	<b>0.350</b>
$\delta$	<b>-0.310</b>	0.144	-0.065
$G_f$	<b>0.309</b>	-0.011	-0.240
$J_o$	-0.006	0.214	<b>0.363</b>
$J_{mx}$	<b>-0.276</b>	0.156	-0.130
$\lambda_{ret}$	<b>-0.267</b>	0.124	0.046
crp	<b>0.292</b>	-0.053	-0.072

**COMPARISON OF TORSION AND VANE RHEOLOGICAL METHODS TO  
EVALUATE YOUNG CHEESE TEXTURE**

**J. A. Brown, E. A. Foegeding, and C. R. Daubert**

Department of Food Science  
North Carolina State University

## ABSTRACT

Food texture is an attribute used by consumers to determine acceptability and quality of cheeses. Large strain rheological properties have been shown to correlate well with certain sensory textural perceptions. In this research, the abilities of two large strain methods (torsion and vane rheometry) to measure certain fundamental rheological properties were compared. Cheeses (Mozzarella and Pizza) were tested over time (4, 10, 17, and 38 d); Process cheese was also tested (4 d). Fracture stresses and fracture strains (or apparent strain) at three different strain rates (0.0047, 0.047, and 0.47 s<sup>-1</sup>) were determined using both the torsion and vane methods to see how the large strain properties compared in different cheese types. Overall, vane fracture stresses were lower than torsion fracture stresses. As the strain rate increased, the fracture stresses increased. Simple linear regression of the torsion and vane fracture stresses revealed that the torsion fracture stresses were 1.997 times higher than the vane fracture stresses (R<sup>2</sup>=0.66). This information confirms previous unpublished findings by Truong and Daubert.

**(Key Words:** vane, torsion, texture, cheese)

**Abbreviation key:**  $L_{tot}$ = Total cylinder length,  $L_{curve}$ = Length of capstan curved section,  $r_{total}$ = Radius of upper edge of capstan,  $r_{min}$ = Minimum radius of capstan curved section,  $\sigma_t$ = True shear stress,  $\gamma_{t-true}$ = True shear strain,  $M$ = Torque,  $\phi_s$ = Angular deformation of capstan curved section,  $K$ = Shape factor constant,  $Q$ = Curvature section constant,  $G_f$ = Shear fracture modulus,  $\sigma_v$  = Vane shear stress,  $\gamma_v$  = Apparent strain,  $h$ = Vane height,  $d$ = Vane diameter,  $\Theta$ = Angular deformation at the vane edge,  $\Omega$ = Angular velocity,  $t$ = Time (s), and  $df/d$ =Ratio of the diameter of fractured area to the vane diameter

## INTRODUCTION

Texture in food is an important attribute that contributes to consumer acceptance and perception of quality. Sensory methods have been used to determine the perception of texture; such methods are able to qualify and quantify human perception over the range of actions occurring during consumption, from the visual and tactile elements assessed when first encountering the food through the perceptions encountered while chewing and swallowing. However, due to the extensive amount of resources that must be invested in generating and validating sensory data, attempts have been made to discover instrumental methods that would mimic human sensory perception.

Large strain rheological methods have been used to characterize cheese texture; such measurements occur outside of the linear viscoelastic region and characterize the fracture properties of the material. These types of methods relate well to sensory properties since mastication is a large strain action. Friedman et al. (1963) recognized that the action used to measure some sensory perceptions, in particular the mechanical properties of the mouth, could be mimicked using certain rheological instrumentation.

The mechanism by which materials fracture or yield was explained by van Vliet and Walstra (1995). When stresses are applied to a material, the bonds between the structural elements along a specific plane begin to rupture, resulting in failure of the material's structure at a much greater scale than the length of the actual structural elements. In fracturing a material, the material then falls apart due to the lack of structure. Conversely, when a material yields, the result is material flow.

Correlations between sensory and rheological data have been used to differentiate and define different cheese varieties. Many attempts have been made to discover instrumental



parameters that would predict sensory texture response in cheeses (Lee et al., 1978; Chen et al., 1979; Green et al., 1985; Casiraghi, 1989; Jack et al., 1993; Drake et al., 1999; Hort and Le Grys, 2000; Benedito et al. 2000).

Large strain rheological methods observe material in compression/tension or shear. Compression tests apply forces perpendicular to the material surface. Specifically, the popular instrumental Texture Profile Analysis (TPA) is a compressive test in which a sample is compressed one to two times to mimic biting in human mastication. Instrumental TPA has been used to observe the effects of fat content, moisture content, and storage conditions on the texture of Mozzarella in order to create low fat cheeses with textures similar to regular fat cheeses (Tunick et al., 1991). Similarly, Tunick et al. (1993) differentiated low-fat and full-fat Mozzarella cheeses made from homogenized milk at different cook temperatures; using instrumental TPA, they found that cheeses were harder at higher cooking temperatures.

Such tests have been criticized because friction between the surface of the sample and the compression plates contributes to the overall response of the material. For highly incompressible materials (Poisson's ratio is close to 0.5), the friction causes the sample to "barrel" or "bulge", rather than fracture (Kavanagh and Ross-Murphy, 1998). When a material behaves in this manner, the force being applied is no longer a true axial load. The use of lubrication can minimize the frictional effect.

In tensile tests, the samples are connected to an apparatus that pulls the sample apart until fracture occurs. Tensile tests have been used to characterize the anisotropic nature of Mozzarella cheese (Ak and Gunasekaran, 1997). These tests have also been criticized because of the difficulty in attaching weaker materials to the apparatus and the tendency for materials to fail at the point of attachment. To overcome this problem, notches can be cut

into the sample at a specific point to encourage failure at the notch rather than at the attachment site.

Torsion is another large strain method in which the sample is formed into a capstan shape of known dimensions (Figure 1). The capstan is then twisted at a chosen speed until it fractures. Due to the unique shape of the capstan, the point of fracture can be forced at the center of the capstan. Measurement of the capstan dimensions, the torque at fracture, and the time at fracture are used to calculate stress and strain at fracture (Nadai, 1937; Diehl et al., 1979; Hamann, 1983; Truong and Daubert, 2001). Torsional methods have been applied to identify textural changes in process cheese associated with changes in formulation and processing conditions (Bowland and Foegeding, 1999).

To compare compression-type tests with torsion, one must understand the differences in the types of stresses and strains obtained in each method. Stresses and strains are described as being dilatational or deviatoric. Dilatational stresses and strains cause changes in volume and shape; deviatoric parameters cause changes just in shape. When stresses and strains are dilatational, the resulting axial stress is twice the maximum shear stresses, and the resulting axial and shear strains are also skewed. However, in torsion tests, the stresses and strains are deviatoric; the method produces pure shear. The resulting normal and shear stresses are equal, and the resulting shear strains are twice the maximum normal strains (Hamann, 1983).

In cheese, torsional methods are more appropriate than compressive methods for studying fracture stresses and strains since cheese, being an incompressible material, may not be as sensitive to the shape changing stresses associated with compression tests. However, torsional methods have also been criticized due to the limitations of application (soft or

sticky foods cannot be shaped easily into the capstan shape) and due to the extensive nature of the sample preparation.

The vane method is another large strain test. In this method, a four to eight blade vane having a specified diameter and length is lowered into the sample and rotated at a specified speed (Figure 2). Yield stress and apparent yield strain were determined using the vane method to create texture maps to describe texture and spreadability of cream cheese (Breidinger and Steffe, 2001). The vane method is advantageous due to its simplicity in sample preparation, its applicability to a wide range of food consistencies, and its ability to minimize sample destruction. However, it is questionable whether such tests are purely fundamental for viscoelastic solids.

Large strain methods have been compared in order to develop methodology to describe fracture characteristics in cheeses. Breuil and Meullenet (2001) compared the ability of three large strain rheological methods (uniaxial compression, cone penetrometry, and puncture test) to predict cheese texture as observed by a trained panel. Though they were able to effectively predict six different textural characteristics using such methods to evaluate twenty-nine different cheese types, it was apparent that each of the instrumental techniques was best at determining different textural characteristics, implying that none of these methods are universally the best at defining the textural perception.

The ability of the vane and torsion methods to characterize cheeses has been compared (Truong and Daubert, 2001). Torsion shear stresses were higher than vane shear stresses, though comparing the placement of samples by the vane and torsion methods on texture maps showed that the relative placements of the samples were similar. This group concluded that the vane method would be appropriate to compare the textures of different

cheeses, given that the diameter of the vane fracture surface was approximately equal to the diameter of the vane.

The objective of this research was to compare the torsion and vane methods in their ability to characterize certain functional properties of cheeses, namely fracture stress and fracture strain. The effects of different strain rates were also observed.

## **MATERIALS AND METHODS**

### **Material Description**

Mozzarella, Pizza cheese, and High melt process cheese (referred to as Process cheese) were observed. Testing of the Mozzarella and Pizza cheeses occurred at 4, 10, 17, and 38 d of age; Process cheese was observed on 4 d of age. Mozzarella cheeses were manufactured by Alto Dairy Cooperative (Waupun, WI), the Pizza cheeses were crafted by Meister Cheese Company (Muscodia, WI), and Process cheese was made by Kraft (Glenview, IL). Cheeses were collected and shipped to North Carolina State University using temperature-controlled packaging material to ensure that the cheeses remained at appropriate temperatures during shipping. The cheese was shipped immediately following manufacture, and all aging occurred at North Carolina State University. The cheese was stored at 4° C in 4.5 kg blocks in Cryovac B series, vacuum-sealed bags. Approximately 3-cm of the outer edge of the cheese was removed prior to testing. The cheeses were allowed to come to room temperature before performing any of the tests.

### **Methods**

***Torsion analysis.*** Torsional methods were used to determine the fracture properties of the cheeses. Cylinders of cheese were formed using a 19-mm internal diameter cork

borer. The cylinders were cut to a length of 28.7-mm, and plastic disks (Gel Consultants, Raleigh, NC) were glued to the ends of the cylinder using cyanoacrylate glue (Loctite 100-Loctite Corporation, Rocky Hill, CT) to enable the samples to be mounted to the grinding and twisting apparatuses. The cylinders were shaped into a capstan shape having a minimum diameter of 10-mm using a precision grinding machine (Gel Consultants, Raleigh, NC). Measurements of the total cylinder length ( $L_{tot}$ ), length of curved section ( $L_{curve}$ ), upper cylinder radius ( $r_{total}$ ), and minimum radius ( $r_{min}$ ) were taken in order to calculate the geometry of the curved section. Figure 1 illustrates the capstan geometry.

Samples were twisted using a Haake 550 viscotester (Gebruder Haake GmbH, Karlsruhe, Germany) fitted with a fabricated apparatus (Truong and Daubert, 2000) that enables torsional measurement. The capstans were twisted at 0.045, 0.45, and 4.5 rpm, and three replications at each speed of each sample were made. These speeds correspond to strain rates of 0.0047, 0.047, and 0.47 s<sup>-1</sup>.

True shear stress ( $\sigma_t$ ) and true shear strain ( $\gamma_{t-true}$ ) were calculated at the time at fracture using the following relationships (Nadai, 1937; Diehl et al., 1979; Hamann, 1983):

$$\sigma_t = \frac{2KM}{\pi r_{min}^3}$$

$$\gamma_t = \frac{2K\phi_s}{\pi r_{min}^3 Q}$$

$$\gamma_{t-true} = \ln \left[ 1 + \frac{\gamma_t^2}{2} + \gamma_t \left( 1 + \frac{\gamma_t^2}{4} \right)^{1/2} \right]$$

where  $r_{min}$  is the minimum capstan radius, M is the torque (N m),  $\phi_s$  is the angular deformation of the curved section, K is the shape factor constant (equal to 1.08), and Q is the

curvature section constant (equal to  $8.45 \times 10^{-6} \text{ m}^{-3}$ ).

**Vane analysis.** The vane method was used to determine large strain and fracture properties of the cheeses. A 4-blade vane being 6-mm in diameter and 20-mm in height was attached to a Haake 550 viscotester (Gebruder Haake GmbH, Karlsruhe, Germany). Figure 2 illustrates the vane geometry.

Care was taken when lowering the vane into the cheese sample in order to maintain sample integrity. The vane was rotated at speeds of 0.045, 0.45, and 4.5 rpm; these speeds correspond to strain rates of 0.0047, 0.047, and  $0.47 \text{ s}^{-1}$ , allowing for comparison with torsion data. Vane shear stress ( $\sigma_v$ ) and apparent strain ( $\gamma_v$ ) were calculated using the following equations (Pamukcu and Suhayda, 1988; Steffe, 1996; Daubert et al., 1998):

$$\sigma_v = \frac{2M}{\pi d^3} \left( \frac{h}{d} + \frac{l}{6} \right)^{-1}$$

$$\Theta = \Omega t$$

$$\gamma_v = \frac{\Theta}{d_f/d - 1}$$

where M is the torque (N m), h is the vane height, d is the vane diameter,  $\Theta$  is the angular deformation at the vane edge,  $\Omega$  is the angular velocity, t is the time (s), and  $d_f/d$  is the ratio of the diameter of fractured area to the vane diameter, equal to 2.0 (Keentok et al., 1985).

**Statistical Analysis.** Simple linear regression analysis of the vane fracture stress versus the torsion fracture stress for all samples at all speeds was done using Sigma Plot (Version 6.10, SPSS, Inc., Chicago, IL).

## RESULTS AND DISCUSSION

### Sample Observations

Preparation of the Mozzarella samples for the torsion tests during the early stages of maturation (4 d and 10 d) proved to be problematic. Due to the fibrous nature of these cheeses, grinding these cheeses into the capstan shape was difficult. Upon further investigation, it was discovered that when the fibers were parallel to the upper radius, the grinding apparatus would carve “niches” at the minimum radius (see Figure 3 for pictorial representation). However, when the fibers were oriented perpendicular to the upper radius, problems in grinding ceased. Therefore, all samples tested were twisted with the fibers perpendicular to the upper radius.

In the torsion tests, the fractured surface of the capstan was slanted at approximately 45° indicating that the samples failed in tension.

### Fracture Parameters

Texture maps are plots of fracture strain and fracture stress. The textures of several materials can be compared by observing the materials’ relative fracture stresses and fracture strains (Lanier, 1986). The model of the texture map is given (Figure 4). Fracture stress and fracture strain using the torsion and vane methods to evaluate all of the cheeses are given for all three testing speeds in Figure 5. In the torsion tests, as the speed of the test increased, the resulting fracture stresses increased and fracture strain decreased. Increasing speed using the vane method resulted in slightly increased fracture stresses; little change in fracture strain was observed under these conditions. Additionally, as the speed of rotation increased, the error in the fracture stress measurement appeared to increase in the torsion test. When comparing the texture maps generated from the two methods, it was observed that the torsion

method resulted in higher stresses and strains than the vane results.

### **Comparison of Vane and Torsion Fracture Stress**

Fracture stress from both the vane and the torsion results were compared for all cheeses at all strain rates using simple linear regression (Figure 6). For the same cheeses, values for torsion fracture stress were approximately two times the values for vane fracture stress. However, the regression coefficient describing the fit of this data was lower than expected ( $R^2=0.661$ ). Previous unpublished research done at North Carolina State University, which examined mostly process and other cheeses, indicated that torsion fracture stress was 2.39 times higher than vane fracture stress ( $R^2=0.923$ ) (Truong and Daubert). Perhaps the more homogeneous nature of Process cheeses tested would account for the higher reported regression coefficient. Additionally, it was observed that at higher strain rates ( $0.47 \text{ s}^{-1}$ ), the data deviated from the aforementioned relationship. This also contributed to a less than expected regression coefficient.

## **CONCLUSIONS**

The fracture characterization of several cheeses was compared using the vane and torsion methods. It was found that torsion fracture stresses were ~2 times higher than vane fracture stresses.

## **ACKNOWLEDGMENTS**

We would like to thank Dairy Management, Inc. for funding this project, and we would like to acknowledge the continued support of the Southeast Dairy Foods Research Center.



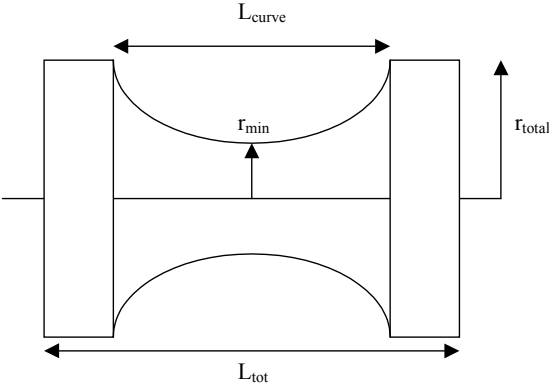
## REFERENCES

- Ak, M. M., and S. Gunasekaran. 1997. Anisotropy in tensile properties of Mozzarella cheese. *J. Food Sci.* 62:1031-1033.
- Benedito, J., R. Gonzalez, C. Rossello, and A. Mulet. 2000. Instrumental and expert assessment of Mahon cheese texture. *J. Food Sci.* 65:1170-1174.
- Bowland, E. L., and E. A. Foegeding. 1999. Factors determining large-strain (fracture) rheological properties of model processed cheese. *J. Dairy Sci.* 82:1851-1859.
- Breidinger, S. L., and J. F. Steffe. 2001. Texture map of cream cheese. *J. Food Sci.* 66:453-456.
- Breuil, P., and J. F. Meullenet. 2001. A comparison of three instrumental tests for predicting sensory texture profiles of cheese. *J. Texture Stud.* 32:41-55.
- Casiraghi, E., M. Lucisano, and C. Pompei. 1989. Correlation among instrumental texture, sensory texture and chemical composition of five Italian cheeses. *Ital. J. Food Sci.* 1:53-63.
- Chen, A. H., J. W. Larkin, C. J. Clark, and W. E. Irwin. 1979. Textural analysis of cheese. *J. Dairy Sci.* 62:901-907.
- Daubert, C. R., J. A. Tkachuk, and V. D. Truong. 1998. Quantitative measurement of food spreadability using the vane method. *J. Texture Stud.* 29:427-435.
- Diehl, K. C., and D. D. Hamann. 1979. Structural failure in selected raw fruits and vegetables. *J. Texture Stud.* 10:371-400.
- Drake, M. A., P. D. Gerard, V. D. Truong, and C. R. Daubert. 1999. Relationship between instrumental and sensory measurements of cheese texture. *J. Texture Stud.* 30:451-476.

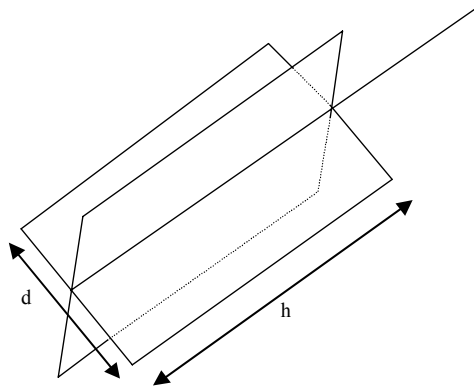
- Friedman, H. H., J. E. Whitney, and A. S. Szczesniak. 1963. The texturometer- a new instrument for objective texture measurement. *J. Food Sci.* 28:390-396.
- Green, M. L., R. J. Marshall, and B. E. Booker. 1985. Instrumental and sensory texture assessment and fracture mechanisms of Cheddar and Cheshire cheese. *J. Texture Stud.* 16:351-364.
- Hamann, D. D. 1983. Structural failure in solid foods. Pages 351-383 *in Physical Properties of Foods*. M. Peleg, and E. B. Bagley, ed. AVI Publishing Company, Inc., Westport, CT.
- Hort, J., and G. Le Grys. 2000. Rheological models of Cheddar cheese texture and their application to maturation. *J. Texture Stud.* 31:1-24.
- Jack, F. R., J. R. Piggott, and A. Paterson. 1993. Relationships between rheology and composition of Cheddar cheeses and texture as perceived by consumers. *Int. J. Food Sci. Technol.* 28:293-302.
- Kavanagh, G. M., and S. B. Ross-Murphy. 1998. Rheological characterization of polymer gels. *Prog. Polym. Sci.* 23:533-562.
- Keentok, M., J. F. Milthorpe, and E. O'Donovan. 1985. On the shearing zone around rotating vanes in plastic liquids: theory and experiment. *J. Non-Newtonian Fluid Mechan.* 17:23-35.
- Lanier, T. C. 1986. Functional properties of surimi. *Food Technol.* 40:107-114, 124.
- Lee, C. H., E. M. Imoto, and C. Rha. 1978. Evaluation of cheese texture. *J. Food Sci.* 43:1600-1605.
- Nadai, A. 1937. Plastic behavior of metals in the strain-hardening range. Part I. *J. Appl. Physics.* 8:205-213.

- Pamukcu, S., and J. Suhayda. 1988. Low-strain shear measurement using a triaxial vane device. Pages 193-208 *in* Vane Shear Strength Testing in Soils: Field and Laboratory Studies. Richards, A. F. ed. ASTM, Philadelphia, PA.
- Steffe, J. F. 1996. Rheological Methods in Food Process Engineering. Freeman Press, East Lansing, MI.
- Truong, V. D., and C. R. Daubert. 2000. Comparative study on large strain methods in assessing failure characterization of selected food gels. *J. Texture Stud.* 31:335-353.
- Truong, V. D., and C. R. Daubert. 2001. Textural characterization of cheeses using vane rheometry and torsion analysis. *J. Food Sci.* 66:716-721.
- Tunick, M. H., K. L. Mackey, P. W. Smith, and V. H. Holsinger. 1991. Effects of composition and storage on the texture of Mozzarella cheese. *Neth. Milk Dairy J.* 45:117-125.
- Tunick, M. H., E. L. Malin, P. W. Smith, J. J. Shieh, B. C. Sullivan, K. L. Mackey, and V. H. Holsinger. 1993. Proteolysis and rheology of low-fat and full-fat Mozzarella cheeses prepared from homogenized milk. *J. Dairy Sci.* 76:3621-3628.
- van Vliet, T., and P. Walstra. 1995. Large deformation and fracture behaviour of gels. *Faraday Discuss.* 101:359-370.

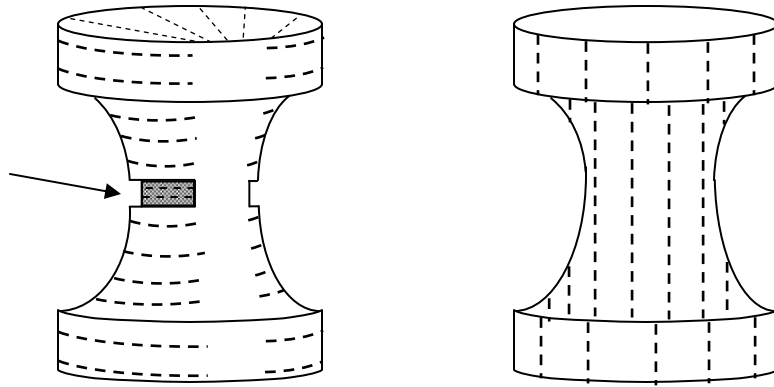
**FIGURES AND TABLES**



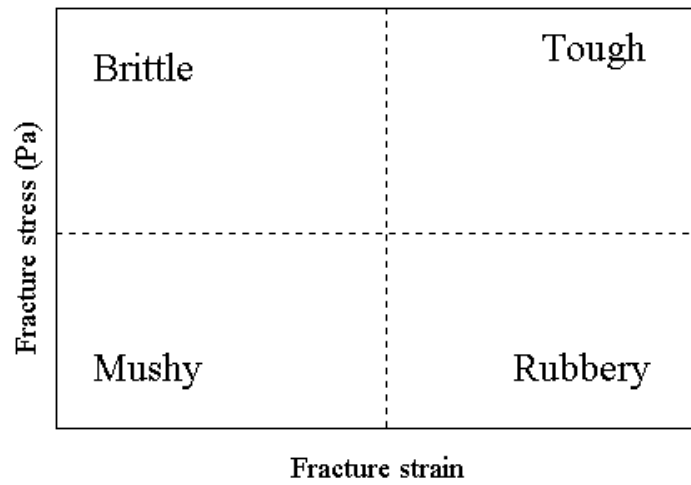
**Figure 1.** Capstan geometry used for torsional testing; Total cylinder length ( $L_{tot}$ ), Length of capstan curved section ( $L_{curve}$ ), Radius of upper edge of capstan ( $r_{total}$ ), Minimum radius of capstan curved section ( $r_{min}$ ).



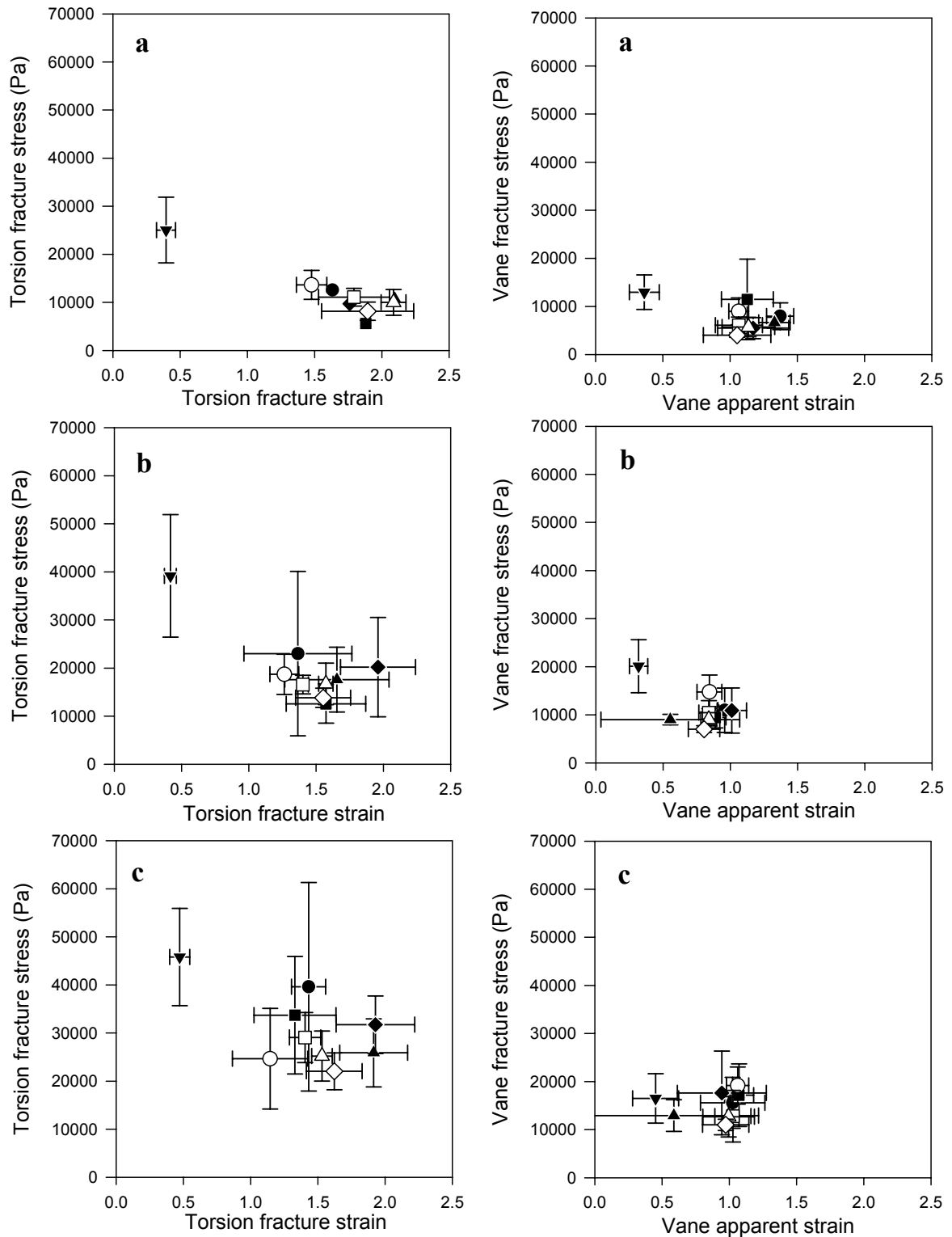
**Figure 2.** Geometry for four blade vane analysis; Vane diameter ( $d$ ), Vane height ( $h$ ).



**Figure 3.** Pictorial representation of fiber orientation in Mozzarella samples during torsion analysis. Dotted lines represent fiber orientation. Arrow indicates the “notch” that formed during capstan formation in capstans having horizontal fiber orientation.

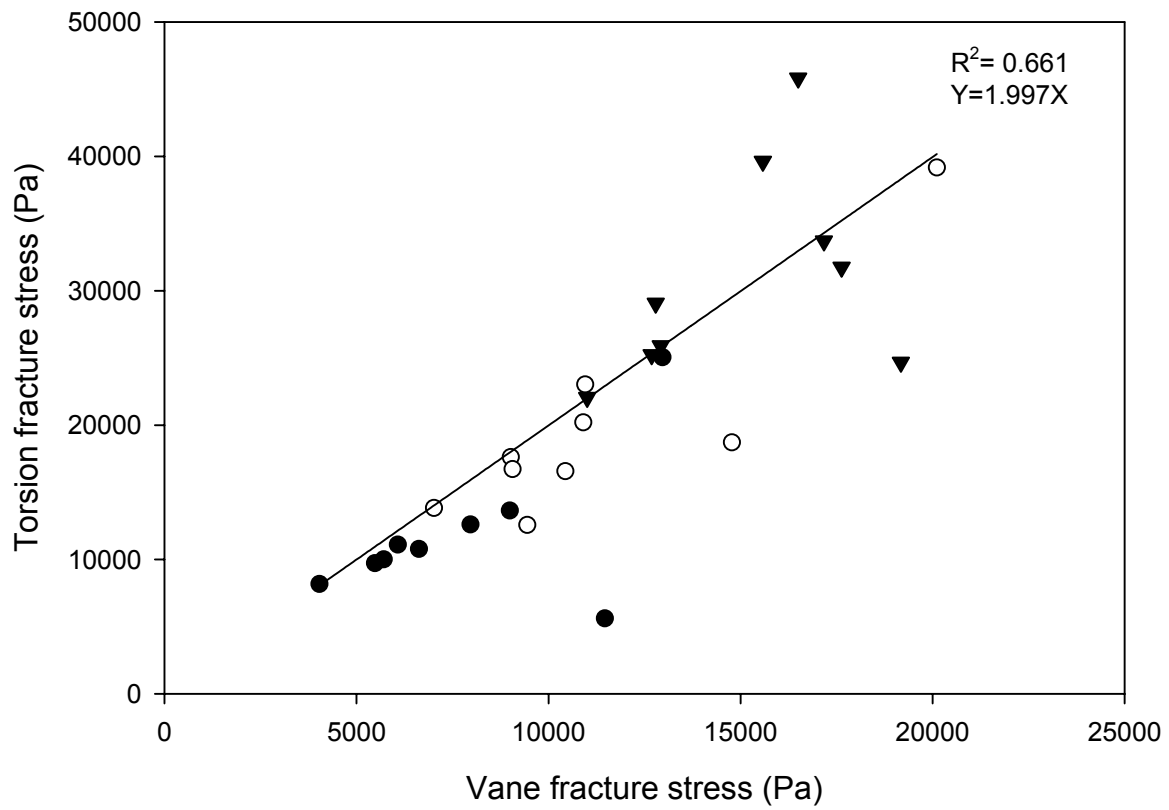


**Figure 4.** Modified texture map showing textural relationships of fracture stress and fracture strain values. (Based upon Lanier, 1986).



**Figure 5.** Vane and torsion parameters at strain rates of 0.0047 (a), 0.047 (b), and 0.47 (c) s<sup>-1</sup> for Mozzarella cheeses at 4d (●), 10 d (■), 17 d (▲), and 38 d (◆); Pizza cheeses at 4d (○), 10d (□), 17d (△); and 38 d (◇), and Process cheeses (▼).





**Figure 6.** Comparison of vane and torsion fracture stress for all cheeses at all ages at strain rates of 0.0047 (●), 0.047 (○), and 0.47 (▼) s<sup>-1</sup>.

**THE EFFECT OF FIBER ORIENTATION OF YOUNG MOZZARELLA CHEESES  
ON THE SENSORY PERCEPTION OF TEXTURE**

**J. A. Brown, E. A. Foegeding, and M. A. Drake**

Department of Food Science  
North Carolina State University

## ABSTRACT

Sensory properties were evaluated in Mozzarella cheeses to see if fiber orientation affected the textural perception. Methodology was developed to prepare the samples so that different fiber orientations could be evaluated without panel knowledge of differences in preparation among samples. No differences in any of the sensory terms were found between samples tested having the fibers oriented parallel to the force applied and samples tested having fibers perpendicular to the force applied.

**(Key Words:** Mozzarella, fiber orientation, texture, sensory)

## INTRODUCTION

Mozzarella cheese has a unique texture primarily due to the characteristic fibrous nature of the material. This texture results from a specific step during manufacture in which the drained curds are immersed into hot water and stretched. The hot water acts as a plasticizer, forming the curd into a pliable mass. The curds are stretched and kneaded which causes the protein network to have a specific orientation, resulting in the characteristic texture. When Mozzarella is torn, as in during the consumption of string cheese, the orientated protein matrix breaks and the water and fat in the matrix is expelled (Taneya et al., 1992).

The fibrous nature of Mozzarella has been explored using tensile methods. Ak and Gunasekaran (Ak and Gunasekaran, 1997) suggested that the kneading process forms orientated protein fibers and is responsible for Mozzarella behaving in an anisotropic nature. They found that fracture toughness, stress, and strain were dependent upon the direction of the protein fibers relative to the applied tensile force. The samples tested with the fibers

parallel to the applied tensile force required more stress to fracture, had a higher fracture strain, and had an overall greater toughness than the samples tested with the fibers perpendicular to the applied tensile force. They hypothesized that when the sample is subjected to parallel stress (pulled in the same direction as the protein alignment), all protein fibers must be broken for fracture to occur. However, when tensile stress is applied to the sample perpendicular to the fibers, interfacial bonds between the protein, fat, and serum control failure. The group concluded that protein fibers in Mozzarella cheese are stronger than interfacial bonds.

Little is known about the ability of humans to detect differences in sample texture based upon fiber orientation. The objective of this research was to see if humans could detect differences in sensory texture between Mozzarella samples having different fiber orientation. Such work would prove beneficial in developing sensory methodology for determining Mozzarella texture.

## **MATERIALS AND METHODS**

### **Material Description**

Mozzarella cheeses were tested at 4, 10, 17, and 38 d of age on two different occasions and were manufactured by Alto Dairy Cooperative (Waupun, WI). The cheeses were collected immediately following manufacture and shipped to North Carolina State University using temperature-controlled packaging material to ensure that the cheeses remained at appropriate temperatures during shipping; all aging occurred at North Carolina State University. Cheeses were stored at 4° C in 4.5 kg blocks in Cryovac B series, vacuum-sealed bags. Approximately 3-cm of the outer rind of the cheeses was discarded immediately

prior to sample preparation. The cheeses were allowed to temper to room temperature before testing.

### **Sensory Analysis**

Descriptive sensory analysis techniques were used to describe and characterize the human perception of cheese texture. A panel of 15 people received approximately 10 hours of training encompassing evaluation techniques, texture term definitions, and use of reference scales. Cheeses were evaluated using hand, mouth, and residual techniques. The terms used to define texture are outlined in Table 1 (Drake et al., 1999; Gwartney et al., 2002). The terms were evaluated in the order listed in the table. The panel developed a 15-point product-specific reference scale for each term, with a score of 15 indicating that the sample was high in the attribute (see Table 1). During training, the panel was presented cheeses having textural extremes for each term representing the anchors of each scale. The panel was then presented with more common, well-known cheeses, and through panel consensus, scores were assigned to these cheeses, thereby completing the reference scales. Through training and group discussion, panel variation was minimized.

At each sample evaluation session, three to six cheese samples were evaluated. Each cheese sample was cut into 1.27-cm<sup>3</sup> cubes and marked with food grade ink (Private Label Products Inc., Fair-Lawn, NJ) to designate the “top” of the cube. The panelists were instructed to perform the hand and first bite evaluations with the marking facing either their index finger or their upper molars. The panelists did not know the purpose of the test (i.e. they were not aware that the fiber orientation within the cheeses was being tested) and this marking allowed for control of the direction of fibers without compromising experimental protocol. Figure 1 illustrates the sample orientation and evaluation methods used.

Each panelist was given four cubes of cheese per sample. The samples were presented at room temperature in 2-oz plastic sample cups sealed with plastic lids (Sweetheart Cup Company Inc., Owings Mills, MD) to deter moisture loss, and samples were identified by a random 3-digit numerical code. The testing occurred in individual booths under normal lighting conditions. Panelists were given appropriate references, prepared in the same manner as the sample at each session, and a warm-up sample prior to sample evaluation. The warm-up sample was the same each evaluation session and was used extensively during training. Panelists were also given water and napkins for mouth and hand cleansing and were instructed to expectorate all samples in order to measure residual mouthfeel. Testing occurred at the same time each day, and the samples were randomized so that each age of each cheese was evaluated three times over a two-day period.

### **Statistical Analysis**

Analysis of variance (PROC MIXED) was done on the sensory terms using the SAS statistical software package (Version 8.2, SAS Institute, Inc., Cary, NC); significance was established at  $P \leq 0.05$ .

## **RESULTS AND DISCUSSION**

Analysis of variance revealed that there were no significant differences between the Mozzarella cheeses sampled with the fibers oriented parallel to the force being applied and the cheeses sampled with the fibers oriented perpendicular to the force being applied in any of the terms tested.

## **CONCLUSIONS**

Humans were not able to detect differences between Mozzarella samples having different fiber orientation. Though these differences may be detectable using mechanical devices, human sensitivity to these differences was not apparent.

## **ACKNOWLEDGMENTS**

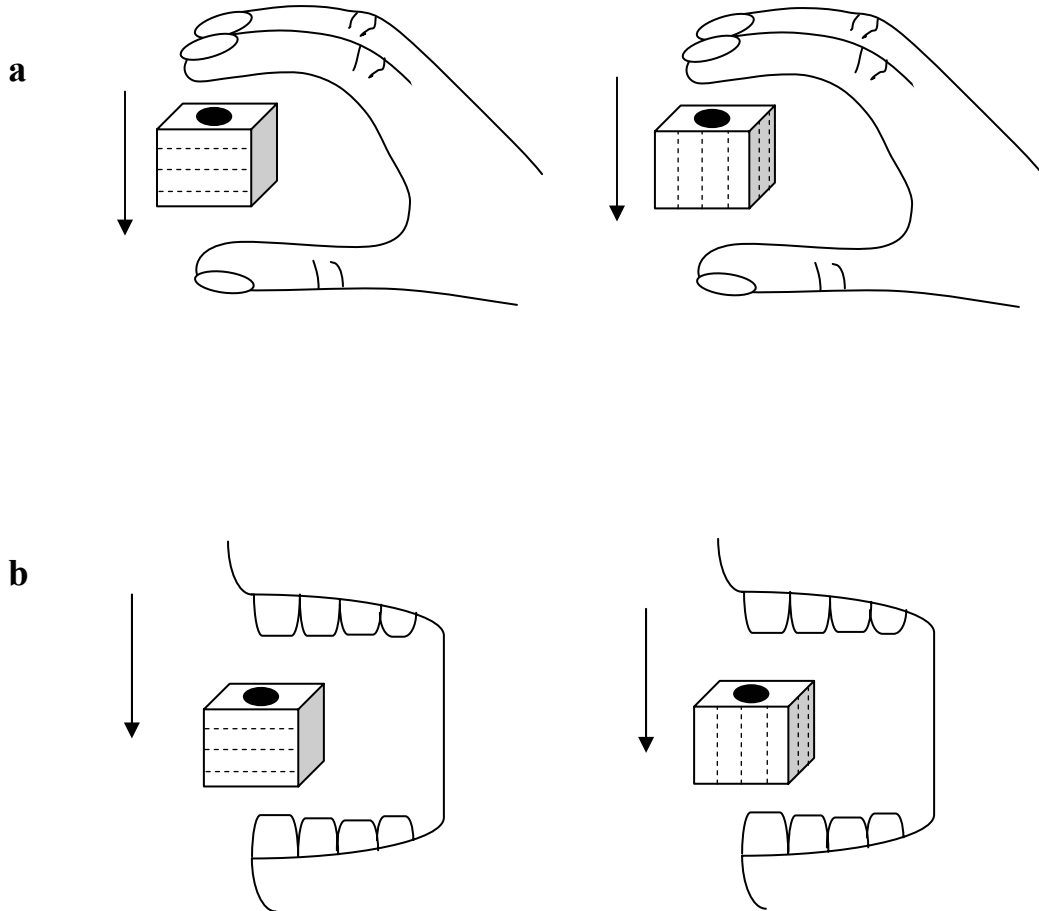
We are grateful for the support from the Southeast Dairy Foods Research Center and Dairy Management, Inc. We would also like to thank those individuals whom dedicated their time to participate in sensory panels.

## REFERENCES

- Ak, M. M., and S. Gunasekaran. 1997. Anisotropy in tensile properties of Mozzarella cheese. *J. Food Sci.* 62:1031-1033.
- Drake, M. A., P. D. Gerard, and G. V. Civille. 1999a. Ability of hand evaluation versus mouth evaluation to differentiate texture of cheese. *J. Sens. Stud.* 14:425-441.
- Gwartney, E. A., E. A. Foegeding, and D. K. Larick. 2002. The texture of commercial full-fat and reduced-fat cheese. *J. Food Sci.* 67:812-816.
- Taneya, S., T. Izutsu, T. Kimura, T. Shioya, W. Buchheim, P. S. Kindstedt, and D. G. Pechak. 1992. Structure and rheology of string cheese. *Food Struct.* 11:61-71.



## FIGURES AND TABLES



**Figure 1.** Pictorial representation of evaluation method for hand evaluated (a) and first bite evaluated (b) sensory terms describing Mozzarella texture. Dotted lines represent fiber orientation. Black dot represents marking on the top of the cube to indicate to panelists how to orient sample cube in hand/mouth. Arrows represent direction of force.

**Table 1.** Language used to evaluate cheese texture perception; evaluation techniques, term definitions, and references are given.

<b>Term (Abbreviation)</b>	<b>Definition</b>	<b>Technique</b>	<b>Reference</b>
Hand Firmness	The amount of force required to completely compress the sample.	Press completely through the sample using the thumb and first two fingers.	3= Process cheese <sup>1</sup> 7= Muenster <sup>2</sup> 10= Sharp Cheddar <sup>3</sup> 14= Parmesan <sup>4</sup>
Hand Springiness	The total amount of recovery of the sample.	Press the sample between the thumb and first two fingers until it is depressed 30%.	1= Parmesan 4= Process cheese 7= Sharp Cheddar 13= Muenster
Hand Rate of Recovery	The rate at which the sample recovers (i.e. the speed at which the sample returns to its original shape).	Press the sample between the thumb and first two fingers until it is depressed 30%.	1= Feta <sup>5</sup> 4= Process cheese 7= Muenster
First Bite Firmness	The amount of force required to completely bite through the sample.	Completely bite through the sample using the molars.	3= Process cheese 7= Muenster 10= Sharp Cheddar 14= Parmesan
First Bite Fracturability	The amount of fracturability in the sample after biting.	Completely bite through the sample using the molars.	1= Process cheese 5= Sharp Cheddar 14= Feta
Chewdown Degree of Breakdown	The amount of breakdown that occurs in the sample as a result of mastication (i.e. the amount of meltability or dissolvability).	Chew the sample 5 times and evaluate the chewed mass.	1= Parmesan 10= Sharp Cheddar 14= Process cheese
Chewdown Cohesiveness	The degree to which the chewed mass holds together.	Chew the sample 5 times and evaluate the chewed mass.	1= Parmesan 3= Feta 9= Muenster 14= Process cheese
Chewdown Adhesiveness	The degree to which the chewed mass sticks to mouth surfaces.	Chew the sample 5 times and evaluate the chewed mass.	1= Parmesan 7= Muenster 12= Feta 14= Process cheese
Chewdown Smoothness of Mass	The degree to which the chewed mass surface is smooth (i.e. evaluation for gritty or grainy particles).	Chew the sample 5 times and evaluate the chewed mass.	1= Parmesan 3= Feta 8= Muenster 14= Process cheese
Residual Smoothness of Mouth Coating	The degree of smoothness felt in the mouth after expectorating the sample.	Chew the sample 5 times, expectorate, and evaluate the residual in the mouth.	1= Parmesan 5= Feta 10= Muenster 14= Process cheese

<sup>1</sup>Process cheese: Velveeta brand 907-g loaf (Kraft Foods North America; Glenview, IL)

<sup>2</sup>Muenster: Harris Teeter brand (Harris Teeter; Matthews, NC)

<sup>3</sup>Sharp Cheddar: Kraft brand 227-g block (Kraft Foods; Glenview, IL)

<sup>4</sup>Parmesan: Kraft brand 113-g triangle (Kraft Foods; Glenview, IL)

<sup>5</sup>Feta: Athenos brand 227-g block (Churny Company, Inc.; Weyauwega, WI)

**CHARACTERIZATION OF YOUNG CHEESES USING DIFFERENTIAL  
SCANNING CALORIMETRY**

**J. A. Brown and E. A. Foegeding**

Department of Food Science  
North Carolina State University

## **ABSTRACT**

The thermal properties of maturing cheeses were explored using differential scanning calorimetry (DSC). Mozzarella and Pizza cheeses were tested at 4, 10, 17, and 38 d of age; Process cheese was tested at 4 d of age. Two different heating schemes were used to determine if glass transitions occur in these cheeses and to characterize melting behavior. Glass transition temperatures were determined in the Process cheese. The heating profiles at elevated temperatures (i.e. during melting) were similar in all cheeses at all ages. It is likely that the transitions seen during melting are due to phase changes in certain lipids within the cheese.

## **INTRODUCTION**

Differential scanning calorimetry (DSC) is a method that measures heat absorption or liberation that occurs when a material experiences changes in physical state (as in melting) or when chemical reactions occur. It is one of the most widely used of the thermal analysis techniques due to the extensive variety of data that can be collected including: glass transition temperatures, crystallization, solid-solid transitions, fusion, dehydration, denaturation, transition/reaction enthalpies, heat capacity measurements, purity determination, and degree of crystallinity (Lund, 1983).

Differential scanning calorimetry has been used extensively in food research, including cheese. This technique was used to differentiate natural and imitation (made with caseinates) Mozzarella cheeses (Tunick, 1989). They found that with increasing caseinate concentration, the enthalpy of transition ( $\Delta H$ ) decreased. They hypothesized that the

emulsifying properties of the caseinate prevented portions of the fat from crystallizing; less fat would be available to melt causing smaller melting transitions and a lower  $\Delta H$ .

The objective of this research was to use differential scanning calorimetry to determine if differences existed among melting behaviors of different cheeses as they matured.

## **MATERIALS AND METHODS**

### **Material Description**

The thermal properties of three cheese varieties were observed: Mozzarella, Pizza cheese, and High melt process cheese (referred to as Process cheese). On two different occasions, all cheeses were manufactured by cheese makers and collected at the time of manufacture. Mozzarellas were manufactured by Alto Dairy Cooperative (Waupun, WI); Pizza cheeses were crafted by Meister Cheese Company (Muscodia, WI); and Process cheeses were made by Kraft (Glenview, IL). Cheeses were shipped to North Carolina State University using temperature-controlled packaging materials to ensure that the cheeses remained at appropriate temperatures during shipping. The cheeses were shipped immediately following manufacture, and all aging occurred at North Carolina State University. Cheeses were stored at 4° C in 4.5 kg blocks in Cryovac B series, vacuum-sealed bags. Testing of the Mozzarella and Pizza cheeses occurred at 4, 10, 17, and 38 d of age; Process cheese was tested at 4 d of age. Approximately 3-cm of the outer rind of the cheeses was discarded immediately prior to sample preparation.

### **Differential Scanning Calorimetry**

The thermal behavior of the cheeses was observed using a Perkin-Elmer 7 Series

Differential Scanning Calorimeter (Norwalk, CT) which utilized Pyris software (version 3.81). The calorimeter had an intracooler refrigeration unit and dry box. Prior to sample testing, the instrument was calibrated using two metals having known onset temperatures: indium (onset temperature of 15.6°C) and dodecane (onset temperature of -9.6°C).

The cheeses were portioned into 60 to 70-mg samples and sealed in large volume stainless steel pans (Perkin-Elmer; Norwalk, CT). Nitrogen was used as the purge gas and flowed at a rate of 40 ml/min; nitrogen was also used to flush the dry box. To determine the glass transition of the cheeses, the samples were heated from -70 to 30 °C at a rate of 5°C/min. To determine the melting behavior of the cheeses, the samples were heated from 2 to 100°C at a rate of 5°C/min. Two tests were done for each replication of each treatment.

## **RESULTS AND DISCUSSION**

### **Glass Transition**

The results of heating from -70 to 30°C are given in Table 1. Process cheese showed a glass transition, at around -42°C. The second replication of Mozzarella showed a very small peak at around -50°C for all days tested. However, it is doubtful that these are indications of glass transitions due to the small change in enthalpy ( $\Delta H=0.1$  J/g for all samples).

### **Melting Behavior**

The onset temperature is the tangent to the leading line of the peak and describes the temperature in which a component begins to melt. The half-melt temperature is the point where half of the substance is melted and is usually described as the melting point of the

component. Enthalpy ( $\Delta H$ ) is the area under the curve and describes the amount of energy used to melt the component.

These parameters were observed during the heating program from 2 to 100°C, for all cheeses at all times; the thermal transitions are given in Table 2. For all cheeses at all times, two peaks were observed, having melting temperatures around 17°C and 33°C. Similar DSC parameters have been reported for Mozzarella cheese (Tunick, et al., 1989). Onset temperature, melting temperature, and  $\Delta H$  were similar for all cheeses at ages for these two peaks. Additionally, a third, smaller peak ( $\Delta H \leq 0.7$  J/g) was observed in the second replication of Mozzarella. It is likely that these peaks represent two different fatty acids changing phases in these cheeses. The similarity in shape and position of the peaks in cheeses as they age is to be expected since during the ripening of cheeses, little changes occur in the lipid partition. It is likely that in very old cheeses, changes in lipid crystalline structure could occur, however, given the young nature of these cheeses, such changes were not expected.

## CONCLUSIONS

Little differences were observed in the thermal behavior of different varieties of cheese or in the behavior of cheeses as they aged. Though, differential scanning calorimetry is a useful tool to determine the overall melting behavior of cheese, it was not useful to differentiate these cheeses by variety or to determine transitions that may occur during early stages of aging.

## **ACKNOWLEDGMENTS**

We are grateful for the support from the Southeast Dairy Foods Research Center and Dairy Management, Inc. We would also like to thank Penny Amato for her technical expertise.



## REFERENCES

- Lund, D. B. 1983. Applications of differential scanning calorimetry in foods. Pages 125-143  
*in* Physical Properties of Foods. M. Peleg, ed. AVI Publishing Co., Inc., Westport,  
CT.
- Tunick, M. H., J. J. Basch, B. E. Maleeff, J. F. Flanagan, and V. H. Holsinger. 1989.  
Characterization of natural and imitation Mozzarella cheeses by differential scanning  
calorimetry. *J. Dairy Sci.* 72:1976-1980.

## FIGURES AND TABLES

**Table 1.** Onset and glass transition temperatures ( $T_g$ ) for maturing cheeses. Enthalpy changes ( $\Delta H$ ) are also given.

Cheese	Replication	Age (d)	Onset	$T_g$	$\Delta H$ (J/g)
			Temperature (°C)	Temperature (°C)	
Mozzarella	1	4	*	*	*
		10	*	*	*
		17	*	*	*
		38	*	*	*
	2	4	-47	-51.7	0.1
		10	-46.5	-50	0.1
		17	-47.8	-50.8	0.1
		38	-46.9	-50.1	0.1
Pizza	1	4	*	*	*
		10	*	*	*
		17	*	*	*
		38	*	*	*
	2	4	*	*	*
		10	*	*	*
		17	*	*	*
		38	*	*	*
Process	1	4	-46.6	-43.2	0.6
	2	4	-42.2	-41.5	0.4

\*Denotes that no glass transition was determined for the sample.

**Table 2.** Onset and melting temperatures for maturing cheeses. Enthalpy ( $\Delta H$ ) is also given.

Cheese	Replication	Age (d)	Peak 1			Peak 2			Peak 3		
			Onset Temperature (°C)	Half Melt (°C)	$\Delta H$ (J/g)	Onset Temperature (°C)	Half Melt (°C)	$\Delta H$ (J/g)	Onset Temperature (°C)	Half Melt (°C)	$\Delta H$ (J/g)
Mozzarella	1	4	12.3	16.9	2.2	25	33.4	3.8	*	*	*
		10	12.7	17.5	2.4	25.3	30.1	3.6	*	*	*
		17	11.9	17.6	2.9	26.8	34.8	2.4	*	*	*
		38	12.4	17.6	3	27.2	34.4	2.5	*	*	*
	2	4	13.1	17.2	2.1	25.9	33	2.6	*	*	*
		10	11.6	16.9	2.5	24.5	29	3.8	*	*	*
		17	10.9	17.2	3.1	27.6	34	2.5	*	*	*
		38	11.3	17.1	2.4	27.5	34	2	*	*	*
Pizza	1	4	13.1	17.6	3.1	25.6	32.5	4.9	47	53.9	0.5
		10	12.8	17.3	4	24.5	30.4	4.9	48.4	52.3	0.7
		17	10.2	17.6	6.1	25.3	32.8	4.5	57.1	59.8	0.2
		38	14.7	18.3	2.5	28.2	36.7	2.9	55.8	56.9	0.2
	2	4	12.8	17.2	2.1	25.9	33	2.6	*	*	*
		10	10.5	16.9	2.5	24.5	29	3.8	*	*	*
		17	12.1	17.2	3.1	27.6	34	2.5	*	*	*
		38	11	17.1	2.4	27.5	34	2	*	*	*
Process	1	4	13.4	18.3	3.5	26.5	33.8	5.2	*	*	*
	2	4	12.8	17.5	3.8	29.7	35.7	3.1	*	*	*

\*Denotes cheeses that did not have a third peak measured.