

## ABSTRACT

**MARZEC, JACQUELINE MONNETTE.** Antioxidant defense: Effects of an NRF2 ARE polymorphism on the activation of phase II enzymes. (Under the direction of Steven Kleeberger.)

The purpose of the research put forth in this thesis has been to critically evaluate the functional effects of a single nucleotide polymorphism in the antioxidant response element (ARE) of *NRF2*. NRF2 is a transcription factor that regulates numerous antioxidants in response to oxidative stress, and we believe polymorphisms within the ARE may impact both transcription and translation of downstream antioxidants. Initial studies focused on quantitative differences in NRF2 expression between ARE constructs with and without mutation using transient transfection assays as well as diminished NRF2:ARE binding by gel shift analysis. Effects of decreased function were further analyzed using lymphoblast cell lines with naturally occurring *NRF2* ARE mutations (wildtype, ARE heterozygote and ARE variant) exposed to oxidative stress. Differences in mRNA expression levels of *NRF2* and downstream antioxidants were assessed by reverse transcriptase PCR and quantitative real-time PCR, and protein level changes were analyzed by western blot.

Studies showed that *NRF2* function was decreased with mutation to the ARE and NRF2:ARE binding was diminished in the presence of variant alleles. Furthermore, transcription of *NRF2* and several downstream antioxidants (*NQO1*, *HO1* and *GPx2*) was significantly upregulated in heterozygotes with one copy of the variant allele during serum starvation and following exposure to several oxidative stress agents [hyperoxia (95% oxygen) and lipopolysaccharide]. However, increased mRNA transcripts did not directly correlate with protein levels. Nonetheless, we did observe differential protein expression between *NRF2* genotypes for NRF2, the accessory protein small Maf, as well as ARE-bearing downstream antioxidants (NQO1, HO1, GPx2 and GSR). Furthermore, ratios of NRF2:Maf of 1:2 or 1:3 resulted in decreased HO1, GPx2 and GSR expression in most cases, suggesting the quantitative balance between NRF2 and small Maf proteins may regulate binding to ARE target genes. The consequences of these functional differences are likely to impact the cellular response to oxidative stress.

**Antioxidant defense: Effects of an NRF2 ARE polymorphism on the  
activation of phase II enzymes**

**By**

**JACQUELINE MONNETTE MARZEC**

A thesis submitted to the Graduate Faculty of  
North Carolina State University in partial  
fulfillment of the requirements for the  
Degree of Master of Science

**STRUCTURAL AND MOLECULAR BIOCHEMISTRY**

**Raleigh**

2006

**Approved by**

---

Co-chair of advisory committee

---

Co-chair of advisory committee

## **DEDICATION**

This thesis is dedicated to my husband who has supported me throughout this journey. His love and compassion have been unending, despite numerous weekends spent looking at the back of my head while I wrote my thesis. Without his devotion and encouragement I would have never taken on this endeavor. Thank you!

## **BIOGRAPHY**

Jacqui is the daughter of Barb and Doug Dewey. After graduating Chapel Hill High School, she attended the University of North Carolina at Chapel Hill and majored in chemistry. At UNC she participated in the professional chemistry fraternity Alpha Chi Sigma and sang in the Glee Club in her spare time.

After graduating college, she worked for several biotechnology companies as an analytical chemist. Many of her positions required strong genetics training, so she cross-trained herself in genetics. She took a position as a biologist at the NIEHS studying the gene-environment effects of lung diseases under the mentorship of Steve Kleeberger. The position was challenging, and Jacqui began to integrate her chemistry and genetics training into her research projects. Once she started writing manuscripts on her research she realized the scope of her knowledge was limited and decided it was time to apply for a higher degree.

Her dual interests in chemistry and genetics made selecting a program especially easy, and she applied for a masters program at NC State in the Department of Structural and Molecular Biochemistry. Working full-time at the NIEHS while going to class, doing research and writing a thesis has certainly been a challenge, but as she nears the completion of her degree, she wouldn't change it for the world.

## TABLE OF CONTENTS

<b>LIST OF TABLES</b> .....	v
<b>LIST OF FIGURES</b> .....	vi
<b>Literature Review</b> .....	1
Introduction.....	2
Oxidant-mediated injuries.....	4
Identification of the antioxidant response element (ARE) .....	5
NRF2 activation and regulation .....	6
ARE-bearing genes .....	8
Objectives of Work.....	9
References.....	13
<b>Chapter 1</b> .....	16
<b>Identification of ARE variant and functional studies</b> .....	16
Introduction.....	18
Materials and Methods.....	20
Sequencing analysis .....	20
Reporter Gene Assays.....	21
Electrophoretic Mobility Shift Assay (EMSA).....	22
Statistical analysis.....	23
Results and Discussion .....	23
SNP discovery.....	23
SNP function.....	23
Summary .....	26
References.....	34
<b>Chapter 2</b> .....	36
<b>Effects of the <i>NRF2</i> ARE polymorphism on downstream antioxidant transcription</b> ....	36
Introduction.....	38
Materials and Methods.....	41
In vitro techniques and exposures.....	41
RNA isolation and cDNA synthesis .....	42
Semi-quantitative RT-PCR analysis of gene expression .....	42

Quantitative real-time RT-PCR analysis .....	42
Statistical analysis.....	43
Results and Discussion .....	43
Hyperoxia.....	43
Lipopolysaccharide.....	44
Butylated hydroxytoluene.....	45
Summary.....	46
References.....	62
<b>Chapter 3 .....</b>	<b>65</b>
<b>Effects of the <i>NRF2</i> ARE polymorphism on antioxidant protein expression .....</b>	<b>65</b>
Introduction.....	67
Materials and Methods.....	70
In vitro techniques and oxidative stress exposures .....	70
Sequence verification of antioxidant AREs.....	71
Protein isolation and characterization.....	71
Western blot analysis .....	71
Analysis.....	72
Results and Discussion .....	72
Hyperoxia.....	72
Lipopolysaccharide.....	74
Butylated hydroxytoluene.....	76
Summary .....	77
References.....	89
<b>Summary.....</b>	<b>91</b>

## LIST OF TABLES

<b>Table 1.</b> Consensus sequences for antioxidant response elements (AREs) and bZIP transcription factors involved in oxidative stress.....	10
<b>Table 2.</b> NRF2 primers for promoter region polymorphisms, as well as electrophoretic mobility shift assay (EMSA) oligonucleotides.....	28
<b>Table 3.</b> Allelic frequencies of <i>NRF2</i> promoter polymorphisms in four ethnic groups.....	29
<b>Table 4.</b> Semi-quantitative RT-PCR and quantitative real-time SYBR primers for mRNA expression analysis.....	49
<b>Table 5.</b> Antioxidant primers for ARE consensus sequence verification.....	80
<b>Table 6.</b> Antibodies and dilutions used for Western blot analysis.....	81
<b>Table 7.</b> Ratio of NRF2:small Maf in the activating complex.....	82

## LIST OF FIGURES

### Literature Review

<b>Figure 1.</b> Domain structure and function of <i>Nrf2</i> .....	11
<b>Figure 2.</b> Transcription factors recruited to the ARE under homeostasis or during oxidative stress conditions.....	12

### Chapter 1

<b>Figure 1.</b> Identification of polymorphisms in <i>NRF2</i> .....	30
<b>Figure 2.</b> Representative electropherograms of <i>NRF2</i> promoter polymorphisms between –656 to –614 (reverse strand shown).....	31
<b>Figure 3.</b> <i>NRF2</i> promoter polymorphisms decrease functional activity. ....	32
<b>Figure 4.</b> Electrophoretic mobility shift assays (EMSA) to evaluate effects of the –617 polymorphism on protein-DNA complex formation. ....	33

### Chapter 2

<b>Figure 1.</b> mRNA expression of polymorphic <i>NRF2</i> -617 cells exposed to hyperoxia (95% O <sub>2</sub> ) for 0, 4 and 8 hours.....	50
<b>Figure 2.</b> mRNA expression of polymorphic <i>NRF2</i> -617 cells exposed to hyperoxia (95% O <sub>2</sub> ) for 0, 4 and 8 hours.....	51
<b>Figure 3.</b> mRNA expression of polymorphic <i>NRF2</i> -617 cells exposed to hyperoxia (95% O <sub>2</sub> ) for 0, 0.5, 1 and 2 hours.....	52
<b>Figure 4.</b> mRNA expression of polymorphic <i>NRF2</i> -617 cells exposed to hyperoxia (95% O <sub>2</sub> ) for 0, 0.5, 1 and 2 hours.....	53
<b>Figure 5.</b> mRNA expression of polymorphic <i>NRF2</i> -617 cells exposed to lipopolysaccharide (LPS) for 0, 3 and 6 hours.....	54
<b>Figure 6.</b> mRNA expression of polymorphic <i>NRF2</i> -617 cells exposed to lipopolysaccharide (LPS) for 0, 3 and 6 hours.....	55
<b>Figure 7.</b> mRNA expression of polymorphic <i>NRF2</i> -617 ARE cells exposed to lipopolysaccharide (LPS) for 0, 0.5, 1 and 2 hours. ....	56
<b>Figure 8.</b> mRNA expression of polymorphic <i>NRF2</i> -617 cells exposed to lipopolysaccharide (LPS) for 0, 0.5, 1 and 2 hours.....	57

<b>Figure 9.</b> mRNA expression of polymorphic <i>NRF2</i> -617 cells exposed to butylated hydroxytoluene (BHT) for 0, 8 and 24 hours. ....	58
<b>Figure 10.</b> mRNA expression of polymorphic <i>NRF2</i> -617 cells exposed to butylated hydroxytoluene (BHT) for 0, 8 and 24 hours. ....	59
<b>Figure 11.</b> mRNA expression of polymorphic <i>NRF2</i> -617 cells exposed to butylated hydroxytoluene (BHT) for 0, 0.5, 1 and 2 hours. ....	60
<b>Figure 12.</b> mRNA expression of polymorphic <i>NRF2</i> -617 cells exposed to butylated hydroxytoluene (BHT) for 0, 0.5, 1 and 2 hours. ....	61

### Chapter 3

<b>Figure 1.</b> Protein expression of polymorphic <i>NRF2</i> -617 cells exposed to hyperoxia (> 95% oxygen) for 0, 4 and 8 hours. ....	83
<b>Figure 2.</b> Protein expression of polymorphic <i>NRF2</i> -617 cells exposed to hyperoxia (> 95% oxygen) for 0, 0.5, 1 and 2 hours. ....	84
<b>Figure 3.</b> Protein expression of polymorphic <i>NRF2</i> -617 cells exposed to lipopolysaccharide (LPS) for 0, 3 and 6 hours. ....	85
<b>Figure 4.</b> Protein expression of polymorphic <i>NRF2</i> -617 cells exposed to lipopolysaccharide (LPS) for 0, 0.5, 1 and 2 hours. ....	86
<b>Figure 5.</b> Protein expression of polymorphic <i>NRF2</i> -617 cells exposed to butylated-hydroxytoluene (BHT) for 0, 8 and 24 hours. ....	87
<b>Figure 6.</b> Protein expression of polymorphic <i>NRF2</i> -617 cells exposed to butylated hydroxytoluene (BHT) for 0, 0.5, 1 and 2 hours. ....	88

## Literature Review

## Introduction

Molecular oxygen ( $O_2$ ) is vital for cellular processes in living organisms and composes approximately 22% of the earth's atmosphere. Under normal physiologic conditions the majority of oxygen consumed by cells is degraded to water by the cytochrome oxidase system, avoiding the production of free radicals. However, as a natural consequence of oxygen metabolism, a small portion of molecular oxygen is converted to superoxide ( $O_2^{\cdot-}$ ) by the electron transport chain of the mitochondria, or to additional reactive species [i.e. hydrogen peroxide ( $H_2O_2$ ) or hydroxyl radical ( $OH^{\cdot}$ )] in other cellular compartments.

Reactive oxygen species (ROS) may originate from cellular metabolic processes such as oxidative phosphorylation, activation of inflammatory cells, protective cytotoxic processes, or may be introduced via toxic extracellular compounds such as ingested foods and xenobiotics. Accumulation of ROS can cause membrane damage, tissue degeneration, DNA damage, mutagenesis, cellular transformation and apoptotic cell death. Cell survival depends on the ability to detoxify these compounds and restore homeostasis.

An intricate balance exists between oxidative load and detoxification of ROS to maintain reduction-oxidation (redox) equilibrium within the cellular milieu. Cellular defense systems exist that maintain redox balance in the body. Reactive intermediates either react spontaneously with macromolecules and are scavenged by antioxidants [i.e. glutathione reductase (GSR), glutathione peroxidase (GPx), NAD(P)H: quinone oxidoreductase 1 (NQO1), superoxide dismutase (SOD)], or are scavenged directly by soluble and insoluble vitamins [i.e. ascorbic acid,  $\alpha$ -tocopherol] or oxidant-related enzymes [i.e. heme-oxygenase 1 (HO1)] and converted to less detrimental by-products. ROS oxidize nucleic acids, proteins and lipids, causing damage to tissues and cellular components. An overabundance of oxidants combined with impaired antioxidant defense enhances susceptibility to oxidative stress. Free radical production has been implicated in the development of cancer, progression of neurodegenerative disorders, lung disease and aging.

As the major interface with the environment, the lung is routinely exposed to a variety of ROS generated during respiration. Rich in vitamins and antioxidants, the lung lining fluid is the first defense mechanism against ROS, protecting the underlying epithelium from oxidative damage. During specific oxidative stress conditions such as acute lung injury (ALI) from blunt force trauma, the antioxidant defense system of the lung can be

compromised. Supplemental oxygen therapy administered to ALI patients overwhelm the protective defense system, and inflammatory cells recruited to the site of damage release additional free radical species, altering permeability of the alveolar-capillary barrier. In many instances the build up of fluid in the alveolar spaces and impaired gas exchange can lead to diseases such as acute respiratory distress syndrome (ARDS).

During the acute phase of ARDS, there is an influx of protein rich fluid into the air spaces, recruitment of inflammatory cells (neutrophils, macrophages, lymphocytes), capillary injury and disruption of the alveolar epithelium (Ware 2000). Multiple predisposing disorders substantially increase risk of ARDS, including alcohol abuse and chronic lung disease. Overall, gram-negative sepsis is associated with the highest risk of progression to ARDS, over 40% (Ware 2000). Chronic unresolved lung damage leads to fibrosis, obstruction of the airway, and ultimately death.

Pathogenesis of ALI has been linked to oxidative stress due to excessive ROS load on the lung epithelium. Specific patient groups do not progress to full-blown ARDS following ALI, suggesting that development of this complex disorder may have a genetic component (Moss 1996; Moss 2000; Matthay 2003). Using positional cloning studies in inbred mice Cho *et al* (2002) identified *Nrf2* (NF-E2 related factor 2) as a candidate susceptibility gene for hyperoxia-induced lung inflammation and injury, a model of ARDS.

Comparison of the response of *nrf2*<sup>+/+</sup> and *nrf2*<sup>-/-</sup> mice exposed to hyperoxia further established *nrf2* as a candidate susceptibility gene. Relative to wildtype mice, *nrf2*<sup>-/-</sup> displayed increased lung inflammation, hyperpermeability and epithelial injury (Cho 2002). Expression of antioxidant enzymes (ie. GSTs, NQO1, HO1, GPx2) was significantly attenuated in *nrf2*<sup>-/-</sup> mice compared to *nrf2*<sup>+/+</sup> and confirmed a role for Nrf2-mediated antioxidant response element (ARE) induction during hyperoxic lung injury. Additional evidence for functional association of Nrf2 and antioxidant defense was provided by the observation that in lung tissue, Nrf2 was predominantly found in the epithelial cells lining the airways as well as alveolar macrophages where many ARE-bearing antioxidants reside (Cho 2002).

NRF2 is a cap'n'collar basic leucine zipper (CNC-bzip) transcription factor associated with Kelch-like ECH associating protein 1 (KEAP1) in the cytoplasm of unstressed cells. Oxidative stress disrupts sequestration of NRF2 by KEAP1, permitting

NRF2 phosphorylation by protein kinases and translocation to the nucleus. NRF2 then forms heterodimers with small Maf proteins that bind ARE-bearing detoxifying enzymes, inducing transactivation. Antioxidants such as NQO1, certain glutathione-S-transferases (GSTs), and  $\gamma$ -glutamate cysteine ligase regulatory (GCL $\gamma$ ) subunit, as well as classical antioxidant enzymes [e.g., NQO1, SOD, GPx], and HO1 contain AREs in their promoters (Table 1), and are upregulated by Nrf2 in oxidative stress studies in mice (Cho 2002). Transcriptional activation of ARE-bearing antioxidants by Nrf2 regulates response to oxidant-mediated injury.

### ***Oxidant-mediated injuries***

Rodent models of septic shock, BHT-toxicity and hyperoxic lung damage represent clinically relevant means to study acute lung injury (Chan 1999; Cho 2002; Victor 2003). Each of these insults produces enormous amounts of ROS that generate underlying tissue damage, and all three agents have been linked to Nrf2. The cytoprotective ability of Nrf2 to reduce acute pulmonary injury has been well established in animal models of hyperoxia, bleomycin and *tert*-butylated hydroxyquinone exposure (*t*BHQ) (Cho 2002; Nguyen 2004; Cho 2005). Similarly, in the absence of Nrf2, insufficient induction of cytoprotective antioxidants causes enhanced susceptibility to xenobiotics, environmental pollutants in diesel exhaust and food preservatives such as butylated hydroxytoluene (BHT) (Chan 1999; Aoki 2001; Hayes 2001; Li 2004).

Dietary phenolic compounds like BHT function as pro-oxidants and detoxifying enzyme inducers. Administration of BHT to mice caused transient lung damage and destruction of alveolar type I epithelial cells. Doses tolerated by wildtype mice caused ARDS in *nrf2*<sup>-/-</sup> mice after two days of treatment. Using a BHT-induced model of ALI, Chan *et al* (1999) observed that *nrf2*<sup>-/-</sup> mice were not only more susceptible to lung injury and inflammation, but also had reduced expression of pulmonary antioxidants including HO1, NQO1 and SOD1 both at baseline and following BHT treatment, compared to *nrf2*<sup>+/+</sup> mice. *Nrf2*<sup>-/-</sup> mice died of massive edema, hemorrhage and asphyxia caused by acute respiratory distress.

The surface glycolipid lipopolysaccharide (LPS) induces signal transduction pathways in viral and oxidative stress models (Victor 2003). Srisook *et al* (2005) observed increased nuclear translocation of Nrf2 and upregulation of HO1 in macrophages exposed to

LPS and BSO (DL-buthionine-[S,R]-sulfoximine). A similar increase in nuclear translocation and HO1 transactivation was observed by Rushworth *et al* (2005), using human monocytes exposed to LPS. LPS-induced HO1 expression required Nrf2 and PKC for activation. LPS activates gene transcription by binding cell surface receptors, inducing signal transduction pathways that lead to the phosphorylation of kinases including PKC, and activating transcription factors such as Nrf2 and NF- $\kappa$ B (nuclear factor kappa B).

### ***Identification of the antioxidant response element (ARE)***

The majority of ROS in phagocytic (ie. macrophages and neutrophils) and non-phagocytic cells are produced by the NAD(P)H oxidase complex or by oxidases of the cytochrome p450 and lipoxygenase systems. Superoxide and hydrogen peroxide mediate signal transduction via protein tyrosine phosphatases and receptor protein tyrosine kinases. Critical downstream components of redox-sensitive kinase cascades include the AP-1 (activating protein 1) and NF- $\kappa$ B family of transcription factors. AP-1 proteins (c-Fos, Fra, c-Jun) are basic leucine zipper (bZIP) transcription factors that bind TPA response elements (TRE) with the consensus sequence TGACTCA and are well established regulators of antioxidant enzymes such as GCL, SOD2 and HO1 (Lee 1996; Rahman 2000).

Simultaneously identified by Rushmore *et al* (1990) and Friling *et al* (1991) in two GST genes (GST-A2 and GST Ya, respectively), the ARE 5'-gTGACnnnGC-3' (Table 1) resembles the TRE sequence, and AP-1 proteins were originally predicted as primary transcription factor binding partners. Although some ARE activity is AP-1-mediated, the majority of ARE-bearing enzymes are activated by members of the Nrf transcription factor family.

Nrf1 and Nrf2 are expressed in a variety of tissues with Nrf2 expression abundant in the kidney, intestine and lung, where routine detoxification reactions occur (Itoh 1997). While Nrf1 is essential for development and cell survival through maintenance of redox balance, embryonic lethality of *nrf1*<sup>-/-</sup> mice precluded further study. Functional analyses of *nrf2*<sup>-/-</sup> mice identified Nrf2 as a critical regulator of ARE-mediated antioxidant response (Cho 2002). *In vitro* analysis with potent Nrf2 inducers (*t*BHQ, oltipraz, sulforaphane) have identified functional AREs in many antioxidant genes including GSTs, NQO1, HO1, GCLs, and SODs (Fahey 1999; Talalay 2001).

The ARE consensus sequence also resembles the Maf recognition element, or MARE [5'-tgcTGA(G/C)tcaGCA-3'; Table 1]. GC residues of the ARE and MARE are critical binding elements for gene induction in response to oxidative stimuli. Because they contain only DNA binding and dimerization motifs, small Maf proteins act through other elements such as Nrf2 to mediate the stress response. CNC proteins dimerize with small Maf proteins as obligate partners in promoting site specific ARE/MARE association (Nguyen 2000).

### ***NRF2 activation and regulation***

Nrf2 is a modular protein with distinct transactivation and DNA binding domains that affect its transcriptional activity (Figure 1). The Neh4 and Neh5 domains interact with the basal transcriptional machinery for optimal transactivation. Neh4 and Neh5 can bind the co-activator CBP independently and simultaneous binding by both domains synergistically activates Nrf2 target gene expression. The Neh 6 domain is considered a redox-insensitive degron that contributes to protein turnover in the nucleus during oxidative stress. The N-terminal Neh2 domain serves as the interaction domain with Keap1 to retain Nrf2 in the cytoplasm under homeostasis, while the C-terminal Neh3 domain contains the nuclear localization signal (NLS) required to recruit it to the nucleus during oxidative stress. Also located near the C-terminus, the CNC and bZIP domains are critical for dimerization with small Maf proteins and binding to the ARE.

Recent identification of a promoter mutation resulting in lower *Nrf2* mRNA levels and causing differential response to hyperoxia in mice suggests that transcriptional response may aid in regulation. Kwak *et al* (2002) have shown that Nrf2 binds to the ARE-like element located at -754 of the mouse *Nrf2* promoter and upregulates its own transcription in mouse keratinocyte PE cells. Chromatin immunoprecipitation assays indicate direct binding of Nrf2 to its own promoter, leading to persistent nuclear localization of Nrf2 and induction of antioxidants. This mechanism is supported by the observed transcriptional modulation present in several Nrf2 models (Kwak 2002; Cho 2005).

Although exposure to oxidants causes transient low-level changes in *Nrf2* transcription, recent studies have found the majority of regulation is posttranslational. Treatment with the oxidant tBHQ induced an overall increase in cellular Nrf2 without affecting its apparent rate of transcription (Nguyen 2004). Posttranscriptional response was also observed in cells treated with cadmium, sulforaphane, and DEM, all potent ARE

inducers. *Nrf2* transcript levels were found to remain steady and unaffected by other inducers or ARE-dependent genes in additional oxidative stress models (Nguyen 2000).

NRF2 is degraded by two mechanisms; KEAP1-mediated proteasomal degradation during homeostasis and KEAP1-independent NRF2 degradation in the nucleus under conditions of oxidative stress (Figure 2). KEAP1-dependent degradation requires interaction with the Neh2 domain of NRF2. Recent work by Katoh *et al* (2005) has shown key leucine residues clustered on an alpha helix close to the DIDLID element within the NRF2 Neh2 NTD are essential for KEAP1-mediated ubiquitin targeting in the cytosol. Mutations to these residues markedly decreased binding affinity of NRF2 to the Kelch domain of KEAP1. KEAP1-independent degradation is activated through the NRF2 Neh6 domain which regulates protein turnover in the nucleus during oxidative stress (Katoh 2005). Neh6-mediated degradation functions only in the nucleus, because the ubiquitin ligase is restricted to this compartment.

Activation of NRF2 involves mechanisms that interfere with the KEAP1-NRF2 complex, and could include posttranslational modifications affecting transactivation, binding affinity between the Kelch and Neh2 domains, or interactions with other key transcription factors and/or the basal transcription apparatus. Stability of intracellular proteins is often determined by their rate of proteasomal degradation by ubiquitination, and may regulate NRF2 stability and transcriptional activity. NRF2 has a high turnover rate of around 10 to 30 minutes (Nguyen 2004). Steady-state levels are maintained by constant rates of synthesis and degradation.

Protein modification by phosphorylation at Ser40 is believed to play a key role in regulating NRF2 stability. Mechanisms that decrease proteasomal degradation of NRF2 are sufficient to trigger its nuclear accumulation. ARE inducers are likely to act as distinct pathways to stabilize NRF2, not as proteasomal inhibitors. Accumulating evidence indicates that NRF2 protein accumulation constitutes a major regulatory mechanism mediating the activation of many ARE-dependent genes (Nguyen 2004).

Oxidative stress conditions stabilize NRF2 allowing translocation to the nucleus. NRF2 then forms heterodimers with other bZIP transcription factors for targeted ARE binding and antioxidant activation. Heterodimerization with small Maf proteins has positive and negative regulatory effects on ARE-bearing antioxidant enzymes based on cell

type, target gene or stimulus. CREB binding protein (CBP)/p300 and ARE-binding protein-1 interact with the Nrf2-Maf complex as co-activators in regulating ARE-mediated gene expression. Strong activation potential is conferred by the synergistic interaction between CBP and two transactivation domains of Nrf2 (Kato 2001). Cellular response to oxidative stress involves a rapid increase in Nrf2 in the nucleus, which leads to enhanced recruitment of Nrf2-Maf heterodimers to the promoters of ARE-bearing genes.

### ***ARE-bearing genes***

Upregulation of endogenous antioxidant defense systems maintain cellular redox homeostasis. Of the many antioxidants activated in response to oxidative stress, a large number contain Nrf2-Maf targeted AREs in their promoters. Classical antioxidants such as CAT and GPx directly neutralize and inactivate ROS-mediated reactions. GPx uses glutathione produced by GSR in maintaining redox balance. Glutathione synthesis, utilization and export are tightly regulated in order to maintain cellular functions such as apoptosis, metabolism, growth and transcription.

Antioxidants facilitate the conversion of reactive oxidized metabolites (quinones, peroxides, aldehydes) to reduced species through conjugation/reduction reactions. NQO1 converts damaging semiquinones and hydroquinones to less reactive by-products through two-electron reduction, protecting cellular membranes from lipid peroxidation. Induction of NQO1 occurs via the XRE (xenobiotic response element) or the ARE to protect against the cytotoxicity of numerous compounds such as benzene and tBHQ. The human NQO1 gene contains a core sequence TGACTCA that conforms perfectly to the consensus ARE (Table 1), and its expression is induced in response to oxidative stress.

Stress responsive proteins such as HO1 also protect against oxidative insult and contribute to redox balance. HO1 catalyzes the oxidative degradation of heme, liberating biliverdin, CO and ferrous iron as antioxidant by-products. Although heme is the conventional HO1 inducer, HO1 expression is markedly induced by hyperoxia and endotoxin in multiple cell types with profound cytoprotective effects (Otterbein 1999; Mantell 2000; Li 2004). A central feature of these inducers is the generation of ROS and accumulating evidence points to a role for HO1 in oxidant induced cellular injury. HO1 contains several enhancer elements that function as AREs (Table 1).

GPx2 reduces fatty acid hydroperoxides in the intestine and was recently found to be responsive to oxidative stress (Banning 2005). Oxidative stress mimics protein thiol oxidation and GPx2 is induced to counteract the damaging effects of these byproducts. GPx2 is induced in mouse models of hyperoxia and bleomycin-induced pulmonary fibrosis (Cho 2004; Cho 2005). Induction was completely lacking in *nrf2*<sup>-/-</sup> mice, suggesting an important role for this antioxidant in the Nrf2-mediated response to oxidants. Two putative AREs were identified in the human *GPx2* promoter, one containing a single basepair mismatch (TGAGG), and recent work by Banning *et al* (2005) has shown that only the intact ARE (TGAC) is transcriptionally active (Table 1).

### ***Objectives of Work***

Oxidative stress disrupts the NRF2-KEAP1 complex and KEAP1-mediated proteasomal degradation, leading to NRF2 stabilization and accumulation in the nucleus. Through co-activators such as CBP and small Maf proteins, NRF2 transactivates ARE-bearing antioxidant genes that help maintain redox homeostasis. Recent work indicates that posttranslational modifications regulate NRF2-mediated redox balance, most likely through phosphorylation by PKC. The effects of lowered levels of *NRF2* transcript have been largely ignored due to recent data showing minimal induction of *Nrf2* mRNA following oxidant exposure.

However, recent identification of a promoter mutation resulting in lower *Nrf2* mRNA levels and causing differential response to hyperoxia in mice suggests that transcriptional response may aid in regulation. Similarly, Kwak *et al* (2002) have shown that Nrf2 binds to the ARE-like element located at -754 of the mouse *Nrf2* promoter and upregulates its own transcription. Whether human NRF2 is regulated in an analogous fashion is unclear.

We hypothesized that based on work showing NRF2-mediated differential responsiveness in mice, mutations in the human *NRF2* promoter may confer differential response to oxidative injury. The emphasis of this thesis was to 1) identify and characterize variations in the *NRF2* promoter that affect its function; 2) assess transcriptional effects of promoter variants on antioxidant gene expression; and 3) determine whether promoter variants affect translational activation of antioxidant enzymes.

**Table 1. Consensus sequences for antioxidant response elements and bZIP transcription factors involved in oxidative stress.** Capitalized bases are conserved, those shown with parentheses and a slash can vary between two bases. Bases designated “n” can be any base, and underlined bases indicate deviation from the canonical ARE consensus sequence. \* See chapter 1 (Figure 1) for details on the consensus sequence for *NRF2*.

<b>Gene/element</b>	<b>Consensus Sequence</b>				
<b>ARE</b>	(a/g)	<b>TGAC</b>	<b>nnn</b>	<b>GC</b>	<b>nnn</b>
<i>NQO1</i>	<b>g</b>	<b>TGAC</b>	<b>tca</b>	<b>GC</b>	<b>aga</b>
<i>H01</i>	<b>c</b>	<b>TG<u>C</u>C</b>	<b>tca</b>	<b>GC</b>	<b>a</b>
	<b>g</b>	<b>TGAC</b>	<b>tca</b>	<b>GC</b>	<b>a</b>
<i>GPx2</i>	<b>g</b>	<b>TGAC</b>	<b>tag</b>	<b>GC</b>	
		<b>TGAG<u>G</u></b>	<b>nnn</b>	<b>GC</b>	
<i>GSR</i>	<b>c</b>	<b>TGAC</b>	<b>gag</b>	<b>GC</b>	
<i>NRF2*</i>		<b>TG<u>C</u>C</b>	<b>gg(c/a)</b>	<b>GC</b>	
<b>MARE</b>	<b>tgc</b>	<b>TGA(G/C)</b>	<b>TCA</b>	<b>GC</b>	<b>a</b>

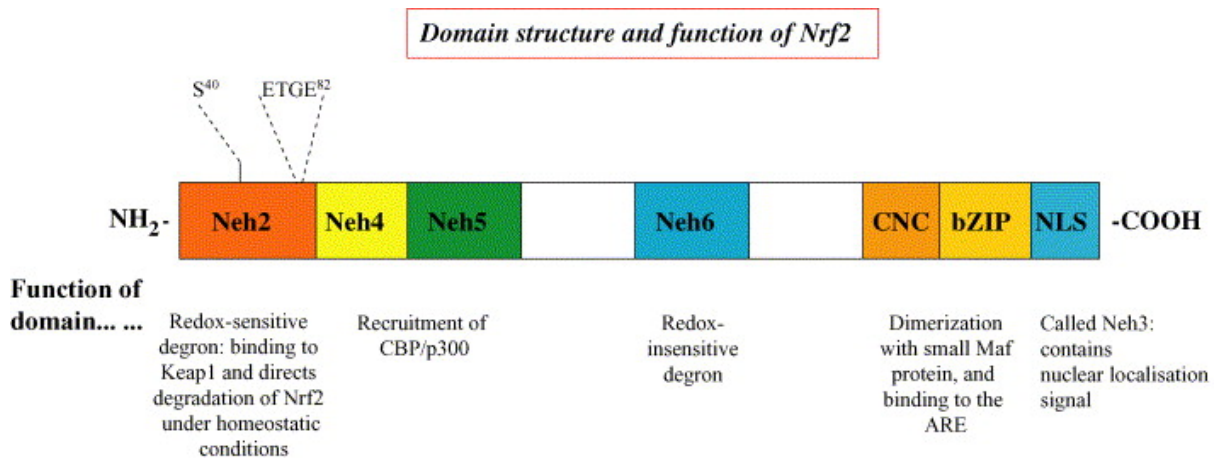

**Figure 1. Domain structure and function of *Nrf2*.** Adapted from Nioi P. and Hayes J.D. (2004) Mutation Research **555** (1-2):149-171.

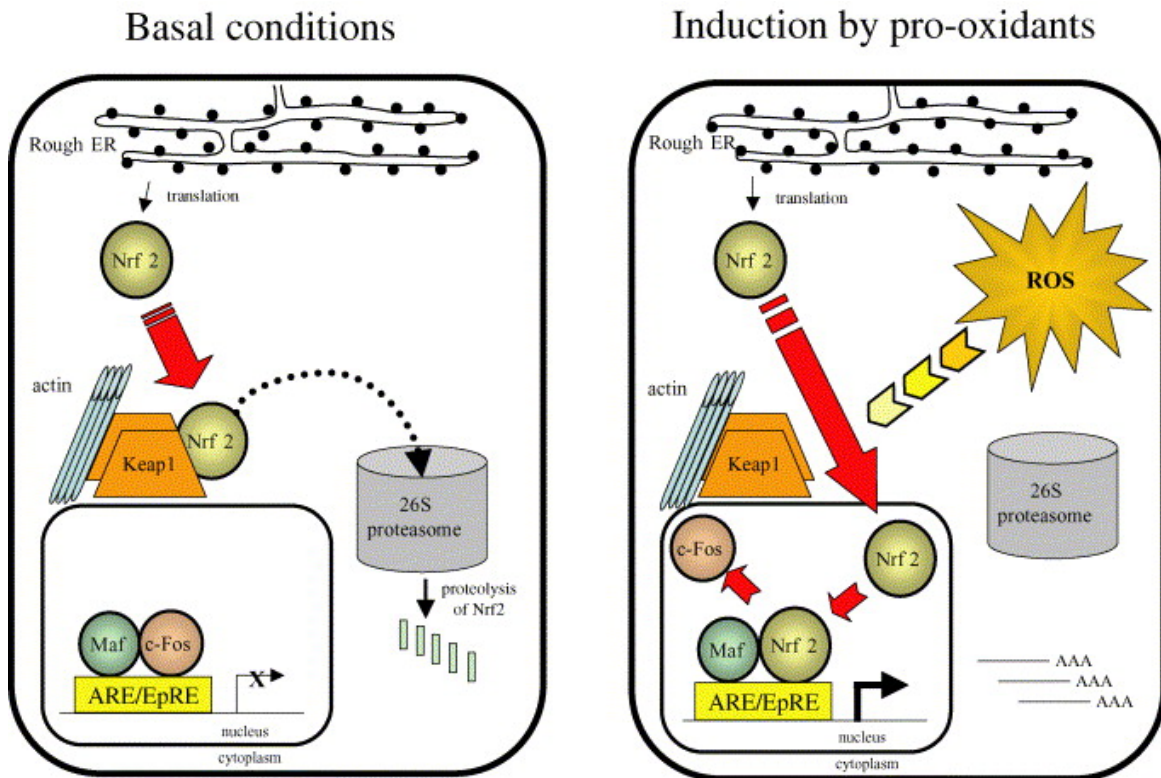

**Figure 2. Transcription factors recruited to the ARE under homeostasis or during oxidative stress conditions.** Adapted from Nioi P. and Hayes J.D. (2004) *Mutation Research* **555** (1-2):149-171.

## References

- Aoki, Y., Sato, H., Nishimura, N., Takahashi, S., Itoh, K., Yamamoto, M. (2001). "Accelerated DNA adduct formation in the lung of the Nrf2 knockout mouse exposed to diesel exhaust." Toxicology and Applied Pharmacology **173**(3): 154-160.
- Banning, A., Deubel, S., Kluth, D., Zhou, Z., Brigelius-Flohe, R. (2005). "The GI-GPx gene is a target for Nrf2." Molecular and Cellular Biology **25**(12): 4914-4923.
- Chan, K., Kan, Y.W. (1999). "Nrf2 is essential for protection against acute pulmonary injury in mice." Proceedings of the National Academy of Sciences U SA **96**(22): 12731-12736.
- Cho, H.-Y., Jedlicka, A.E., Reddy, S.P., Zhang, L.Y., Kensler, T.W., Kleeberger, S.R. (2002). "Linkage analysis of susceptibility to hyperoxia. Nrf2 is a candidate gene." American Journal of Respiratory Cell and Molecular Biology **26**(1): 42-51.
- Cho, H.-Y., Reddy, S.P., Debiase, A., Yamamoto, M., Kleeberger, S.R. (2005). "Gene expression profiling of NRF2-mediated protection against oxidative injury." Free Radical Biology and Medicine **38**(3): 325-343.
- Cho, H.-Y., Reddy, S.P., Yamamoto, M., Kleeberger, S.R. (2004). "The transcription factor NRF2 protects against pulmonary fibrosis." FASEB Journal **18**(11): 1258-1260.
- Cho, H., Jedlicka, A.E., Reddy, S.P., Kensler, T.W., Yamamoto, M., Zhang, L.Y., Kleeberger, S.R. (2002). "Role of NRF2 in protection against hyperoxic lung injury in mice." American Journal of Respiratory Cell and Molecular Biology **26**(2): 175-182.
- Fahey, J. W., Talalay, P. (1999). "Antioxidant functions of sulforaphane: a potent inducer of phase II detoxification enzymes." Food and Chemical Toxicology **37**(9-10): 973-979.
- Hayes, J. D., McMahon, M. (2001). "Molecular basis for the contribution of the antioxidant response element to cancer chemoprevention." Cancer Letters **174**(2): 103-113.
- Itoh, K., Chiba, T., Takahashi, S., Ishii, T., Igarashi, K., Katoh, Y., Oyake, T., Hayashi, N., Satoh, K., Hatayama, I., Yamamoto, M., Nabeshima, Y. (1997). "An Nrf2/small Maf heterodimer mediates the induction of phase II detoxifying enzyme genes through antioxidant response elements." Biochemical and Biophysical Research Communications **236**(2): 313-322.
- Katoh, Y., Iida, K., Kang, M.I., Kobayashi, A., Mizukami, M., Tong, K.I., McMahon, M., Hayes, J.D., Itoh, K., Yamamoto, M. (2005). "Evolutionary conserved N-terminal domain of Nrf2 is essential for Keap1-mediated degradation of the protein by the proteasome." Archives of Biochemistry and Biophysics **433**(2): 342-350.
- Katoh, Y., Itoh, K., Yoshida, E., Miyagishi, M., Fukamizu, A., Yamamoto, M. (2001). "Two domains of Nrf2 cooperatively bind CBP, a CREB binding protein, and synergistically activate transcription." Genes Cells **6**(10): 857-868.

Kwak, M. K., Itoh, K., Yamamoto, M., Kensler, T.W. (2002). "Enhanced expression of the transcription factor Nrf2 by cancer chemopreventive agents: role of the antioxidant response element-like sequence in the nrf2 promoter." Molecular and Cellular Biology **22**(9): 2883-2892.

Lee, P. J., Alam, J., Sylvester, S.L., Inamdar, N., Otterbein, L., Choi, A.M. (1996). "Regulation of heme oxygenase-1 expression in vivo and in vitro in hyperoxic lung injury." American Journal of Respiratory and Cell Molecular Biology **14**(6): 556-568.

Li, N., Alam, J., Venkatesan, M.I., Eiguren-Fernandez, A., Schmitz, D., DiStefano, E., Slaughter, N., Killeen, E., Wang, X, Huang A., Wang, M., Miguel, A.H., Cho, A., Sioutas, C., Nel, A.E. (2004). "Nrf2 is a key transcription factor that regulates antioxidant defense in macrophages and epithelial cells: protecting against the proinflammatory and oxidizing effects of diesel exhaust chemicals." Journal of Immunology **173**(5): 3467-3481.

Mantell, L. L., Lee, P.J. (2000). "Signal transduction pathways in hyperoxia-induced lung cell death." Molecular Genetics and Metabolism **71**(1-2): 359-370.

Matthay, M., Zimmerman, G.A., Esmon, C., Bhattacharya, J., Collier, B., Doerschuk, C.M., Floros, J., Gimbrone, M.A. Jr, Hoffman, E., Hubmayr, R.D., Leppert, M., Matalon, S., Munford, R., Parsons, P., Slutsky, A.S., Tracey, K.J., Ward, P., Gail, D.B., Harabin, A.L. (2003). "Future directions in acute lung injury: summary of a National Heart, Lung and Blood Institute working group." American Journal of Respiratory and Critical Care Medicine **167**(7): 1027-1035.

Moss, M., Bucher, B., Moore, F.A., Moore, E.E., Parsons, P.E. (1996). "The role of chronic alcohol abuse in the development of acute respiratory distress syndrome in adults." Journal of the American Medical Association **275**(1): 50-54.

Moss, M., Guidot, D.M., Steinberg, K.P., Duhon, G.F., Treece, P., Wolken, R., Hudson, L.D., Parsons, PE (2000). "Diabetic patients have a decreased incidence of acute respiratory distress syndrome." Critical Care Medicine **28**(7): 2187-2192.

Nguyen, T., Huang, H.C., Pickett, C.B. (2000). "Transcriptional regulation of the antioxidant response element. Activation by Nrf2 and repression by MafK." Journal of Biological Chemistry **275**(20): 15466-15473.

Nguyen, T., Yang, C.S., Pickett, C.B. (2004). "The pathways and molecular mechanisms regulating Nrf2 activation in response to chemical stress." Free Radical Biology and Medicine **37**(4): 433-441.

Otterbein, L. E., Mantell, L.L., Choi, A.M. (1999). "Carbon monoxide provides protection against hyperoxic lung injury." American Journal of Physiology **276**(4 Pt 1): L688-L694.

Rahman, I., MacNee, W. (2000). "Oxidative stress and regulation of glutathione in lung inflammation." European Respiratory Journal **16**: 534-554.

Talalay, P., Fahey, J.W. (2001). "Phytochemicals from cruciferous plants protect against cancer by modulating carcinogen metabolism." Journal of Nutrition **131**(11 Supplement): 3027S-3033S.

Ware, L.B., Matthay, M.A. (2000). "The acute respiratory distress syndrome." New England Journal of Medicine **342**: 1334-1349.

Victor, V. M., De la Fuente, M. (2003). "Several functions of immune cells in mice changed by oxidative stress caused by endotoxin." Physiological Research **52**(6): 789-796.

**Chapter 1**  
**Identification of ARE variant and functional studies**

**Rationale:** NRF2 is a transcription factor involved in the response to hyperoxia in mice and may play a role in oxidative lung disease. We sequenced the promoter region of human *NRF2* to identify functionally relevant single nucleotide polymorphisms (SNPs). **Methods:** 1 kb of the promoter was sequenced, and ten individuals from four ethnic populations were screened for SNPs. Two *NRF2* promoter constructs [727-Luc (intact promoter) and 538-Luc (truncated promoter, with polymorphic sites deleted)] and polymorphic variants of the 727-Luc promoter were amplified from genomic DNA, gel purified and cloned into pGL3 vector upstream of the reporter gene, luciferase. Promoter reporter constructs were transfected into pulmonary epithelial cells (A549) and luciferase expression was analyzed with or without oxidant stimulation. To analyze specific binding at the polymorphic site, nuclear proteins (5 mg) were pre-incubated with anti-NRF2 antisera (2 ml) or rabbit IgG (2 ml), and then processed for EMSA using wildtype and variant [ $\gamma^{32}\text{P}$ ]-ATP labeled oligonucleotides. **Results:** Three promoter SNPs (-653, -651, and -617) were identified in *NRF2* at relatively high frequency (5-60%). Intact 727-Luc reporter had 4-fold higher luciferase expression, compared to the truncated 538-Luc reporter without the SNPs. In comparison to the wildtype 727-Luc construct, -651 and -617 variants had significantly diminished basal level activity (over 50%). However, promoter polymorphisms did not significantly affect inducible activity. Results from EMSA show significantly decreased DNA:protein and DNA:NRF2 antibody complex binding in the presence of the -617 A variant allele. **Conclusions:** The DNA sequence between -538 and -727 most likely regulates basal *NRF2* promoter activity. Promoter SNPs -617 (C/A) and -651 (G/A) diminish basal levels of *NRF2* transcription but did not significantly decrease promoter activity in response to oxidant stimulation. Because NRF2 up-regulates genes involved in cellular defense and detoxification, decreased basal levels could have significant effects on downstream genes involved in oxidative stress.

## Introduction

The coordinated induction of ARE-dependent genes in response to oxidative stress increases the capacity of cells to detoxify reactive chemicals, minimize DNA damage and restore redox homeostasis. Central to homeostatic balance is the core ARE sequence 5'-TGACnnnGC-3' which determines basal and inducible activity. Several factors including the ARE sequence context, nature of the chemical inducer, and cell type determine activity of a particular ARE-bearing gene (Nguyen 2000). The presence of a GC box at the 3' end of the ARE resembles the Maf recognition element (MARE) and is critical for Maf recruitment and binding. This feature is unique to the ARE and distinguishes it from the TPA response element (TRE, 5'-TGACTCA-3') such that AP1 proteins do not bind the ARE with high affinity. In many genes the ARE has an embedded TRE sequence, raising the possibility that these genes are under dual transcriptional control.

Small Maf are essential cofactors of transcriptional regulation mediated through cis-acting elements. Initial studies by Itoh *et al* (1997) have shown that NRF2 requires Maf as an obligate binding partner for ARE interaction in order to transactivate downstream gene targets. EMSA analysis indicated strong binding affinity of a purified Nrf2:MafK complex to the mouse GSTY1 promoter ARE sequence. Neither protein could bind to the ARE sequence in the absence of the other, and a 400-fold excess of cold oligonucleotide was required to compete off the bound protein, suggesting high binding specificity. By themselves, small Maf proteins contain only dimerization and DNA binding motifs, and lack transactivation domains.

Using fibroblasts lacking all three small Maf proteins (Maf F, K and G), Katsuoka *et al* (2005) showed a complete loss of induction in almost all Nrf2-dependent genes. Each small Maf alone was capable of supporting Nrf2-mediated transcriptional activation, providing redundancy should one Maf protein be inactivated. Additional bZIP transcription factors such as AP1 may bind to the MARE to affect transcriptional activity. MafK can dimerize with c-Fos forming a high-affinity DNA binding complex to transcriptionally repress Nrf2-mediated gene expression (Nguyen 2004). Overexpression of Fos family proteins inhibited ARE activity, suggesting that AP1 complexes may negatively regulate ARE-bearing antioxidants (Nguyen 2004). Binding to the embedded AP1 site may preclude access of ARE binding factors and coactivators of transcription such as CBP/p300.

In addition to the principal role of the Nrf2:Maf heterodimer in ARE activation, recent studies have shown that higher order transcriptional coactivators are also involved in ARE regulation. Microinjection studies by Zhu *et al* (2001) indicate a hierarchy of transcriptional regulation, beginning with direct ARE-specific interaction between the Nrf2:Maf complex and the consensus sequence, followed by interactions with secondary and tertiary co-activators. GFP expression was significantly diminished by microinjected antibodies individually directed against Nrf2, MafK, p300 and CBP, suggesting the involvement of all four factors in transcriptional regulation of the ARE. Proposed secondary coactivators include ARE-binding protein-1 (ARE-BP-1), an ARE specific p160 family member known to interact with CBP/p300. CBP and p300 proteins are essential tertiary coactivators for efficient gene induction in studies of transcription factors including NF- $\kappa$ B, AP-1, and nuclear receptors (Kwok 1994; Kamei 1996; Zhang 1996; Gerristen 1997; Grossman 2001; Lee 2001). CBP/p300 proteins nucleate around the transcription factor complex, remodeling chromatin to an open conformation and directly interact with the basal transcription apparatus to augment transactivation of gene targets.

Recent *in vitro* DNA binding assays have shown that Nrf2 is a critical stimulator of ARE-driven transcription (Nguyen 2004). Positional cloning studies in mice identified Nrf2 as a key regulator of a host of ARE-bearing antioxidant enzymes upregulated in response to hyperoxia. Subsequent studies demonstrated Nrf2 induction in response to tBHQ, sulforaphane, etc, with resulting activation of ARE-inducible enzymes. Studies of *nrf2*<sup>-/-</sup> mice showed increased inflammation and lung injury with decreased antioxidant expression and have clearly established its role in activating antioxidant response pathways critical for cellular defense against oxidative stress (Cho 2002; Cho 2005). Nrf2 appears to be an essential regulatory element in response to oxidant injury.

Nrf2 autoregulates transcription through ARE-like sequences located in the proximal promoter (Kwak 2002). Of the two ARE-like elements present, AREL1 is a perfect match to the ARE, and AREL2 contains one additional base before the GC box (-754; TGACTgtGGC). Mutation of the core TGAC sequence of either AREL1 or AREL2 in the full-length promoter abolished activation in response to the phenolic antioxidant D3T (3H-1,2-dithiole-3-thione) in mouse keratinocyte PE cells (Kwak 2002). Furthermore, chromatin immunoprecipitation (ChIP) assays demonstrated that Nrf2 associated with a region adjacent to or including the

AREL2 sequence in its own promoter (Kwak 2002). Enhancer analysis with reporter constructs indicated that AREL2 alone can activate low-level Nrf2 expression compared to vehicle control; however, both elements were required to fully activate Nrf2 by D3T. Intact promoter activity was increased two-fold after treatment with D3T and Nrf2 accumulated in the nucleus within 20 minutes. *Nrf2* mRNA levels increased approximately 2 fold within 6 hours of treatment and returned to basal levels by 24 hours. Overexpression of Nrf2 doubled the activity of reporter constructs and coexpression with MafK further enhanced activation. These results suggest that autoregulation of Nrf2 expression can lead to sustained signaling of antioxidant gene expression.

NRF2 binds to the antioxidant response element ARE and upregulates detoxifying enzymes in response to oxidative stress. Recently, susceptibility to oxidant-induced acute lung injury (ALI) was mapped to a region on chromosome 2 containing *Nrf2* in a murine model. These observations prompted investigation of *NRF2* as a candidate susceptibility gene for ALI in humans. Functional SNPs were identified in the mouse *Nrf2* promoter, and by homology may also be present in human *NRF2*. Kwak *et al* (2002) have recently shown that Nrf2 binds to the ARE-like element located at -754 of the mouse *Nrf2* promoter and autoregulated transcription in mouse keratinocyte PE cells. Whether human NRF2 is regulated in an analogous fashion is unclear. The present study was designed to identify single nucleotide polymorphisms (SNPs) in the human *NRF2* promoter and to determine the influence of *NRF2* SNPs on gene regulation and DNA binding.

## **Materials and Methods**

### ***Sequencing analysis***

Forty commercially available DNA samples were screened (Coriell Institute, Camden, NJ) for SNPs in the promoter region of *NRF2*. In addition, as these 40 samples included 10 subjects each from different ethnic backgrounds (10 each of European, African, and Asian descent), we had a detection rate of 90% for SNPs present in as little as 10% of each ethnic background (Mander 2000). Primers were designed (Sigma Genosys, The Woodlands TX) to span 1 kb of the *NRF2* promoter in overlapping segments (Table 2). 100 ng of genomic DNA was amplified using the Epicentre Failsafe system (Madison WI), products purified using the GenElute PCR cleanup kit (Sigma, St. Louis MO) and sequencing

reactions performed with dGTP dye terminator kits (Applied Biosystems, Foster City CA). Purified products were analyzed on an ABI 377 Automated DNA Sequencer (Applied Biosystems, Foster City CA). Sequence results were aligned and verified by overlapping reads using additional internal primers (Sigma Genosys, The Woodlands TX).

### ***Reporter Gene Assays***

Reporter gene assays are often used to determine effects of promoter mutations on transcriptional activity. The pGL3 basic reporter vector contains a genetically engineered luciferase gene lacking a promoter. When adjacent promoter regions are cloned into the pGL3 vector, there is strong transcriptional activation. Mutations such as insertions, deletions, or SNPs in the promoter of the target gene can influence transcriptional activity of the luciferase reporter gene which is fluorometrically detected versus an internal control.

To determine whether promoter polymorphisms influence transcript levels, the -727 to +131 region of *NRF2* containing the SNP was cloned upstream of the luciferase reporter gene, and its expression analyzed by transient transfection using reporter assays. The role of the -727 to -538 promoter region, which contains all three SNPs, was investigated by generating two constructs [-727 to +131 bp, (727-Luc) and -538 to +131bp (538-Luc, lacking the SNPs)] and comparing their promoter activity. In order to examine the effects of the individual SNP on transcriptional activity, we also amplified the 5'-flanking region of genomic *NRF2* to generate polymorphic variants of the 727-Luc sequence (-617 A, -651A, -653G/-651A). Constructs were verified by sequencing, and transiently transfected into A549 cells [The American Type Culture Collection (ATCC), Manassas VA].

Cells were plated in 12-well plates at 70% confluency 24 hours prior to transfection. The following day, cells were transfected with 0.5 µg of NRF2-ARE luciferase plasmids or empty pGL3 control vector. The pRL-TK plasmid encoding Renilla luciferase was included as an internal control of transfection efficiency. Transient transfection experiments were performed using the Qiagen Effectene transfection kit (Qiagen, Valencia CA). Briefly, 2.4 µl of Enhancer was dissolved in 70 µl buffer EC, and the DNA-enhancer mixture incubated at room temperature for 5 minutes. Following incubation, 6 µl Effectene reagent was added, and the mixture was incubated an additional 10 minutes at room temperature to allow transfection-complex formation. Media (800 µl) was added and the resulting mixture immediately transferred to wells containing the A549 cells in 400 µl of fresh media. Cells

were harvested 24 hours after transfection and the luciferase assay was performed using the Dual-Luciferase Reporter Assay system (Promega, Madison WI). Luciferase activity was assessed in three independent samples and all experiments were repeated in triplicate.

### ***Electrophoretic Mobility Shift Assay (EMSA)***

Electrophoretic mobility shift assays are used to assess binding of transcription factors to regulatory sequences on the DNA. Short double stranded DNA fragments that encompass the target transcription factor region are end-labeled with  $^{32}\text{P}$  radionucleotides and then incubated with nuclear extracts in a binding buffer. In a parallel experiment, the transcription factor-nuclear extract complex can also be incubated with antibody to detect a supershift of additional proteins that bind transcription factors in specific regulatory regions.

An aliquot (5  $\mu\text{g}$ ) of human lung nuclear protein (Active Motif, Carlsbad CA) was incubated on ice with binding buffer for 15 minutes, followed by addition of  $3 \times 10^4$  cpm [ $\gamma^{32}\text{P}$ ]ATP (Amersham Biosciences, Piscataway NJ) end-labeled wildtype or variant probes (Table 2) and incubated for 30 minutes at room temperature. The binding of transcription factors to their cognate sites is also influenced by the presence of flanking DNA sequences. Thus, to assess the influence of flanking MZF1 and AP-1 sites on NRF2 binding, EMSA assays were performed using a fragment containing all three sites.

The binding affinity of this fragment was compared to that of a shorter fragment, which contains only the NRF2 binding site. A higher degree of specificity is conferred with shorter oligonucleotide fragments, since there is a lower likelihood of non-specific hybridization. Short (26 base pairs) and long (62 base pairs) fragment sequences were used for the EMSA experiments; the short fragment overlaps only the consensus sequence for NRF2, whereas the long fragment overlaps potential binding sites for AP-1, MZF1 (Myeloid zinc finger 1) and NRF2 (ARE) (T Heinemeyer 1998).

To analyze specific binding of NRF2 at the -617 polymorphic site, nuclear proteins (5  $\mu\text{g}$ ) were pre-incubated with polyclonal rabbit anti-NRF2 antiserum (2  $\mu\text{l}$ ) or control IgG (2  $\mu\text{l}$ ), and processed for EMSA as described above. To verify that the -617 site was not bound by AP1, specific binding of AP1 family members was assessed as above, using rabbit polyclonal anti-cFos antiserum or anti-cJun antiserum (2  $\mu\text{l}$ ). Samples were electrophoresed and autoradiographed with an intensifying screen at  $-70^\circ\text{C}$ .

### ***Statistical analysis***

Data were tested for differences between groups by one-way analysis of variance (ANOVA) with Student-Newman-Keuls (SNK) *a posteriori* comparisons of means (Sigma Stat, Jandel Scientific Software, San Rafael CA). A two-sided p-value of less than 0.05 was considered statistically significant.

## **Results and Discussion**

### ***SNP discovery***

We identified three *NRF2* promoter polymorphisms at positions -617 (C/A), -651 (G/A) and -653 (A/G) (Figure 2). Yamamoto *et al* (2004) concurrently identified and validated the same three promoter mutations using RNase protection assays. Our studies have focused primarily on the functional significance of these polymorphisms.

Polymorphism allelic frequencies for -617 and -653 were above 10% in the four ethnic groups (Table 3). Transcription factor motif analysis (Heinemeyer 1998) showed variations at -653/-651 and -617 alter the consensus recognition sequences for MZF-1 (Myeloid zinc finger-1) and NRF2, respectively (Figure 2A), suggesting that these polymorphisms may affect *NRF2* transcription. To examine this concept, we transiently transfected the 727-Luc (or -617C allele) and 538-Luc (which lack the polymorphisms) into A549 cells and assessed basal level activity of the *NRF2* promoter with or without polymorphisms. Compared to basic pGL3-vector alone, a higher level of activity was observed in the 538-Luc reporter. Relative to 538-Luc, the 727-Luc reporter had four-fold higher luciferase activity (Figure 3A) indicating that the -538 to -727 region most likely contains DNA sequences required for high level *NRF2* promoter activity.

### ***SNP function***

We cloned the 727 bp *NRF2* construct bearing the indicated polymorphisms upstream of the Luc gene to determine functional significance of *NRF2* promoter polymorphisms. Variants and putative transcription factor binding sites encompassed the SNP region (-659 to -608) (Figure 3B). Importantly the NRF2 binding site resembled an ARE sequence with one basepair mismatch (5'-TGCCnnnGC-3'). In transient transfection assays, luciferase activity was significantly (two-fold) higher in -617C wildtype compared to promoter constructs bearing -617A and -651A variants. Basal activity of cells transfected with a promoter

construct bearing -651A and -653G polymorphisms did not differ from that of cells transfected with -651A alone. Treatment of cells with oxidative stress agents (CdCl<sub>2</sub>, BHT, H<sub>2</sub>O<sub>2</sub>) did not significantly affect luciferase expression driven by wildtype and polymorphic constructs in A549 cells (data not shown). NRF2 is constitutively expressed in a majority of cell types, thus it is likely that promoter polymorphisms at positions -617 (C to A) or -651 (G to A) affect basal level expression of NRF2, thereby resulting in attenuation of ARE-mediated gene transcription.

Using gel shift analysis (EMSA) with antibodies specific to cFos and cJun we probed -617 radiolabeled short oligos to determine whether AP1 binds to the ARE site in the presence or absence of mutation. No supershift was observed for either AP1 family member to either the wildtype, heterozygote or mutant sequence, which suggests that the ARE site is specific for NRF2 binding. Although consensus sequences for the TRE and ARE have a high degree of similarity, the presence of the GC box at the 3' end enhances specificity for NRF2 and not AP1 binding. We also assessed binding affinity of the -651 site with or without mutation, and found substantially increased total binding with the A allele (data not shown). Because no MZF1 antibody was available at the time of the study, supershift analysis was not performed for the -651 site. Although diminished *NRF2* transcription was observed with the -651 mutation using luciferase assays, other putative cis-acting factors (such as MZF1) may bind tightly to the site. Effects of these transcription factors or additional co-activators are not known at this time. Since we did not see an overall negative effect in total binding at the -651 locus, we focused instead on the -617 site which contained the binding site for the ARE. Recent work by Kwak (2002) demonstrated autoregulation of Nrf2 by an ARE-like element in the *nrf2* promoter region. Similar results were seen in our luciferase data of the -617 SNP in the human *NRF2* gene, with the -617A allele showing reduced *NRF2* expression. Additionally, EMSA results showed a reduction in NRF2 binding with the -617A allele which suggests the -617 mutation may be the cause of diminished activity.

A multitude of transcription factors are autoregulated in a similar manner, by binding response elements in their promoter regions to control transcription. Regulation of NF- $\kappa$ B2 is mediated by posttranslational modifications, as well as through  $\kappa$ B elements in its promoter (Liptay 1994). Autoregulation permits positive regulation following cell stimulation and negative regulation at rest. Two putative  $\kappa$ B elements were identified in the

promoter and NF- $\kappa$ B2 preferentially binds the  $\kappa$ B<sub>1</sub> element as both a homodimer and heterodimer for transcriptional activation of its gene product (Liptay 1994). In the absence of NF- $\kappa$ B, a repressor or repressive complex binds the site overlapping the two  $\kappa$ B elements, inhibiting repressor binding and restoring basal levels of activity. Repressed basal NF- $\kappa$ B2 transcription in the inactivated state enables the cell to tightly control NF- $\kappa$ B2 activity. Autoregulatory mechanisms also exist for AP-1, NF- $\kappa$ B1, I $\kappa$ B $\alpha$  and c-Jun (Karin 2000; Okada 2003).

Early studies by Favreau *et al* (1995) using the rat Nqo1 ARE indicated point mutations to the core **TGAC** sequence abolished basal and inducible ARE activity. However, these functional studies only considered substitution of an A or a C residue for each of the three positions within the TGA sequence. Subsequent mutational analysis of the ARE consensus sequence suggest derivations from the core ARE sequence (5'-TGACnnnGC-3') are functionally active. Studies by Erickson *et al* (2002) have identified an ARE in the human GCLM (glutamate-cysteine ligase modifier subunit) gene that deviates from the canonical ARE sequence. The GCLM is a perfect ARE match except for a T residue at -330 (5'-TTACnnnGC-3' instead of 5'-TGACnnnGC-3'). Although the TTAC motif exhibited lower levels of constitutive expression (25% less) compared to the TGAC motif it was still capable of full induction following tBHQ stimulation (Erickson 2002).

Although we did not compare binding and activity in the presence of an intact TGAC sequence, our promoter ARE element with one basepair mismatch (TGC instead of TGA) was able to bind NRF2 with high affinity and specificity as shown in supershift analyses of the wildtype promoter sequence (5'-TGCCggcGC-3'). Despite early studies by Favreau *et al* (1995) indicating point mutations (C and A) to this sequence that showed abolished NRF2 binding, our EMSA results indicate strong binding to the TGC sequence for activation of NRF2. Similarly, another base in the TGA motif can be substituted as shown by Erickson *et al* (2002) in studies of the naturally occurring GCLM promoter ARE. In our study, instead of mutations to the core ARE sequence, mutations to the non-conserved region (indicated by nnn in the consensus sequence) diminished binding. Formation of protein-DNA complex was significantly decreased by the -617 polymorphism in the ARE sequence (Figure 3C) from TGCCggcGC to TGCCggaGC. Results from supershift assays with anti-NRF2 antiserum show strong binding of NRF2 to the wildtype ARE sequence and significantly

diminished binding to the mutated element, suggesting that NRF2 autoregulates transcription through this promoter region.

## Summary

We identified three promoter polymorphisms in *NRF2* with potential functional significance. Two of these promoter SNPs (-617 C/A and -651 A/G) were functionally significant based on diminished luciferase activity of promoter deletions and polymorphic constructs. Additionally, the -617 A substitution altered the consensus sequence for an ARE element, and binding affinity was decreased at this locus.

As our results have shown, conservation of the TGAC sequence was not required for strong *NRF2* transcriptional activity, suggesting a means for genetic diversity and autoregulation. Derivation in the non-conserved region of the NRF2 ARE produced lower levels of expression in -617A variants. While *NRF2* expression was present in wildtype and mutant promoter constructs during homeostasis, variant cells with aberrant NRF2 expression may be highly susceptible to oxidative stress. NRF2 is regulated primarily by KEAP1 inhibition and proteasomal degradation in the cytosol, and autoregulation can occur in the nucleus independent of these two modes of turnover. NRF2 also contains a redox-insensitive degron that provides yet another means of regulation in the nucleus. Constitutive activation of NRF2 in the nucleus would be particularly damaging to the cell as demonstrated in *keap1*<sup>-/-</sup> mice which develop hyperkeratosis due to continuous ARE activation (Wakabayashi 2003). Regulation of NRF2 by multiple pathways is critical for cell survival and mutation at the -617 ARE site provides an additional means to control expression.

A significant limitation of our study is the focus on promoter mutations, without consideration of coding sequence variations that may have greater functional impact on transcription. To address this limitation, we sequenced the coding region of *NRF2* in our ethnic cohort and did not find allelic variants at high enough frequency for inclusion in our functional study. However, there are also potential haplotype effects of *NRF2* coding SNPs or neighboring gene polymorphisms that could affect *NRF2* transcription. Additional transcription factors or higher order co-activators such as ARE-BP-1 may also impact transcription or interact with Maf proteins to repress transcription. These studies are meant to address only functional consequences of NRF2 ARE mutations, and DNA-*NRF2* binding

affinity at the ARE locus. Transcriptional regulation is highly complex, and these functional studies have only begun to address the many factors that contribute to transactivation.

**Table 2. NRF2 primers for promoter region polymorphisms, as well as electrophoretic mobility shift assay (EMSA) oligonucleotides.**

<b>Promoter Region</b>	<b>Primer</b>	<b>Amplified Size (bp)</b>	<b>Annealing Temp (°C)</b>
-1058 to -464	5'-AGC ATA CTT GGA AGT AAC AAG GAG A-3' 5'-CTT TTA TCT CAC TTT ACC GCC C-3'	593	57
-741 to -318	5'-GAC CAC TCT CCG ACC TAA AGG-3' 5'-CGA GAT AAA GAG TTG TTT GCG AA-3'	423	59
-383 to +116	5'-CCA ACT GTT TAA ACT GTT TCA AAG C-3' 5'-AGG CAG CTC CAA GTC CAT C-3'	498	58
<b>EMSA</b>	<b>Primer</b>	<b>Amplified Size (bp)</b>	<b>Annealing Temp (°C)</b>
-617F wt -617R wt	5'-CAC GAG CTG CCG GCG CTG TCC ACA TC-3' 5'-GAT GTG GAC AGC GCC GGC AGC TCG TG -3'	26	95
-617F var -617R var	5'-CAC GAG CTG CCG GAG CTG TCC ACA TC-3' 5'-GAT GTG GAC AGC TCC GGC AGC TCG TG -3'	26	95
-617F wt	5'-TGG GAG TTC AGA GGA GGG CGT TCA GGG TGA CTG CGA ACA CGA GCT GCC GGC GCT GTC CAC AT-3'	62	95
-617R wt	5'-ATG TGG ACA GCG CCG GCA GCT CGT GTT CGC AGT CAC CCT GAA CGC CCT CCT CTG AAC TCC CA -3'	62	95
-617F var	5'-TGG GAG TTC AGA GGA GGG CGT TCA GGG TGA CTG CGA ACA CGA GCT GCC GGA GCT GTC CAC AT-3'	62	95
-617R var	5'-ATG TGG ACA GCT CCG GCA GCT CGT GTT CGC AGT CAC CCT GAA CGC CCT CCT CTG AAC TCC CA -3'	62	95

**Table 3. Allelic frequencies of NRF2 promoter polymorphisms in four ethnic groups.**

\*ND = Not Detected

<b>Allele</b>	<b>European (%)</b>	<b>African (%)</b>	<b>Asian (%)</b>	<b>Native American (%)</b>
-617A	20.0	10.0	55.0	40.0
-651A	10.0	5.0	ND*	ND
-653G	25.0	10.0	40.0	60.0

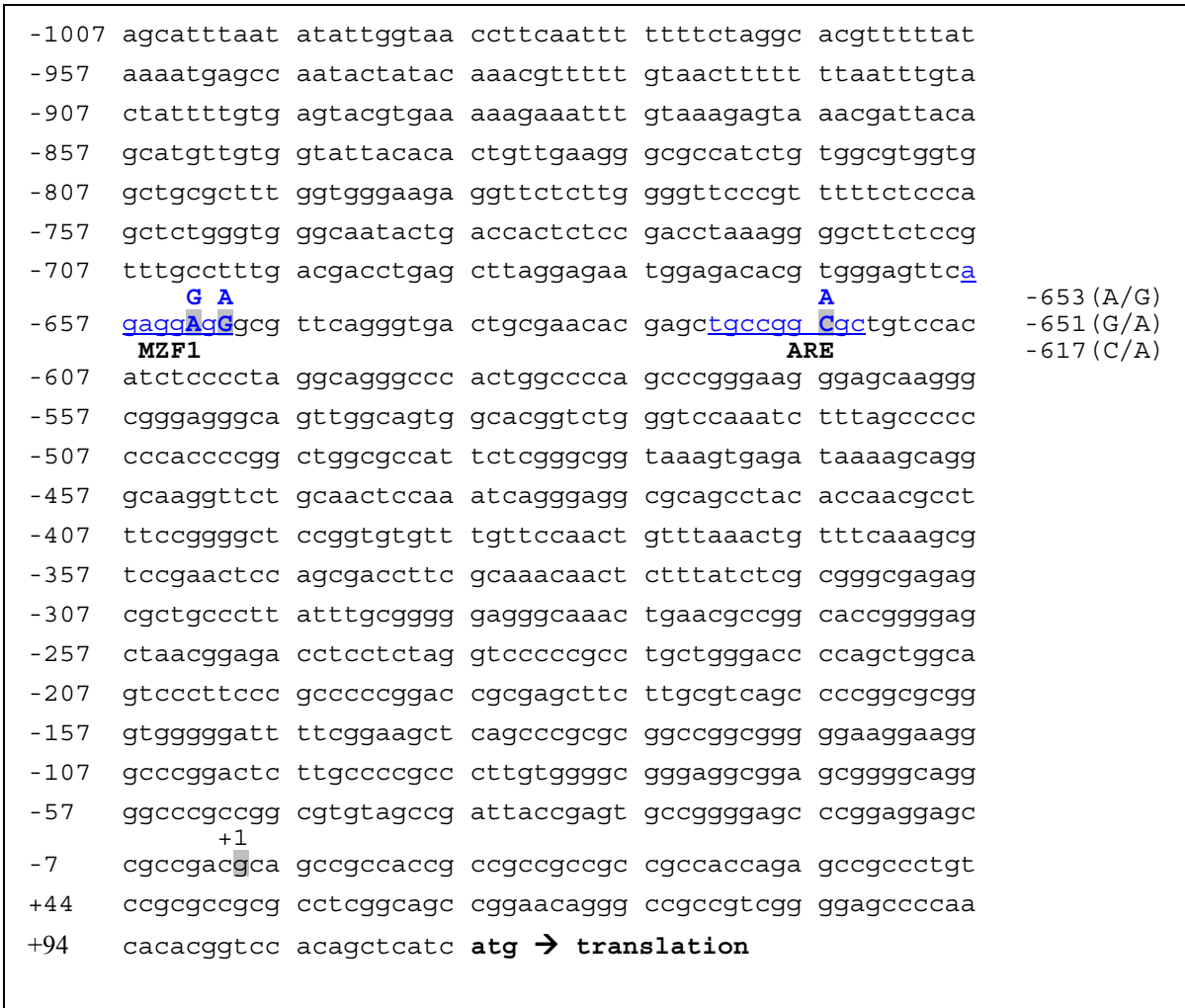

**Figure 1. Identification of polymorphisms in NRF2.** Part of the human NRF2 promoter sequence (wildtype sequence shown). Three novel polymorphisms at positions -653 (A/G), -651 (G/A), and -617 (C/A) are indicated in capital letters. Putative binding sites for MZF1 (AGAGGAGG) and NRF2 (TGCCGGCGC) are underlined in blue, the transcriptional start site is highlighted, and the ATG start codon is in bold.

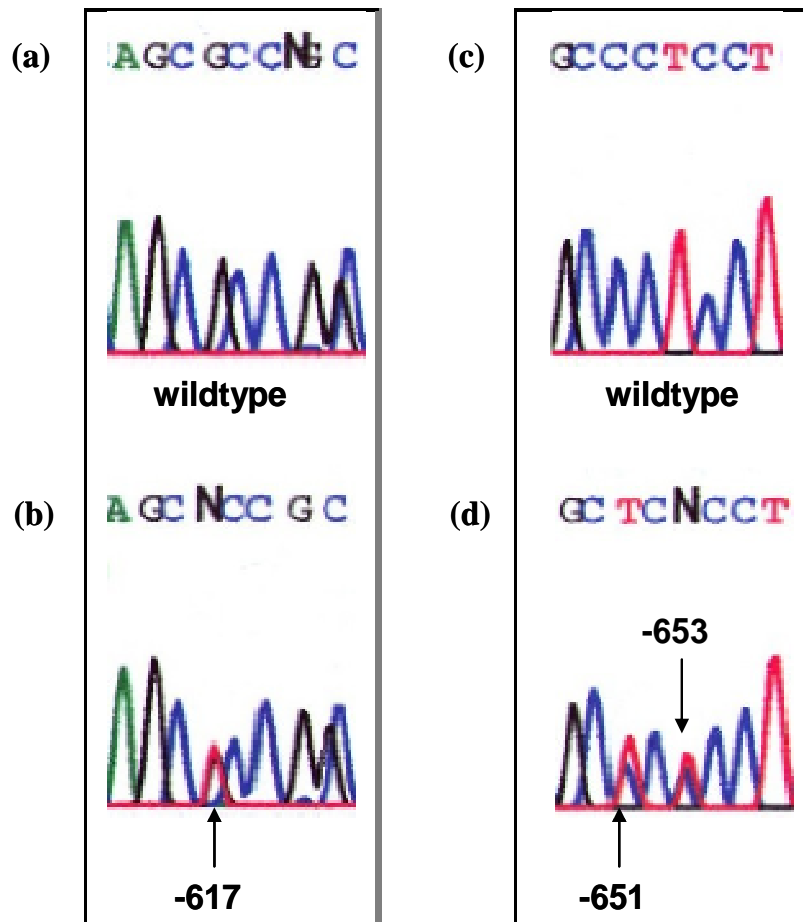

**Figure 2. Representative electropherograms of *NRF2* promoter polymorphisms between -656 to -614 (reverse strand shown). (a) -617 GG (b) -617 GT (c) -651 CC and -653 TT (d) -651 CT and -653 TC.**

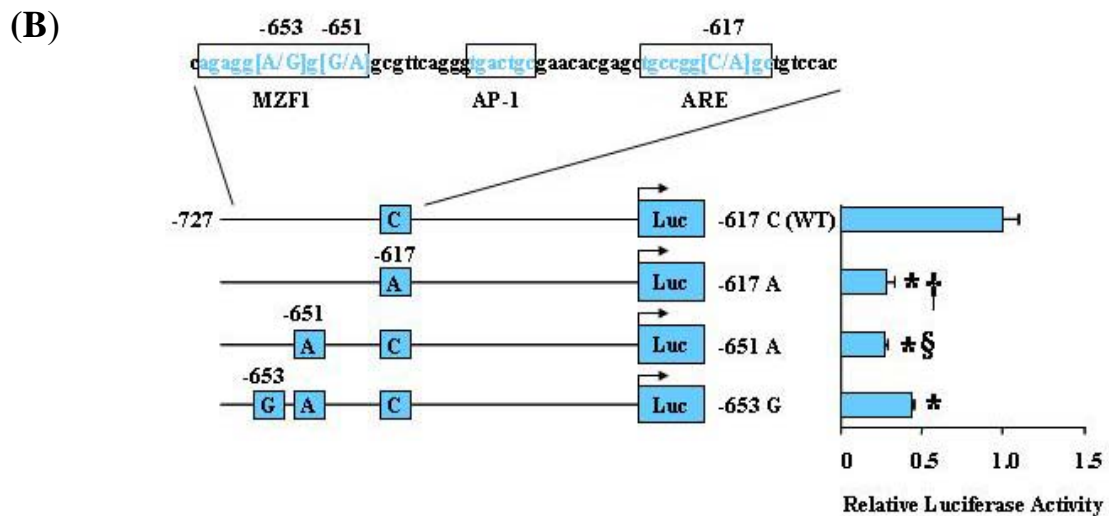
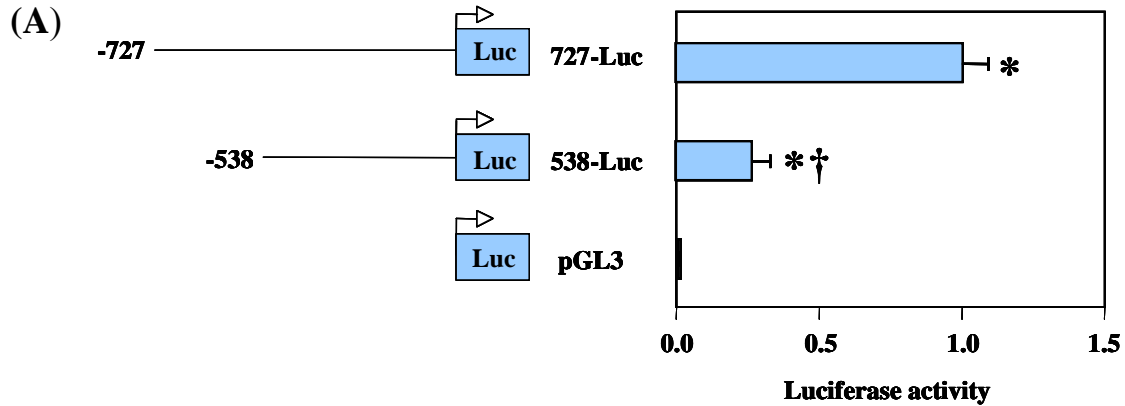

**Figure 3. NRF2 promoter polymorphisms decrease functional activity.** (A) Luciferase activity of two *NRF2* promoter constructs: 727-Luc containing the SNP region, and 538-Luc without the SNP region, compared to pGL3 vehicle control. Intact promoter with the polymorphic region exhibited four-fold higher luciferase activity compared to the 538-Luc reporter. \*,  $P < 0.05$  compared with pGL3; †,  $P < 0.05$  compared with 727-Luc. (B) Luciferase activity of four *NRF2* promoter constructs: -617C (wildtype sequence, 727-Luc), -617A, -651A and -653G. Remaining SNP sites are indicated when double variants are used. The wildtype 727-Luc reporter exhibited over 50% higher luciferase activity compared to polymorphic variants. \*,  $P < 0.05$  compared with pGL3; †, §,  $P < 0.05$  compared with 727-Luc.

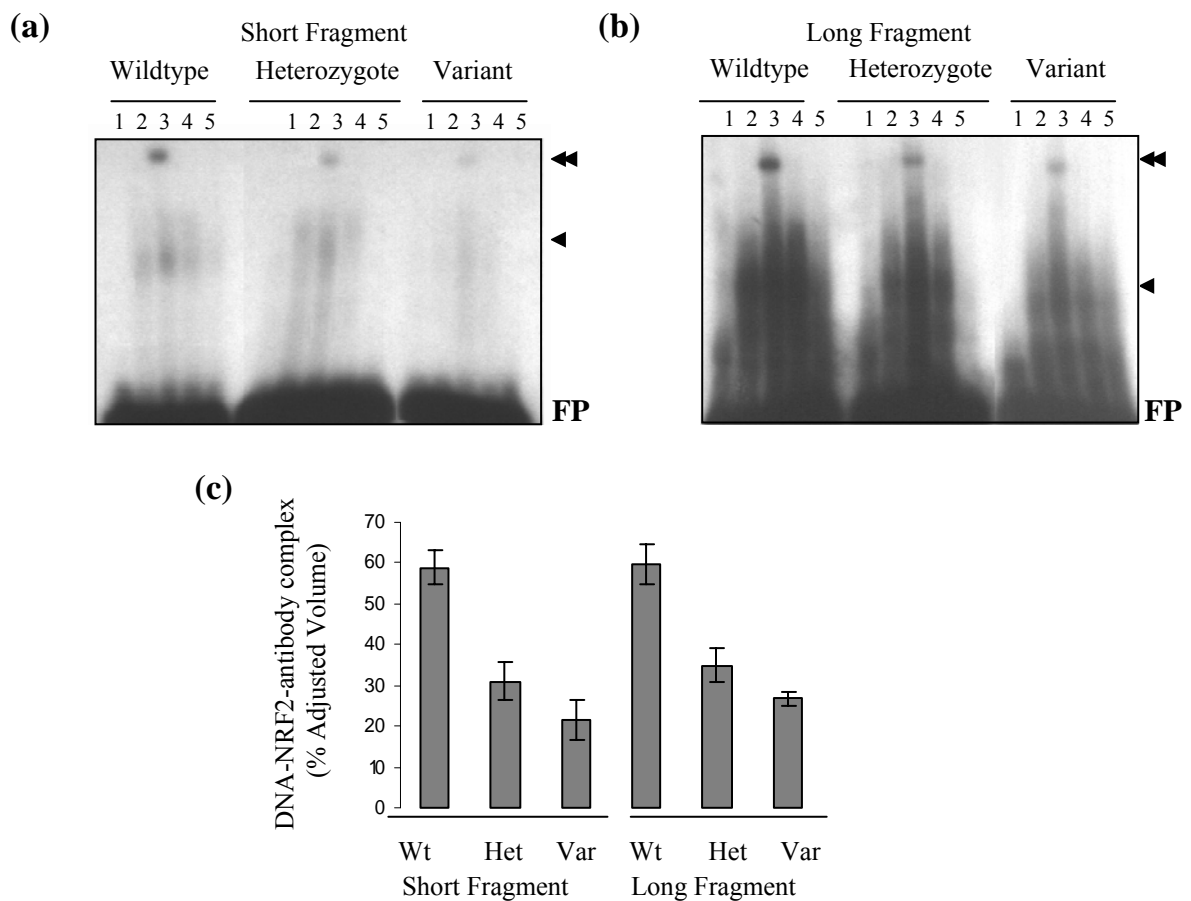

**Figure 4. Electrophoretic mobility shift assays (EMSA) to evaluate effects of the -617 polymorphism on protein-DNA complex formation.** (a) 26 bp wildtype, heterozygote and homozygous variant oligonucleotides (short fragment) spanning the -617 polymorphic region. (b) 62 bp wildtype and heterozygote oligonucleotides (long fragment) spanning the -617 polymorphic region. Lane 1 free probe; lane 2 reaction without antibody; lane 3 reaction with anti-NRF2 antiserum (2  $\mu$ l); lane 4 rabbit control IgG (2  $\mu$ l); and lane 5 competition without antibody (40 X). The double arrowhead indicates the supershifted bands (DNA-NRF2-antibody complex), and the single arrowhead indicates the shifted bands (DNA-nuclear protein complex). FP, free probe. (c) Densitometry results for supershifted bands (DNA-NRF2-antibody complex) represented as percent adjusted volume for the short and long fragments. Mean ( $\pm$  SEM) of three separate experiments are presented.

## References

- Cho, H.-Y., Reddy, S.P., Debiase, A., Yamamoto, M., Kleeberger, S.R. (2005). "Gene expression profiling of NRF2-mediated protection against oxidative injury." Free Radical Biology and Medicine **38**(3): 325-343.
- Cho, H., Jedlicka, A.E., Reddy, S.P., Kensler, T.W., Yamamoto, M., Zhang, L.Y., Kleeberger, S.R. (2002). "Role of NRF2 in protection against hyperoxia lung injury in mice." American Journal of Respiratory Cell and Molecular Biology **26**(2): 175-182.
- Erickson, A. M., Neverea, Z., Gipp, J.J., Mulcahy, R.T. (2002). "Identification of a variant antioxidant response element in the promoter of the human glutamate-cysteine ligase modifier subunit gene." Journal of Biological Chemistry **2002**(34): 30730-30737.
- Gerristen, M. E., Williams, A.J., Neish, A.S., Moore, S., Shi, Y., Collins, T. (1997). "CREB-binding protein/p300 are transcriptional coactivators of p65." Proceedings of the National Academy of Sciences, USA **94**: 2927-2932.
- Grossman, S. R. (2001). "p300/CBP/p53 interaction and regulation of the p53 response." European Journal of Biochemistry **268**: 2773-2778.
- Heinemeyer, T., Wingender, E., Reuter, I., et al (1998). "Databases on transcriptional regulation: TRANSFAC, TRRD and COMPEL" Nucleic Acids Research **26**: 362-367.
- Kamei, Y., Xu, L., Heinzl, T., Torchia, J., Kurokawa, R., Gloss, B., Lin, S.C., Heyman, R.A., Rose, D.W., Glass, C.K., Rosenfeld, M.G. (1996). "A CBP integrator complex mediates transcriptional activation and AP-1 inhibition by nuclear receptors." Cell **85**: 403-414.
- Karin, M., Ben-Neriah, Y. (2000). "Phosphorylation meets ubiquitination: the control of NF-[kappa]B activity." Annual Reviews of Immunology **18**: 621-663.
- Kwak, M. K., Itoh, K., Yamamoto, M., Kensler, T.W. (2002). "Enhanced expression of the transcription factor Nrf2 by cancer chemopreventive agents: role of the antioxidant response element-like sequence in the nrf2 promoter." Molecular and Cellular Biology **22**(9): 2883-2892.
- Kwok, R. P., Lundblad, J.R., Chrivia, J.C., Richards, J.P., Bachinger, H.P., Brennan, R.G., Roberts, S.G., Green, M.R., Goodman, R.H. (1994). "Nuclear protein CBP is a coactivator for the transcription factor CREB." Nature **370**: 223-226.
- Lee, J. W., Lee, Y.C., Na, S.Y., Jung, D.J., Lee, S.K. (2001). "Transcriptional coregulators of the nuclear receptor superfamily: Coactivators and corepressors." Cellular and Molecular Life Sciences **58**: 289-297.

Liptay, S., Schmid, R.M., Nabel, E.G., Nabel, G.J. (1994). "Transcriptional regulation of NF-kappa B2: evidence for kappa B-mediated positive and negative autoregulation." Molecular and Cellular Biology **14**(12): 7695-7703.

Mander, A. (2000). "Haplotype frequency estimation using an EM-algorithm and log-linear modeling." Stata Technical Bulletin **57**: 5-7.

N Wakabayashi, K. I., J Wakabayashi, H Motohashi, S Noda, S Takahashi, S Imakado, T Kotsuji, F Otsuka, DR Roop, T Harada, JD Engel, M Yamamoto (2003). "Keap1-null mutation leads to postnatal lethality due to constitutive Nrf2 activation." Nature Genetics **35**(3): 202-204.

Nguyen, T., H. H., Pickett, C.B. (2000). "Transcriptional regulation of the antioxidant response element. Activation by Nrf2 and repression by MafK." Journal of Biological Chemistry **275**(20): 15466-15473.

Nguyen, T., Yang, C.S., Pickett, C.B. (2004). "The pathways and molecular mechanisms regulating Nrf2 activation in response to chemical stress." Free Radical Biology and Medicine **37**(4): 433-441.

Okada, S., Obata, S., Hatano, M., Kokuhisa, T. (2003). "Dominant-negative effect of the c-fos family gene products on inducible NO synthase expression in macrophages." International Immunology **15**(11): 1275-1282.

Wakabayashi, N., Itoh, K., Wakabayashi, J., Motohashi, H., Noda, S., Takahashi, S., Imakado, S., Kotsuji, S., Otsuka, F., Roop, D.R., Harada, T., Engel, J.D., Yamamoto, M. (2003). "Keap1-null mutation leads to postnatal lethality due to constitutive Nrf2 activation." Nature Genetics **35**(3): 202-204.

Yamamoto, T., Yoh, K., Kobayashi, A., Ishii, Y., Kure, S., Koyama, A., Sakamoto, T., Sekizawa, K., Motohashi, H., Yamamoto, M. (2004). "Identification of polymorphisms in the promoter region of the human NRF2 gene." Biochemical and Biophysical Research Communications **321**(1): 72-79.

Zhang, J. J., Vinkemeier, U., Gu, W., Chakravarti, D., Hovarth, C.M., Darnell, J.E. (1996). "Two contact regions between Stat1 and CBP/p300 in interferon gamma signaling." Proceedings of the National Academy of Sciences, USA **93**: 15092-15096.

## **Chapter 2**

### **Effects of the NRF2 ARE polymorphism on downstream antioxidant transcription**

**Rationale:** Previous functional studies have shown significant reductions in *NRF2* transcriptional activity associated with mutations to the ARE sequence. Using an *in vitro* exposure system, we determined basal and inducible mRNA expression of *NRF2* and downstream antioxidants in wildtype and *NRF2* -617 polymorphic cell lines. **Methods:** Lymphoblasts were maintained in serum complete media (10% FBS) or serum starved media (0.5% FBS) for 24 hours prior to exposure. The following day, serum complete cells were exposed to hyperoxia for 0, 4 and 8 hours, 100 µg/ml LPS for 0, 3 and 6 hours, or 25 µM BHT for 0, 8 and 24 hours. Serum starved cells were exposed to hyperoxia, 100 µg/ml LPS, or 25 µM BHT for 0, 0.5, 1 and 2 hours. Cells were harvested, spun down, collected on ice and washed twice with cold 1X PBS. RNA was extracted, quantitated and converted to cDNA. *NRF2* and downstream antioxidant expression of *NQO1*, *HO1*, *GPx2* and *GSR* was assessed with semi quantitative RT-PCR and quantitative real time PCR, and internal loading controls were included for normalization. **Results:** Serum starved *NRF2* heterozygote cells exposed to hyperoxia and LPS had significantly higher basal and inducible expression of *NRF2*, *NQO1* and *HO1* compared to wildtype and -617 variant cells. Similarly, significant *NRF2* induction was observed in serum complete *NRF2* heterozygote cells exposed to hyperoxia with concomitant increased *GPx2* expression. BHT exposure produced significant changes in *GPx2* expression between *NRF2* genotypes, both for serum complete and serum starved cells. **Conclusions:** Serum starvation exacerbates oxidative stress induced by hyperoxia and LPS, inducing *NRF2* expression which activates *NQO1* and *HO1*. Variability in basal and inducible expression exists in *NRF2* heterozygotes in comparison to wildtype and variant cells. Heterozygosity produces higher levels of transcripts for *NRF2*, *NQO1* and *HO1* and *GPx2*, which could potentially impact translation and stability of *NRF2* and upregulated antioxidant proteins.

## Introduction

Induction of the ARE gene battery largely depends on coordinated regulatory mechanisms to increase Nrf2 protein levels and promote its subcellular accumulation in the nucleus to drive transcription. Phosphorylation by protein kinases is believed to be the major post-translational mechanism regulating Nrf2 protein stability. Post-translational modifications may also dictate its transactivation potential, DNA-binding affinity, and subsequent interactions with other transcription factors or components of the basal transcription complex (Nguyen 2004). The turnover rate of intracellular proteins is often determined by their rate of proteasomal degradation, and could constitute another means to regulate *Nrf2* transcriptional activity. Although the majority of studies have found that post-translational mechanisms lead to elevated Nrf2 protein levels (Motohashi 2002; Owuor 2002; Ben-Dor 2005), upregulation of *Nrf2* gene expression at the transcriptional level has also been reported as a means to increase amounts of Nrf2 in cells in response to ARE inducers (Kwak 2002). Under certain conditions, the level of *Nrf2* mRNA is increased by a positive feedback mechanism originating at the ARE in the promoter region of *nrf2*.

Many proteins whose cellular expression is ARE-mediated are critical regulators of cellular redox homeostasis. NQO1, HO1, and GSTs detoxify harmful intermediates of oxidative stress such as quinones, heme-containing complexes and lipid peroxidation products. Initial *Nrf2* gene deletion studies by Itoh *et al* (1997) indicated the importance of Nrf2 in downstream ARE transactivation. BHA induced expression of four *gst* subunits and *nqo1* in *nrf2*<sup>+/+</sup> mice, whereas induction was significantly attenuated in *nrf2*<sup>-/-</sup> mice (Itoh 1997). The sequence context of downstream ARE gene targets represent an additional means of regulatory complexity in the antioxidant response.

Mutation of the ARE can impact binding of transcription factors, or preclude binding by coactivators of the antioxidant response. In transient transfection studies by Wang *et al* (2006) mutation of the *NQO2* ARE significantly inhibited expression and diminished induction in response to tBHQ. Mutation of the core TGACnnnGC sequence caused marked abrogation and a significant loss of basal and inducible expression following treatment (Wang 2006). Studies by Liby *et al* (2005) of synthetic triterpenoids indicated potent activation of *nrf2* signaling and ARE-mediated induction of *HO1*. Moreover, the promoter region of human *HO1* contains a functional ARE and a CREB binding site, and both

regulatory elements are required for induction. Transient transfection of a point-mutant to the core ARE sequence (G to A) or deletion of the entire CRE site reduced reporter activity by 45% and 60%, respectively (Liby 2005). Mutations to both the ARE and CREB binding sites significantly diminished transcriptional activity by 85%. Partial reduction of antioxidant activity can significantly impact the cytoprotective capacity of cells to respond to chemical or environmental exposures.

Along with the ARE sequence context, the nature of the chemical inducer often determines activity of specific ARE-bearing genes (Nguyen 2000). Suppressed basal and inducible expression of *cat*, *sod1*, *nqo1*, and *gclc* was seen in *nrf2*<sup>-/-</sup> mice exposed to BHT (Chan 1999). Studies by Cho *et al* (2005) found that compared to *nrf2*<sup>+/+</sup> mice, *nrf2*<sup>-/-</sup> mice exposed to hyperoxia had decreased Nrf2-DNA binding activity which resulted in significantly diminished expression of antioxidant enzymes such as *gst*, *nqo1*, *ho1* and *gpx2*. Li *et al* (2004) identified Nrf2 as a key regulator of *ho1* expression in mice exposed to diesel exhaust particles. Induction of antioxidant pathways in macrophages and epithelial cells was dependent on the accumulation of polar and aromatic chemical moieties which interfered with proteasomal degradation of Nrf2 (Li 2004). Moreover, in response to DEP, de novo synthesized Nrf2 escaped Keap1-inhibition and translocated to the nucleus of stimulated cells (Li 2004).

Transcriptional activation of ARE-responsive genes  $\gamma$ -*gcs<sub>h</sub>* and  $\gamma$ -*gcs<sub>l</sub>*, *gpx2* was significantly reduced in *nrf2* deficient animals (Wild 1999; Nguyen 2000; Banning 2005). Basal levels of  $\gamma$ -*gcs<sub>h</sub>* were similar in wildtype and *nrf2*<sup>-/-</sup> mice, but following exposure to BHA,  $\gamma$ -*gcs<sub>h</sub>* expression in *nrf2*<sup>-/-</sup> mice was significantly reduced (Banning 2005). Similarly, basal expression of *gpx2* was significantly decreased in the intestine of *nrf2*<sup>-/-</sup> mice (Banning 2005). *In vivo* exposure to either hyperoxia or bleomycin did not induce activation of *gpx2*, suggesting specificity of the chemical or environmental agent in antioxidant regulation (Banning 2005).

The particular cell type also determines activity of a particular ARE-bearing gene (Nguyen 2000). DNA footprint analysis of the rat *gsta2* and *nqo1* gene promoters supports the concept of differential ARE regulation based on gene target and cell type. DNase-I protection patterns from nuclear extracts produced from human HepG2 or rat H4IIE cells had

dissimilar patterns of protection for the two genes (Nguyen 2000). Similarly, a synthesized MafK:Nrf2 complex bound the *nqo1* ARE with higher affinity compared to the *gsta2* ARE.

Studies of *nrf2* dominant-negative mutants further substantiate its role in cellular redox homeostasis. In transient transfection studies of an *nqo1* ARE reporter construct in HepG2 cells exposed to tBHQ and lycopene, *nqo1* ARE induction was inhibited in an *nrf2* dominant-negative mutant lacking transactivation domains (Ben-Dor 2005). As a consequence, *nqo1* mRNA levels were reduced to 70% and 50%, respectively, with negative effects of the dominant-negative mutant even more apparent at the protein level. Similar results were observed with three other cell clones transiently transfected with either wildtype *nrf2* or the dominant-negative mutant (Ben-Dor 2005). Interestingly in wildtype cells expressing normal *nrf2*, induction of *nqo1* mRNA by tBHQ and lycopene was not accompanied by a significant change in *nrf2* mRNA. Because Nrf2 protein turnover occurs so rapidly, a transient mRNA signal could have been missed. The redox-insensitive Neh6 degron may mediate rapid proteasomal degradation in the nucleus following induction of antioxidants. Similarly, additional transcription factors or dissociation of Maf itself may downregulate Nrf2 after transactivation of ARE-bearing genes. Any of these mechanisms can contribute to rapid proteasomal turnover and could prevent detection of peak protein production.

Constitutive activation of *nrf2* and induction of ARE-bearing genes can have detrimental consequences. Studies by Wakabayashi *et al* (2003) found that *keap1*<sup>-/-</sup> mice had constitutive activation of *nrf2* and overproduction of ARE target genes which caused esophageal/forestomach hyperkeratosis, preventing milk absorption and resulting in early death. *Keap1*-mediated repression represents an important mechanism to keep Nrf2 sequestered and transcriptionally inactive at rest.

Nrf2 is ubiquitously expressed in a variety of tissues and cell lines and is responsible for low-level expression of target antioxidant genes under physiological conditions. Activation of Nrf2 is regulated by Keap1 repression in the cytoplasm and protein turnover by the proteasome. Oxidative stress provides a stabilizing mechanism that allows Nrf2 to translocate to the nucleus, and form the Maf-Nrf2 complex for enhanced binding to ARE target genes. Exposure to oxidative stress increases Nrf2 activity and drives transactivation of redox-sensitive genes necessary for homeostatic regulation.

Expression studies of downstream antioxidant induction have focused on complete ablation of *nrf2*. Our functional studies have shown that alterations in the *NRF2* ARE affect functional activity which may affect downstream antioxidant expression. Diminished antioxidant induction and impaired ability to counteract oxidative stress could increase an individual's risk of lung diseases such as ARDS or acute lung injury. Point mutations in the promoter and coding regions of numerous genes have been implicated in a variety of diseases such as Alzheimers, cardiovascular disease and type II diabetes (Martin 2000; Kubaszek 2003; Miller 2005). Similarly, mutations to response elements may enhance susceptibility to oxidative stress by interfering with NRF2-mediated transactivation of protective antioxidant gene targets. Whether the ARE mutation in NRF2 affects downstream gene regulation in an analogous manner is unclear and deserves further analysis. The present study was designed to investigate activation of *NRF2* in response to three separate oxidant exposures (hyperoxia, BHT and LPS) and its effects on downstream gene induction of *NQO1*, *HO1*, *GPx2* and *GSR*, each of which contain one or more functional AREs.

## **Materials and Methods**

### ***In vitro techniques and exposures***

Lymphoblast cell lines were purchased from the Coriell Repository (Camden NJ) and maintained at 37°C in RPMI media (Gibco BRL, Carlsbad CA) supplemented with 10% (v/v) heat-inactivated fetal bovine serum and 1% penicillin-streptomycin (Sigma, St. Louis MO). Cells were grown to 70-80% confluence in 75 cm<sup>2</sup> flasks prior to exposure to 95% oxygen [0, 4, and 8 hours] (National Welders, Charlotte NC), 100 µg/ml LPS [0, 3, and 6 hours] (Sigma, St. Louis MO) or 25 µM BHT [0, 8, and 24 hours] (Sigma, St. Louis MO). Doses for LPS were taken from the literature (Gayle 2002; Wang 2005), and doses for BHT were established by dose response.

Quiescent cells were maintained at 37°C in RPMI media supplemented with 0.5% (v/v) heat-inactivated fetal bovine serum and 1% penicillin-streptomycin for 24 hours prior to exposure. The following day cells grown in 75 cm<sup>2</sup> flasks were exposed to either 95% oxygen, 100 µg/ml LPS or 25 µM BHT for 0, 0.5, 1, and 2 hours.

### ***RNA isolation and cDNA synthesis***

Total RNA was isolated from cells using the RNeasy Mini kit (Qiagen, Valencia CA) and characterized using a Beckman Coulter D640 spectrophotometer for purity and concentration. One microgram ( $\mu\text{g}$ ) total RNA was reverse transcribed into cDNA in a volume of 50  $\mu\text{l}$ , containing 1X PCR buffer [50 mM KCl and 10 mM Tris(pH 8.3)], 5 mM  $\text{MgCl}_2$ , 1 mM dNTPs, 125 ng oligo(dT)<sub>15</sub>, and 50 U of MMLV-RT (Invitrogen, Carlsbad CA), and cycling conditions consisted of 45°C for 15 min, followed by 95°C for 5 min.

### ***Semi-quantitative RT-PCR analysis of gene expression***

Samples were amplified in triplicate using 2  $\mu\text{l}$  aliquots of cDNA in a total volume of 25  $\mu\text{l}$  containing 1X PCR buffer, 4 mM  $\text{MgCl}_2$ , 400  $\mu\text{M}$  dNTPs, 1.25 U *Taq* DNA Polymerase (Invitrogen, Carlsbad CA), and 240 nM each of forward and reverse primers (Table 4) specific to each target gene. Cyclophilin was used as an internal control for loading differences. PCR conditions consisted of initial denaturation for 5 min at 95°C, followed by 28 to 35 cycles of 95°C for 30s, annealing at 55-60°C for 30s and extension at 72°C for 1 to 2 minutes, and a final extension step at 72°C for 10 min. Annealing and extension cycling conditions were optimized for each primer pair to ensure amplification products did not reach saturation. Products were separated on 2% agarose gels containing ethidium bromide and the volume of each band was quantitated using a Gel Doc 2000 system (BioRad, Hercules CA). The adjusted volume ratio of each target gene cDNA to cyclophilin cDNA was calculated for analysis.

### ***Quantitative real-time RT-PCR analysis***

Samples were amplified in triplicate using 1  $\mu\text{l}$  aliquots of cDNA in a total volume of 20  $\mu\text{l}$  containing 2X universal master mix (Applied Biosystems, Foster City CA) and 20X assays-on-demand prequalified primer-probe set specific to each gene. Sybr assays consisted of 1  $\mu\text{l}$  cDNA, 10  $\mu\text{l}$  Power Sybr master mix, and 200 nM each forward and reverse primer (Table 1) for a total volume of 20  $\mu\text{l}$ . Standard cycling conditions were used for both probe-based and Sybr assays consisting of 50°C for 2 min, 95°C for 10 min, followed by 40 cycles of 95°C for 15 sec and 60°C for 1 min. Products were analyzed using the ABI 7000 Sequence Detection System software, and the threshold set to capture the upper two-thirds of amplification. Cycle threshold (Ct) values were analyzed using the  $2^{-\text{ddCt}}$  method reported by Pfaffl (Pfaffl 2004).

### ***Statistical analysis***

Differences between groups were tested by two-way analysis of variance (ANOVA) followed by Student-Newman-Keuls (SNK) *a posteriori* comparison of means (Sigma Stat, Jandel Scientific Software, San Rafael CA). Data sets that were not normally distributed were tested non-parametrically using Friedman's repeated measures ANOVA on ranks followed by SNK *a posteriori* comparison. A two-sided p-value of less than 0.05 was considered statistically significant. All normalized fold changes in transcription were calculated from wildtype air or vehicle alone.

### **Results and Discussion**

Exposures times were selected for optimal expression changes. Previous expression studies have shown that antioxidants are induced within 2 hours and return to basal levels within 4 to 8 hours (Kazzaz 1999; Nguyen 2004; Cho 2005). Because antioxidant expression is rapidly induced, shorter 2 hour time courses were used to estimate transient expression changes that occur in response to oxidative stress. Longer exposures were established for each agent in order to study inducible activity as it returns to baseline.

### ***Hyperoxia***

Minor differences in *NRF2*, *NQO1*, and *HO1* expression were observed in serum complete cells after 4 hours of hyperoxia (Figures 1 and 2). In comparison to air exposed cells, after 8 hours of treatment, *NRF2*, *NQO1*, and *GPx2* expression in *NRF2* wildtype cells was significantly reduced. Statistically significant reductions in *HO1* and *GSR* expression were noted in *NRF2* heterozygote and variant cells at 8 hours, whereas *GPx2* was significantly induced in the same cells after hyperoxia exposure (Figure 2).

In contrast to serum complete cells, serum starvation followed by short term *in vitro* exposure to hyperoxia resulted in significant changes in *NRF2* expression as well as transcriptional activity of downstream antioxidants. Significantly higher basal and inducible activity was observed in *NRF2* heterozygote cells for *NRF2* and *HO1* independent of hyperoxia exposure (Figure 3 and 4). *NQO1* expression was 3-fold higher in heterozygotes after exposure compared to wildtype cells, with a statistically significant interaction effect between genotype and treatment (Figure 4). A significant reduction in *GPx2* expression was

observed in *NRF2* heterozygotes exposed to hyperoxia for 0.5 and 2 hours (Figure 4). Similarly, significant reductions in *GPx2* activity were noted in variant cells, independent of exposure. No significant change in *GSR* expression was seen for serum starved cells exposed to hyperoxia

Basal and inducible activity of *NQO1* and *HO1* were similar to *NRF2*, and as previous studies have shown, provide ample evidence of strong transcriptional regulation by *NRF2* (Itoh 1997; Chan 1999; Li 2004; Cho 2005). *NQO1* and *HO1* expression were significantly higher in *NRF2* heterozygotes following hyperoxia exposure, confirming that these antioxidants are upregulated in ARE heterozygotes during oxidative stress. Serum starved *NRF2* heterozygotes have significantly higher basal *NRF2*, *NQO1* and *HO1* activity prior to hyperoxia exposures, which suggests these cells are highly susceptible to oxidative stress.

The lower levels of induction observed in *NRF2* variant cells compared to heterozygotes, although anomalous, could be explained by a heterozygosity effect, whereby two different alleles are present at a given locus. Heterozygosity at the ARE site may stabilize the *NRF2* transcript, allowing higher levels to enter the nucleus to activate specific downstream targets. Previous studies have shown that heterozygosity can provide protection from disease as shown in sickle cell anemia and phenylketonuria (Beckman 1990), or enhance susceptibility to disease as shown for the HLA gene in rheumatoid arthritis (McDonagh 1997). The precise mechanism behind the observed heterozygosity effect is unknown and warrants further study.

### ***Lipopolysaccharide***

Inducible *NRF2* activity of serum complete lymphoblasts was significantly higher in *NRF2* heterozygotes (3-fold) compared to wildtype and variant cells following exposure (Figure 5). Of the downstream antioxidants studied, *GPx2* inducible activity closely resembled that seen for *NRF2*, with a significant increase (1.7-fold) in heterozygote expression at 3 and 6 hours compared to basal levels (Figure 6). *GPx2* activity in variant cells was significantly decreased basally and after 6 hours LPS exposure. *HO1* expression was significantly lower in *NRF2* heterozygote and variant cells basally and throughout

exposure, whereas *GSR* expression was significantly higher in *NRF2* variant cells, independent of LPS treatment (Figure 6).

Serum starvation resulted in disproportionately high basal *NRF2* expression in *NRF2* heterozygotes (3-fold) compared to wildtype and variant cells. After LPS exposure for 1 hour, *NRF2* expression was also significantly induced in wildtype and variant cells (Figure 7). As seen in serum starved cells exposed to hyperoxia, similar patterns of induction were observed for *NRF2*, *NQO1* and *HO1* expression, suggesting they are *NRF2* regulated (Figure 7 and 8). *HO1* expression was comparable to *NRF2*, with expression in *NRF2* heterozygotes above 2.4-fold at all time points, however, *NQO1* expression in heterozygotes was not as impressive (1.7 fold higher basally and showed only low-level induction). *GPx2* expression was significantly reduced in wildtype cells after exposure, however no significant differences in expression were observed between *NRF2* genotypes (Figure 8). *GSR* activity was not changed by short-term LPS exposure.

Exposure to LPS following serum starvation followed a similar induction pattern as seen for hyperoxia with serum starvation. Serum starvation alone can stress cells, and may also affect transcriptional activity of oxidative stress genes, as seen in *NRF2* heterozygotes. In contrast to hyperoxia exposures, inducible activity of LPS-exposed *NRF2* heterozygote cells did not differ from basal levels, suggesting these cells are either unaffected by LPS, or cannot activate downstream targets. *NRF2*, *NQO1* and *HO1* gene induction increased moderately in *NRF2* variants and wildtype cells in response to hyperoxia and LPS, and suggests that *NRF2* may regulate expression of these genes.

### ***Butylated hydroxytoluene***

No significant changes in inducible *NRF2* activity were observed between *NRF2* genotypes after BHT exposure for 24 hours; however, *NRF2* heterozygote cells were significantly higher basally compared to wildtype and variant cells (Figure 9). *NQO1* expression most closely resembled that of *NRF2*, and activity was significantly reduced in *NRF2* heterozygote and variant cells after 24 hours of treatment (Figure 10). *HO1* expression was significantly reduced in *NRF2* variants basally and after 24 hours of exposure (Figure 10). Significantly higher *GPx2* expression was observed in *NRF2* heterozygotes for all time points, with 12-fold higher levels seen basally, increasing up to almost 20-fold within

24 hours (Figure 10). Because of the large induction observed, the assay was repeated for verification and results were highly concordant. *GSR* expression was significantly reduced in heterozygote cells throughout the time course, and was also decreased in *NRF2* variant cells after 24 hours (Figure 10).

*NRF2* was significantly induced in wildtype serum starved cells after BHT treatment for 1 hour (Figure 11). *NRF2* heterozygote and variant cells had significantly lower *NRF2* activity after BHT treatment compared to wildtype cells. *NQO1* and *HO1* expression were reduced in all cells after BHT treatment for 2 hours (Figure 12). *GSR* expression was significantly (2.5-fold) higher in heterozygotes basally, and decreased in *NRF2* heterozygote and variant cells over the time course (Figure 12). Significantly increased *GPx2* expression was observed for wildtype cells in comparison to *NRF2* heterozygotes and variants, both basally and after BHT exposure. Levels were barely detectable in heterozygotes and variants, suggesting *GPx2* was not significantly induced in these cells under our exposure conditions.

This is in marked contrast to *GPx2* activation seen in serum complete cells exposed to BHT for 24 hours where *NRF2* heterozygote *GPx2* expression was markedly induced. Such significant increases in *GPx2* expression in *NRF2* heterozygotes could be explained by the protective role of BHT as a free radical scavenger as well as its pro-oxidant functions. In this capacity, the serum starved cells may be protected from ROS overload by the scavenging activity of BHT, while in serum complete cells, BHT acts instead as a pro-oxidant, inducing the strong activation of *GPx2* to counteract oxidative stress. Interestingly the increase in *GPx2* expression in serum complete *NRF2* heterozygote cells may be *NRF2*-independent, perhaps mediated through another transcription factor or through direct interactions with the basal transcription machinery. In contrast to our results, enzymatic studies by Ochi *et al* (1990) did not reveal any effect of BHT on *GPx2* activity and *in vivo* studies by Awasthi *et al* (1983) observed no change in *gpx2* in the livers of BHT-fed rats.

## Summary

Oxidative exposure to LPS and hyperoxia coupled with serum starvation produce transient changes in *NRF2* expression that affect downstream expression of *NQO1* and *HO1*. Stronger activation of *NRF2* was seen in *NRF2* heterozygotes as compared to variant and

wildtype cells, indicating a significant heterozygosity effect. Significantly higher transactivation of *HO1* and *NQO1* was also observed for heterozygotes, suggesting strong *NRF2* regulation. LPS-exposed serum complete cells showed significantly increased *NRF2* activity, with increased *GPx2* expression, whereas BHT exposure produced significantly higher levels of *GPx2* in *NRF2* heterozygote cells independent of *NRF2* activation. Inducible expression is highly dependent on the nature of the oxidative inducer, cell type and as we have shown, the specific sequence context of the *NRF2* ARE.

Potential limitations of our transcription study include bias introduced through selection of cell type, oxidative agent used, as well as dose and length of exposure. Epithelial cells would ideally have been used for these studies because they are highly susceptible to oxidative stress agents, as shown in the literature (Chan 1999; Cho 2002). However, *NRF2* polymorphic epithelial cells were not commercially available at the time of our study. To collect epithelial cells would require screening healthy individuals for *NRF2* promoter SNPs, followed by bronchial lavage to isolate epithelial cells, and creation of primary epithelial cell lines. Because of time limitations and difficulty recruiting volunteers to undergo bronchoscopy, we instead chose commercially available lymphoblast cell lines to study.

Oxidative agents were selected based on previous work by Cho *et al* (2002), Chan *et al* (1999), and Rushworth *et al* (2005), which show significant *NRF2* induction in response to hyperoxia, BHT and LPS, respectively. In our studies we did not see strong *NRF2* activation with hyperoxia or BHT in serum complete lymphoblasts, but did observe significant induction of gene targets in *NRF2* heterozygote serum starved cells exposed to hyperoxia, LPS and BHT. Because lymphoblasts were more resistant to oxidative stress, they required a primary stress (serum starvation) that enhanced susceptibility to oxidative exposure. Increased doses, different exposure times, or other agents such as *t*BHQ or sulforaphane may have greater effects on *NRF2* and antioxidant induction.

Several studies have reported invariant changes in *NRF2* mRNA levels during electrophile treatment (Numazawa 2004; Ben-Dor 2005). In agreement with these observations, the majority of our serum complete exposures did not show significant changes in *NRF2* or downstream antioxidant expression in response to oxidative exposure. Numerous investigators have attempted to correlate mRNA levels with protein expression,

but most studies are inconclusive and limited mainly to yeast. Post-transcriptional alterations to mRNA (splicing, targeting, etc) often determine the abundance and fate of the nascent protein. Multiple post-transcriptional and post-translational modifications occur between initial transcriptional activation and formation of a functional mature protein that mRNA levels may not correlate with protein abundance. Whether the mRNA expression changes we have observed translate into differences in protein expression will be addressed in the next chapter.

**Table 4. Semi-quantitative RT-PCR and quantitative real-time SYBR primers for mRNA expression analysis.**

<b>Gene</b>	<b>RT-PCR primer sequence</b>	<b>Amplified Size (bp)</b>	<b>Annealing Temp (°C)</b>
<i>NRF2</i>	FOR 5'-ACA TTC CCG TTT GTA GAT GA-3' REV 5'-TTA CCC AGA TGT CAT ATC-3'	1768	55
<i>NQO1</i>	FOR 5'-AGA AGA GCA CTG ATC GTA CT-3' REV 5'-TCA TTA AGA ATC CTG CCT GG-3'	859	57
<i>HO1</i>	FOR 5'-AGC ATG CCC CAG GAT TTG TC-3' REV 5'-GAG CTG CTT GAA CTT GGT GG-3'	521	55
<i>GSR</i>	FOR 5'-ACA AGC TGG GTG GCA CTT-3' REV 5'-ATC CCT GCC ATC TCC ACA-3'	459	55
<i>Cyclophilin</i> (loading control)	FOR 5'-CTT GTC CAT GGC AAA TGC TG-3' REV 5'-GTG ATC TTC TTG CTG GTC TTG-3'	300	55

<b>Gene</b>	<b>SYBR primer sequence</b>	<b>Amplified Size (bp)</b>	<b>Annealing Temp (°C)</b>
<i>GPx2</i>	FOR 5'-AGC GCC TCC TTA AAG TTG CCA-3' REV 5'-AAA GGC AAG GCT CTG CAG TGA-3'	<200	60
<i>GSR</i>	FOR 5'-TTG CGT GAA TGT TGG ATG TGT-3' REV 5'-CAC ATA GGC ATC CCG CTT T-3'	<200	60
<i>18S</i> (loading control)	FOR 5'-GCG CCG CTA GAG GTG AAA TT -3' REV 5'-CCG GTC GGC ATC GTT TAT G-3'	<200	60

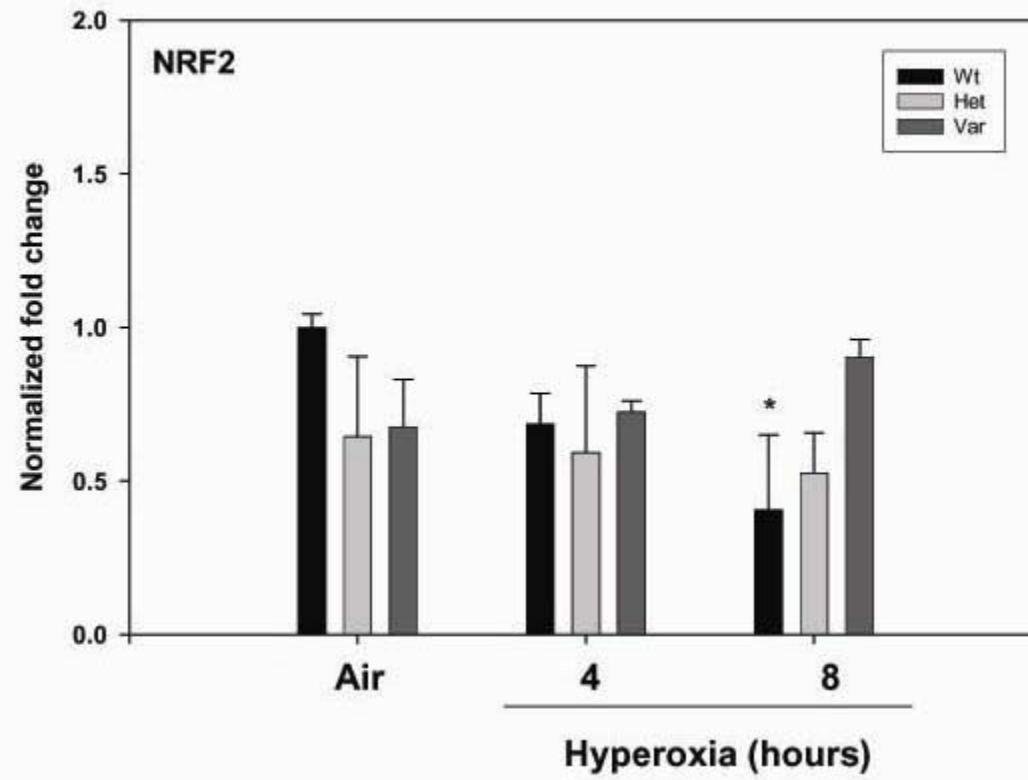

**Figure 1. mRNA expression of polymorphic NRF2 -617 cells exposed to hyperoxia (95% O<sub>2</sub>) for 0, 4 and hours.** mRNA isolated from serum complete lymphoblasts was converted to cDNA and analyzed for *NRF2* gene expression. Legend: Wt = wildtype CC; Het = heterozygote CA; Var = variant AA; \*, P<0.05 compared with air.

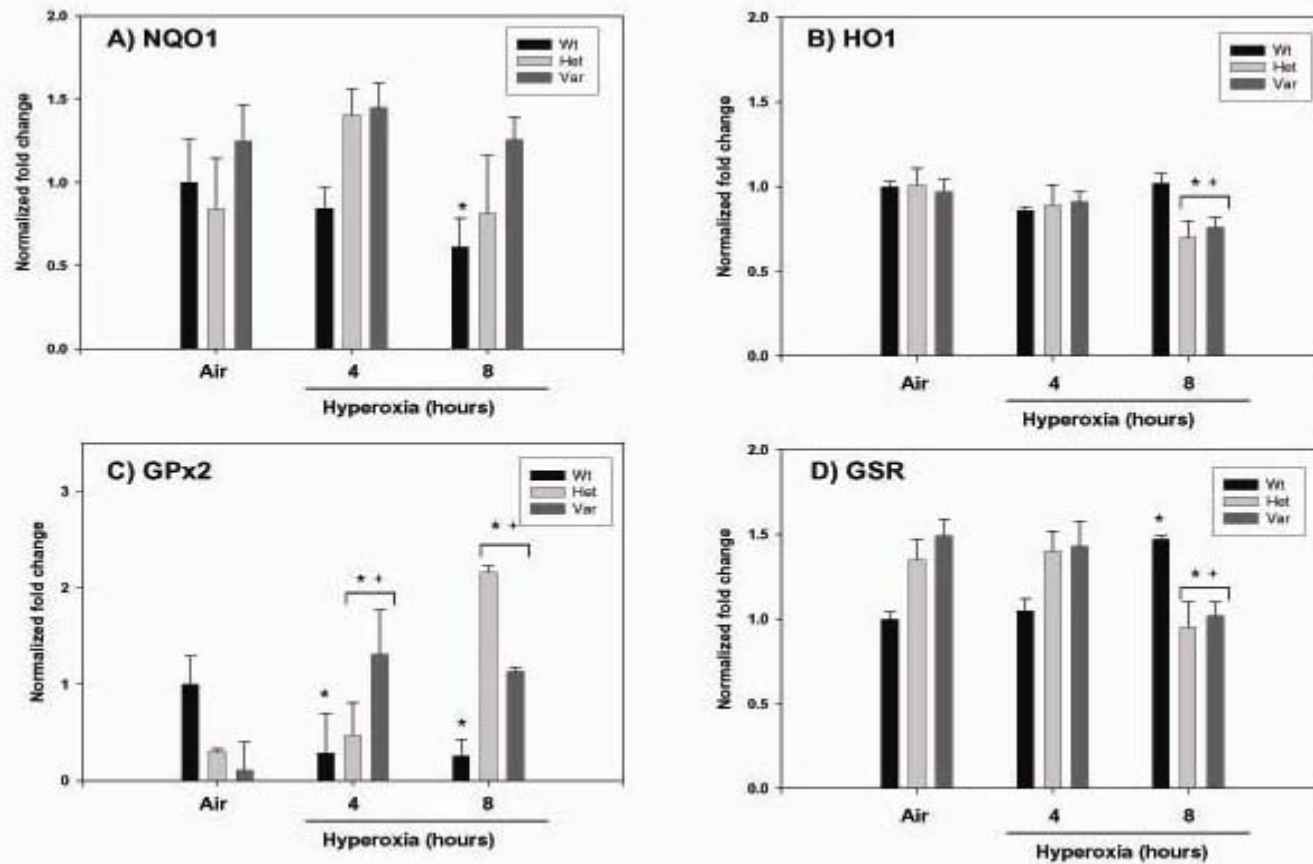

**Figure 2. mRNA expression of polymorphic *NRF2* -617 cells exposed to hyperoxia (95% O<sub>2</sub>) for 0, 4 and 8 hours.** mRNA isolated from serum complete lymphoblasts was converted to cDNA and analyzed for *NQO1* (A), *HO1* (B), *GPx2* (C) and *GSR* (D) gene expression. Legend: Wt = wildtype CC; Het = heterozygote CA; Var = variant AA; \*, P < 0.05 compared with air; +, P < 0.05 compared with wildtype.

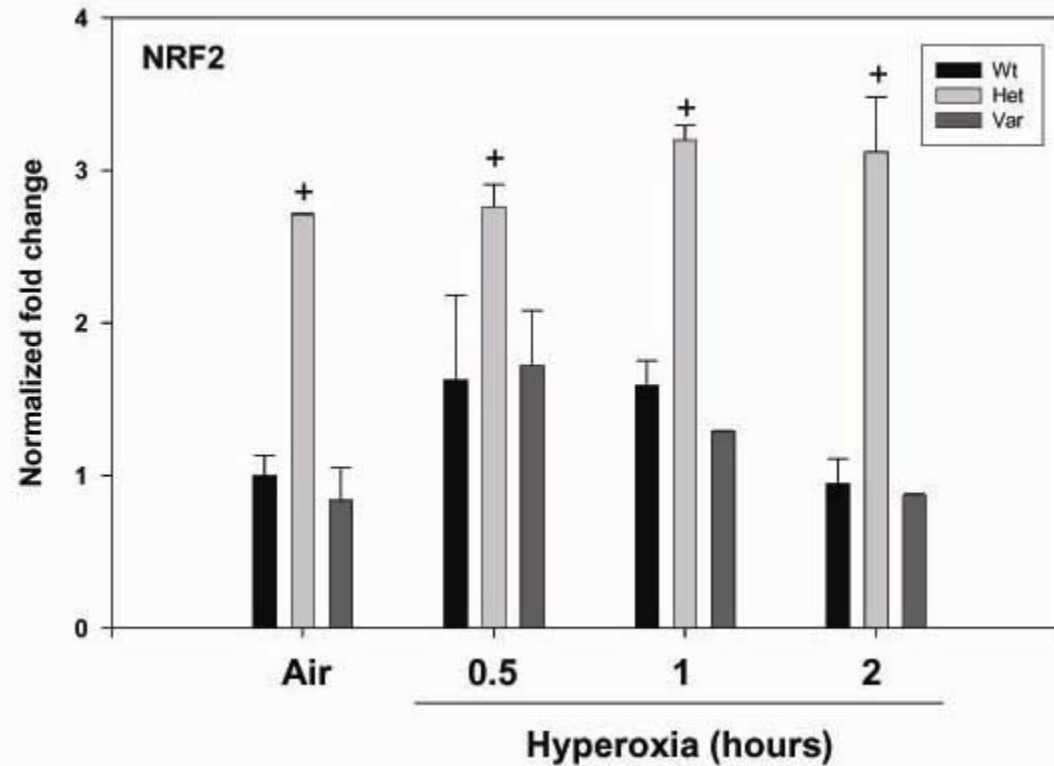

**Figure 3. mRNA expression of polymorphic *NRF2* -617 cells exposed to hyperoxia (95% O<sub>2</sub>) for 0, 0.5, 1 and 2 hours.** mRNA isolated from serum starved lymphoblasts was converted to cDNA and analyzed for *NRF2* gene expression. Legend: Wt = wildtype CC; Het = heterozygote CA; Var = variant AA; +, P<0.05 compared with wildtype.

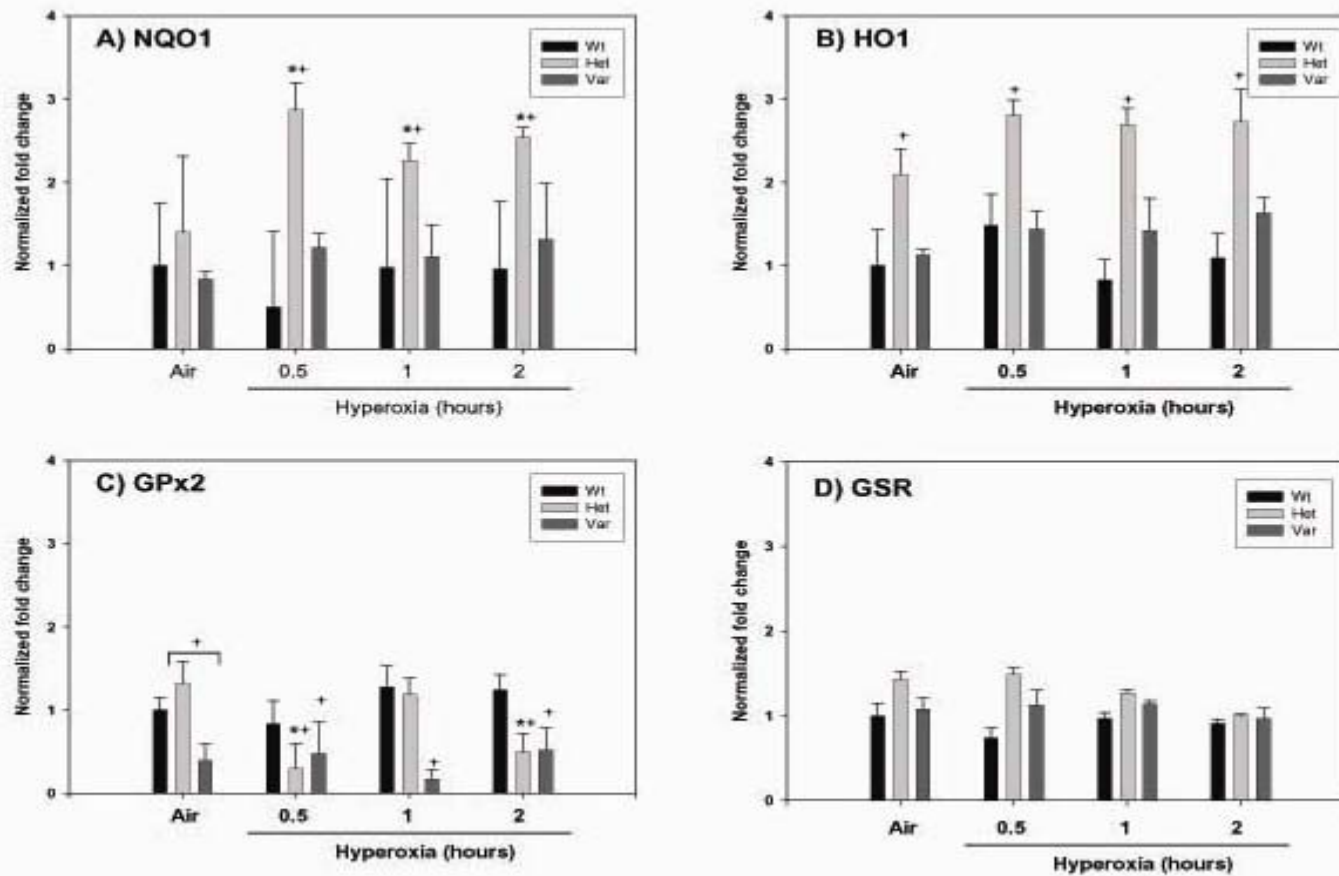

**Figure 4. mRNA expression of polymorphic *NRF2* -617 cells exposed to hyperoxia (95% O<sub>2</sub>) for 0, 0.5, 1 and 2 hours.** mRNA isolated from serum starved lymphoblasts was converted to cDNA and analyzed for *NQO1* (A), *HO1* (B), *GPx2* (C) and *GSR* (D) gene expression. Legend: Wt = wildtype CC; Het = heterozygote CA; Var = variant AA; \*, P < 0.05 compared with air; +, P < 0.05 compared with wildtype.

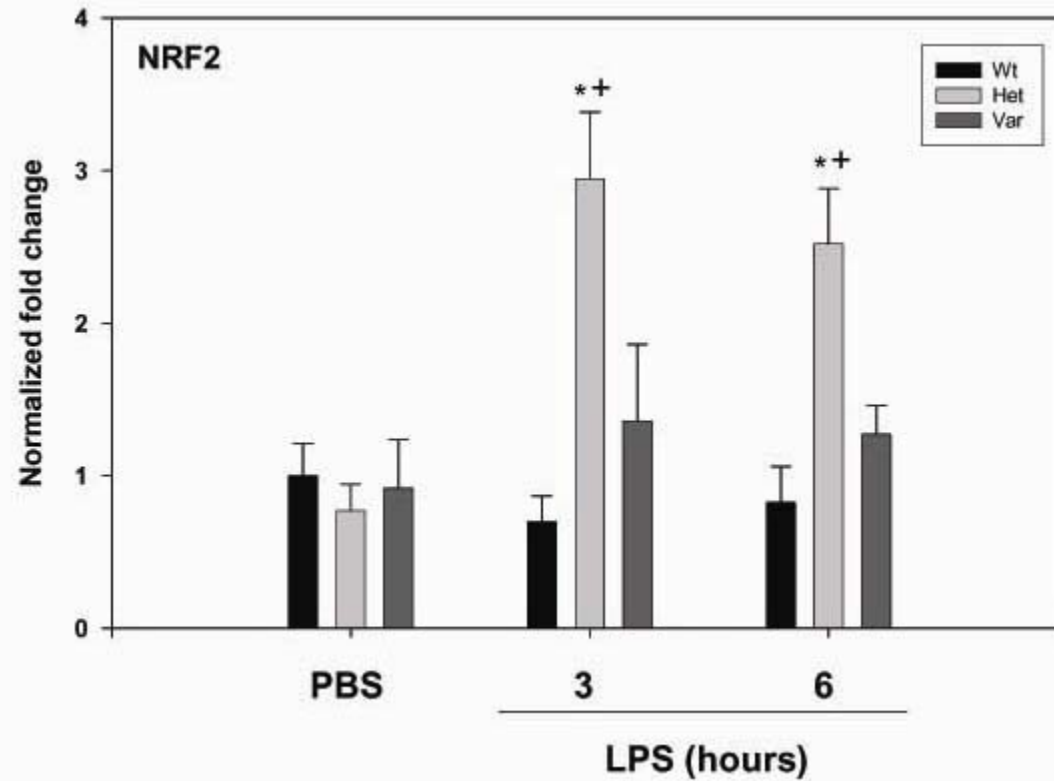

**Figure 5. mRNA expression of polymorphic *NRF2* -617 cells exposed to lipopolysaccharide (LPS) for 0, 3 and 6 hours.** mRNA isolated from serum complete lymphoblasts was converted to cDNA and analyzed for *NRF2* gene expression. Legend: Wt = wildtype CC; Het = heterozygote CA; Var = variant AA; \*,  $P < 0.05$  compared with PBS; +,  $P < 0.05$  compared with wildtype.

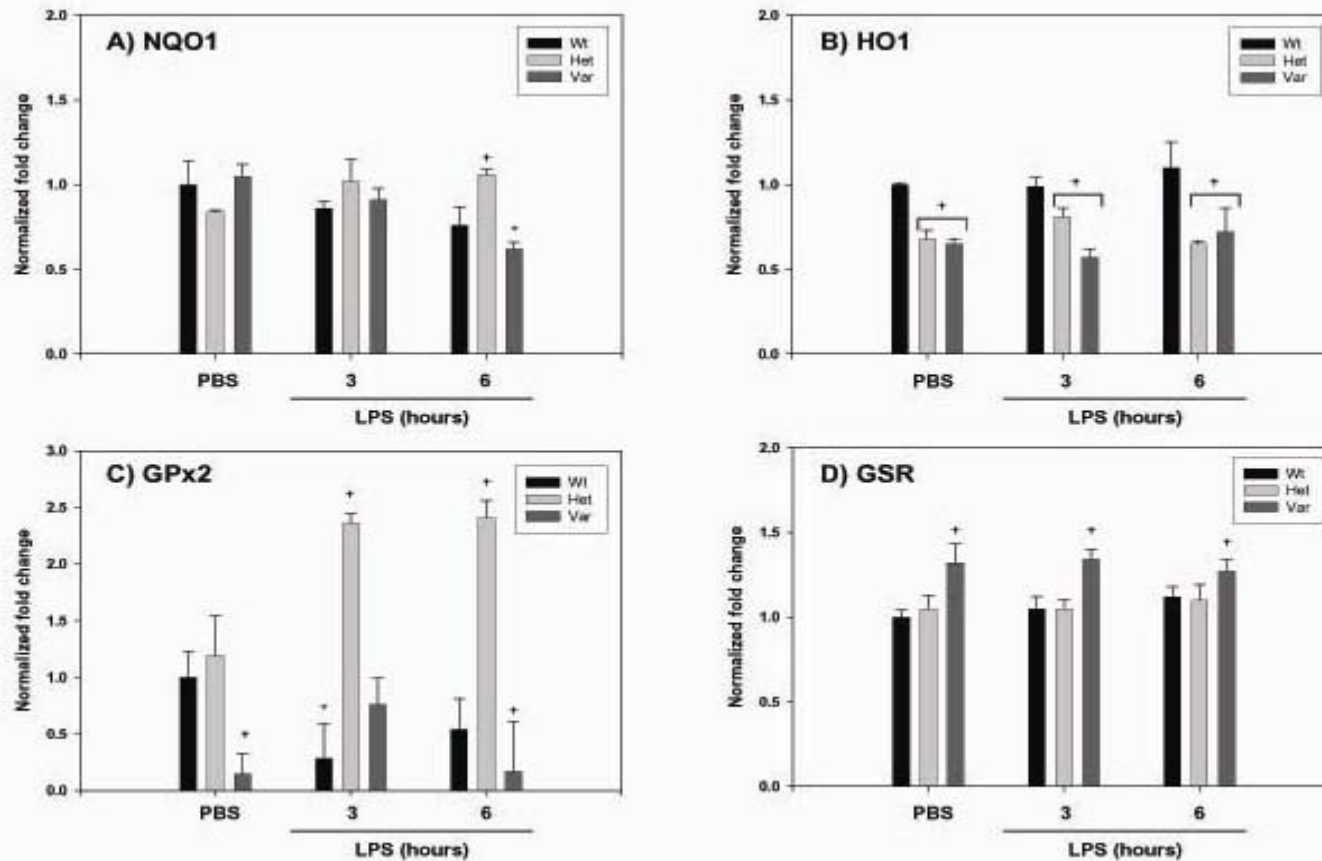

**Figure 6. mRNA expression of polymorphic *NRF2* -617 cells exposed to lipopolysaccharide (LPS) for 0, 3 and 6 hours.** mRNA isolated from serum complete lymphoblasts was converted to cDNA and analyzed for *NQO1* (A), *HO1* (B), *GPx2* (C) and *GSR* (D) gene expression. Legend: Wt = wildtype CC; Het = heterozygote CA; Var = variant AA; \*,  $P < 0.05$  compared with PBS; +,  $P < 0.05$  compared with wildtype.

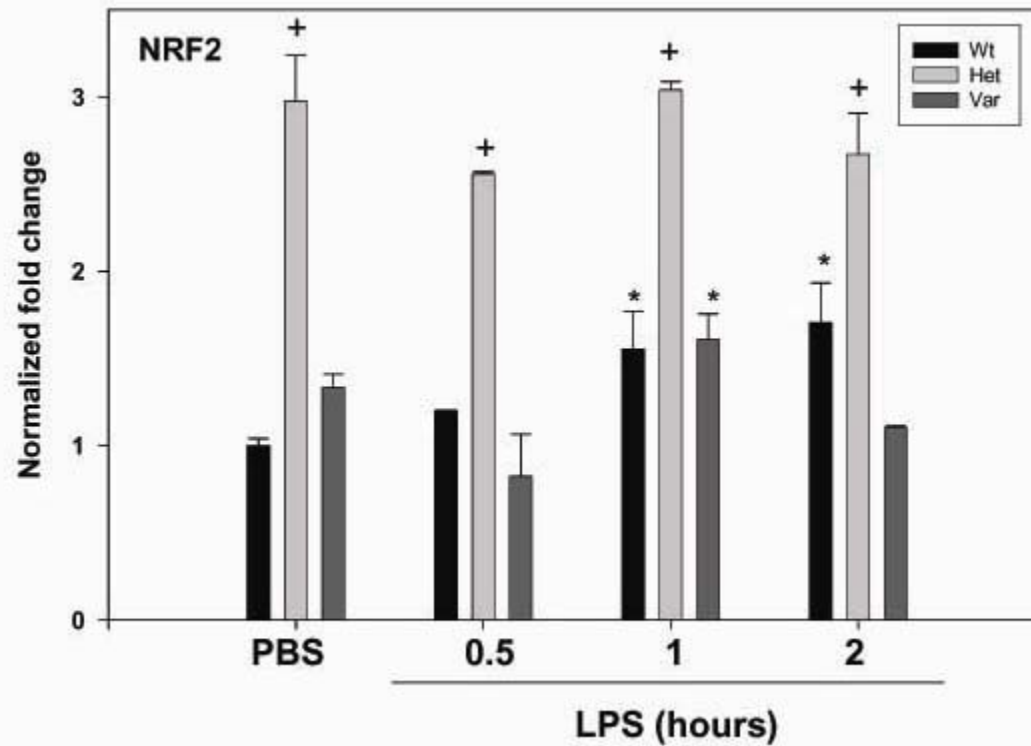

**Figure 7. mRNA expression of polymorphic *NRF2* -617 ARE cells exposed to lipopolysaccharide (LPS) for 0, 0.5, 1 and 2 hours.** mRNA isolated from serum starved lymphoblasts was converted to cDNA and analyzed for *NRF2* gene expression. Legend: Wt = wildtype CC; Het = heterozygote CA; Var = variant AA; \*, P <0.05 compared with PBS; +, P<0.05 compared with wildtype.

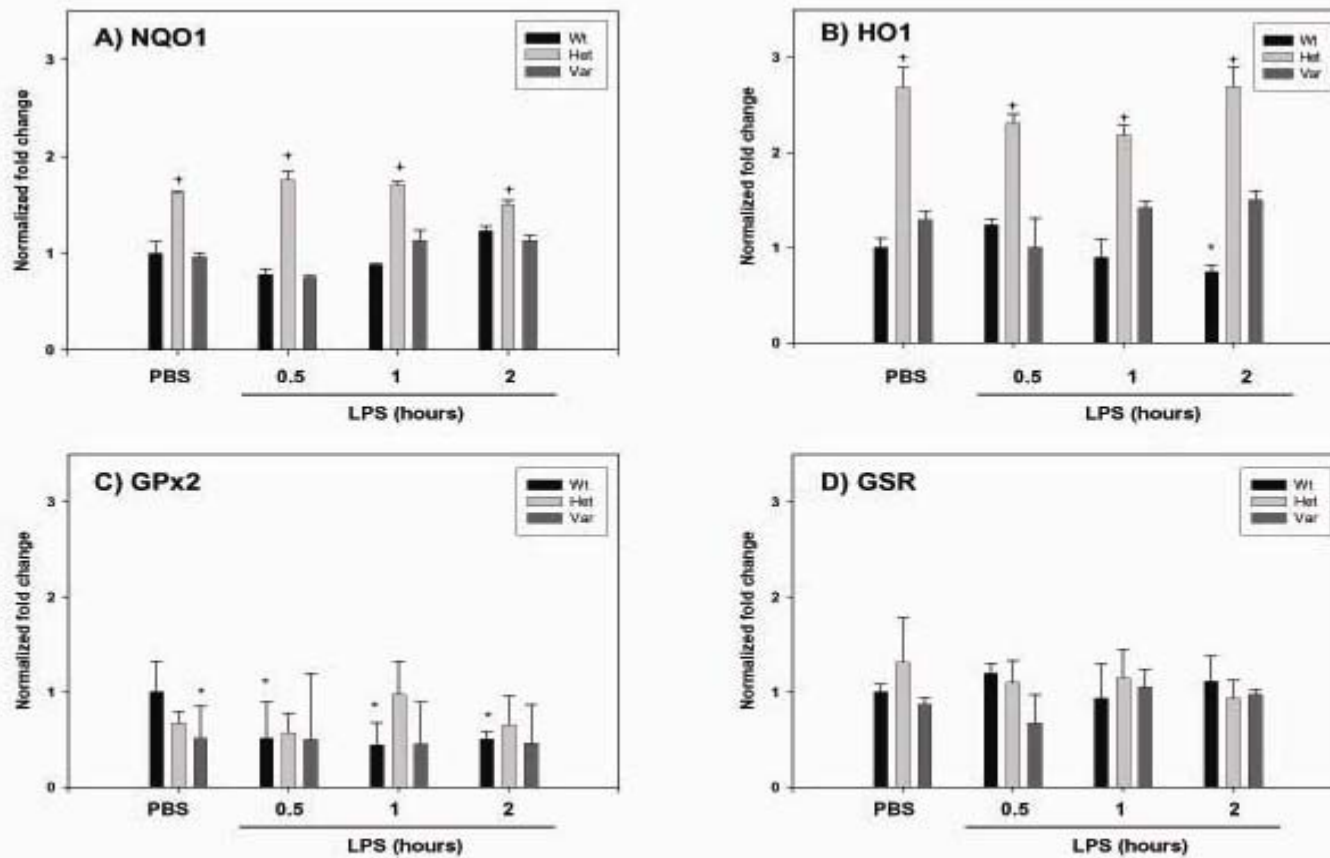

**Figure 8. mRNA expression of polymorphic *NRF2* -617 cells exposed to lipopolysaccharide (LPS) for 0, 0.5, 1 and 2 hours.** mRNA isolated from serum starved lymphoblasts was converted to cDNA and analyzed for *NQO1* (A), *HO1* (B), *GPx2* (C) and *GSR* (D) gene expression. Legend: Wt = wildtype CC; Het = heterozygote CA; Var = variant AA; \*,  $P < 0.05$  compared with PBS; +,  $P < 0.05$  compared with wildtype.

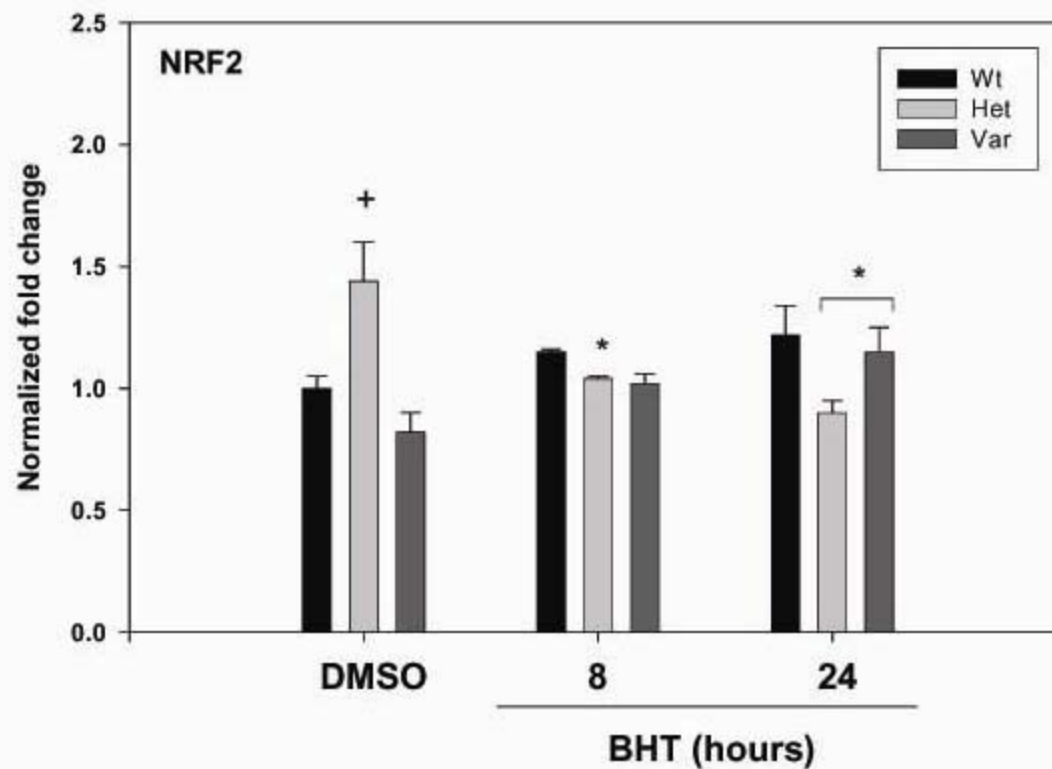

**Figure 9. mRNA expression of polymorphic *NRF2* -617 cells exposed to butylated hydroxytoluene (BHT) for 0, 8 and 24 hours.** mRNA isolated from serum complete lymphoblasts was converted to cDNA and analyzed for *NRF2* gene expression. Legend: Wt = wildtype CC; Het = heterozygote CA; Var = variant AA; \*, P <0.05 compared with DMSO; +, P<0.05 compared with wildtype.

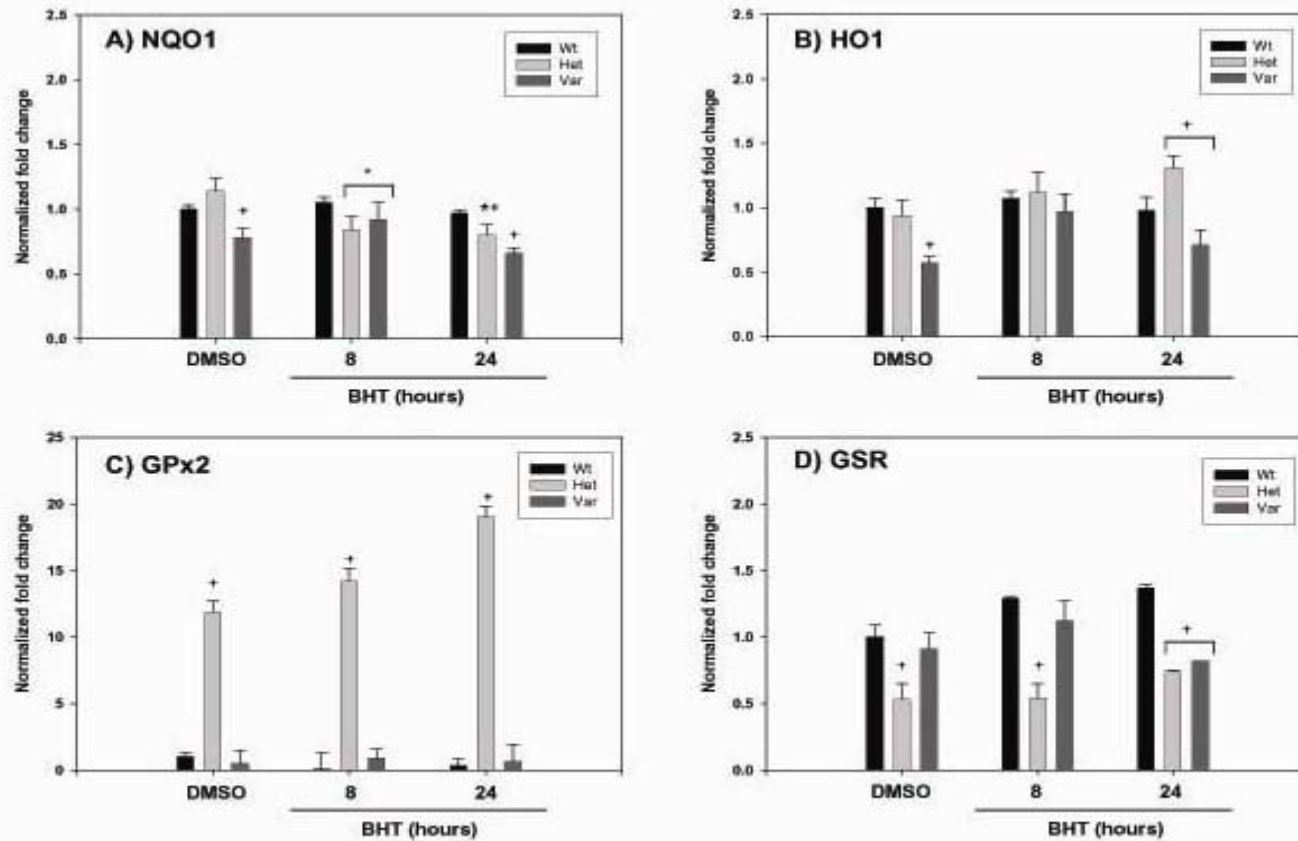

**Figure 10. mRNA expression of polymorphic *NRF2* -617 cells exposed to butylated hydroxytoluene (BHT) for 0, 8 and 24 hours.** mRNA isolated from serum complete lymphoblasts was converted to cDNA and analyzed for *NQO1* (A), *HO1* (B), *GPx2* (C) and *GSR* (D) gene expression. Legend: Wt = wildtype CC; Het = heterozygote CA; Var = variant AA; \*,  $P < 0.05$  compared with DMSO; +,  $P < 0.05$  compared with wildtype.

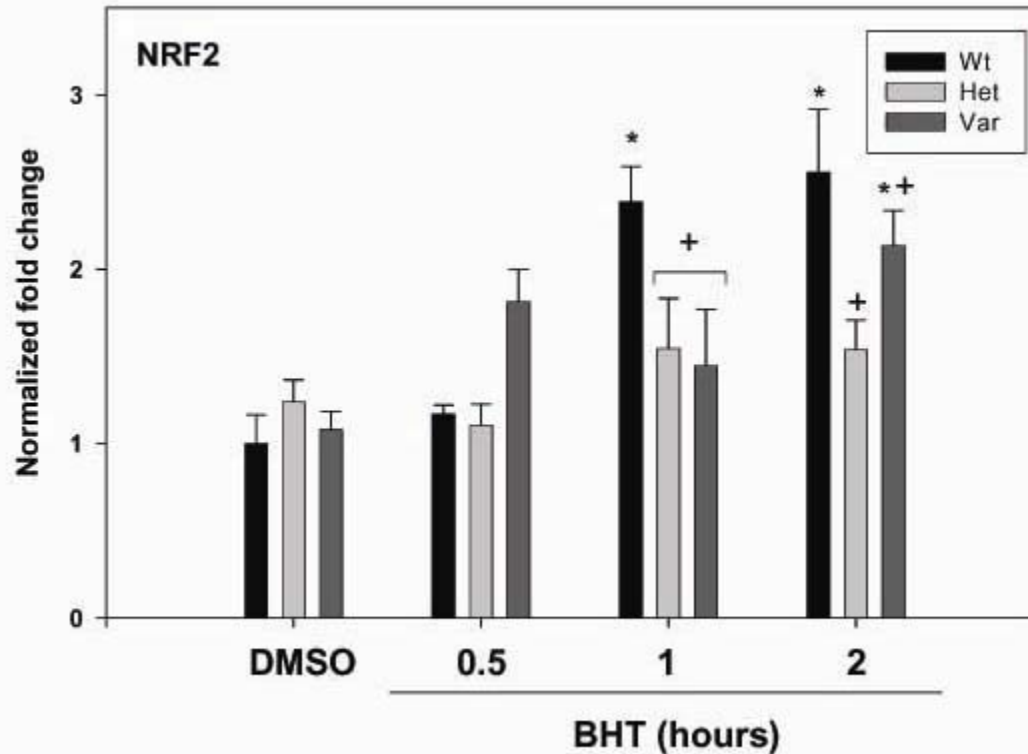

**Figure 11. mRNA expression of polymorphic *NRF2* -617 cells exposed to butylated hydroxytoluene (BHT) for 0, 0.5, 1 and 2 hours.** mRNA isolated from serum starved lymphoblasts was converted to cDNA and analyzed for *NRF2* gene expression. Legend: Wt = wildtype CC; Het = heterozygote CA; Var = variant AA; \*, P <0.05 compared with DMSO; +, P<0.05 compared with wildtype.

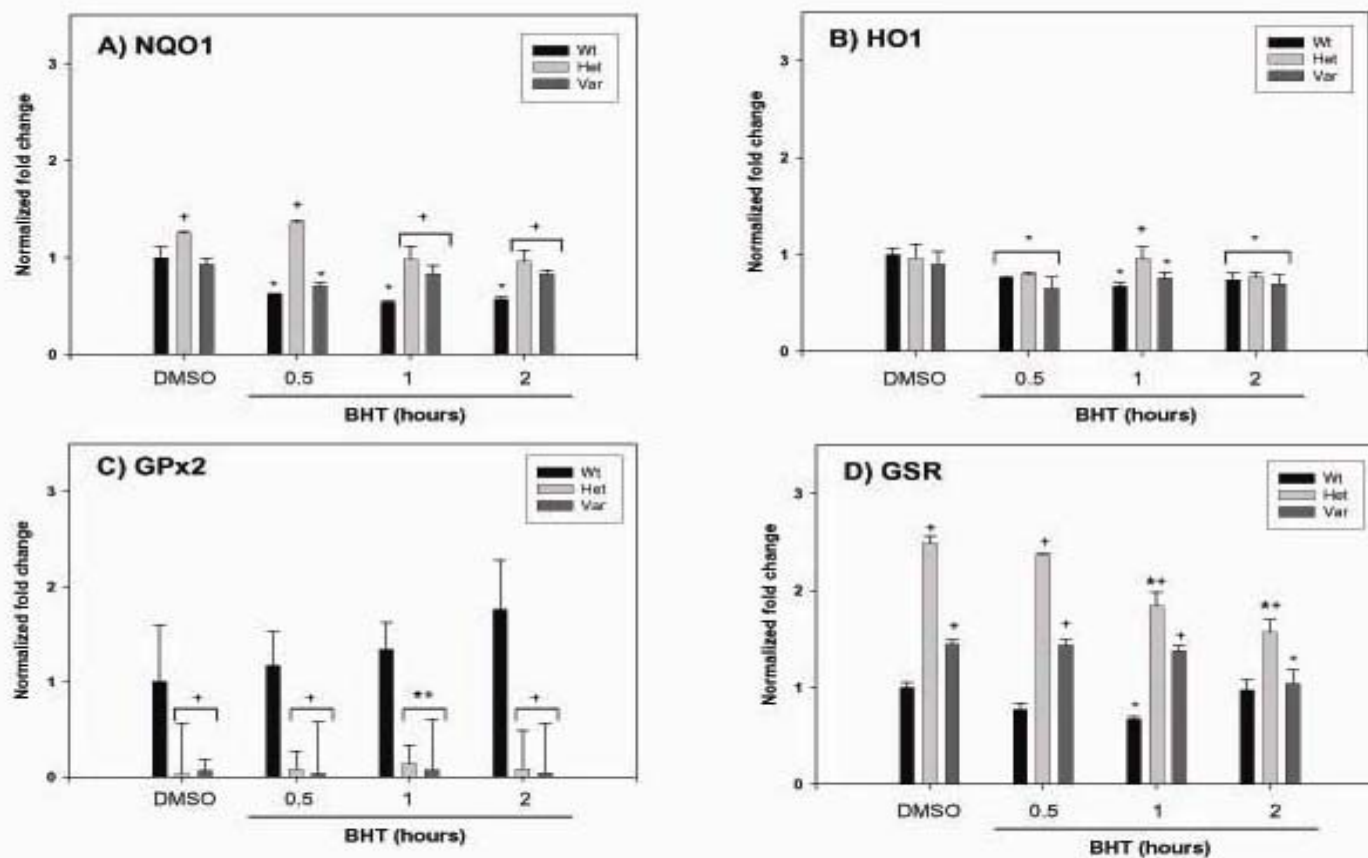

**Figure 12. mRNA expression of polymorphic *NRF2* -617 cells exposed to butylated hydroxytoluene (BHT) for 0, 0.5, 1 and 2 hours.** mRNA isolated from serum starved lymphoblasts was converted to cDNA and analyzed for *NQO1* (A), *HO1* (B), *GPx2* (C) and *GSR* (D) gene expression. Legend: Wt = wildtype CC; Het = heterozygote CA; Var = variant AA; \*, P < 0.05 compared with DMSO; +, P < 0.05 compared with wildtype.

## References

Banning, A., Deubel, S., Kluth, D., Zhou, Z., Brigelius-Flohe, R. (2005). "The GI-GPx gene is a target for Nrf2." Molecular and Cellular Biology **25**(12): 4914-4923.

Beckman, L., Frohlander, N. (1990). "Heterozygosity effects in studies of genetic markers and disease." Human Heredity **40**(6): 322-329.

Ben-Dor, A., Steiner, M., Gheber, L., Danilenko, M., Dubi, N., Linnewiel, K., Zick, A., Sharoni, Y., Levy, J. (2005). "Carotenoids activate the antioxidant response element transcription system." Molecular Cancer Therapeutics **4**(1): 177-186.

Chan, K., Kan, Y.W. (1999). "Nrf2 is essential for protection against acute pulmonary injury in mice." Proceedings of the National Academy of Sciences USA **96**(22): 12731-12736.

Cho, H.-Y., Jedlicka, A.E., Reddy, S.P., Kensler, T.W., Yamamoto, M., Zhang, L.Y., Kleeberger, S.R. (2002). "Role of NRF2 in protection against hyperoxia lung injury in mice." American Journal of Respiratory Cell and Molecular Biology **26**(2): 175-182.

Cho, H.-Y., Reddy, S.P., Debiase, A., Yamamoto, M., Kleeberger, S.R. (2005). "Gene expression profiling of NRF2-mediated protection against oxidative injury." Free Radical Biology & Medicine **38**(3): 325-343.

Gayle, D. A., Ling, Z., Tong, C., Landers, T., Lipton, J.W., Carvey, P.M. (2002). "Lipopolysaccharide (LPS)-induced dopamine cell loss in culture: roles of tumor necrosis factor-alpha, interleukin-1beta, and nitric oxide." Brain Research and Developmental Brain Research **133**(1): 27-35.

Itoh, K., Chiba, T., Takahashi, S., Ishii, T., Igarashi, K., Katoh, Y., Oyake, T., Hayashi, N., Satoh, K., Hatayama, I., Yamamoto, M., Nabeshima, Y. (1997). "An Nrf2/small Maf heterodimer mediates the induction of phase II detoxifying enzyme genes through antioxidant response elements." Biochemical and Biophysical Research Communications **236**: 313-322.

Kazzaz, J. A. (1999). "Hyperoxia in cell culture." Annals of the New York Academy of Sciences.

Kubaszek, A., Pihlajamaki, J., Komarovski, V., Lindi, V., Lindstrom, J., Eriksson, J., Valle, T.T., Hamalainen, H., Ilanne-Parikka, P., Keinanen-Kiukaanniemi, S., Tuomilehto, J., Uusitupa, M., Laasko, M. (2003). "Promoter polymorphisms of the TNF-alpha (G-308A) and IL-6 (C-174G) genes predict the conversion from impaired glucose tolerance to type 2 diabetes: the Finnish Diabetes Prevention Study." Diabetes **52**(7): 1872-1876.

Kwak, M. K., Itoh, K., Yamamoto, M., Kensler, T.W. (2002). "Enhanced expression of the transcription factor Nrf2 by cancer chemopreventive agents: role of the antioxidant response

element-like sequence in the nrf2 promoter." Molecular and Cellular Biology **22**(9): 2883-2892.

Li, N., Alam, J., Venkatesan, M.I., Eiguren-Fernandez, A., Schmitz, D., DiStefano, E., Slaughter, N., Killeen, E., Wang, X., Huang, A., Wang, M., Miguel, A.H., Cho, A., Sioutas, C., Nel, A.E. (2004). "Nrf2 is a key transcription factor that regulates antioxidant defense in macrophages and epithelial cells: protecting against the proinflammatory and oxidizing effects of diesel exhaust chemicals." Journal of Immunology **173**(5): 3467-3481.

Liby, K., Hock, T., Yore, M.M., Suh, N., Place, A.E., Risingsong, R., Williams, C.R., Royce, D.B., Honda, T., Honda, Y., Gribble, G.W., Hill-Kapturczak, N., Agarwal, A., Sporn, M.B. (2005). "The synthetic triterpenoids, CDDO and CDDO-Imidazolide, are potent inducers of heme-oxygenase I and Nrf2/ARE signaling." Cancer Research **65**(11): 4789-4798.

Martin, E. R., Lai, E.H., Gilbert, J.R., Rogala, A.R., Afshari, A.J., Riley, J., Finch, K.L., Stevens, J.F., Livak, K.J., Slotterbeck, B.D., Slifer, S.H., Warren, L.L., Conneally, P.M., Schmechel, D.E., Purvis, I., Pericak-Vance, M.A., Roses, A.D., Vance, J.M. (2000). "SNPping away at complex diseases: analysis of single-nucleotide polymorphisms around APOE in Alzheimer disease." American Journal of Human Genetics **67**(2): 383-394.

McDonagh, J. E., Dunn, A., Ollier, W.E.R., Walker, D.J. (1997). "Compound heterozygosity for the shared epitope and the risk and severity of rheumatoid arthritis in extended pedigrees." British Journal of Rheumatology **36**: 322-327.

Miller, D. T., Lee, R.Y., Suk Danik, J., Kozlowski, P., Chasman, D.I., Lazarus, R., Cook, N.R., Ridker, P.M., Kwiatkowski, D.J. (2005). "Association of common CRP gene variants with CRP levels and cardiovascular events." Annals of Human Genetics **69**: 623-638.

Motohashi, H., O'Connor, T., Katsuoka, F., Engel, J.D., Yamamoto, M. (2002). "Integration and diversity of the regulatory network composed of Maf and CNC families of transcription factors." Gene **294**: 1-12.

Nguyen, T., Huang, H.C., Pickett, C.B. (2000). "Transcriptional regulation of the antioxidant response element: Activation by Nrf2 and repression by MafK." Journal of Biological Chemistry **275**(20): 15466-15473.

Nguyen, T., Yang, C.S., Pickett, C.B. (2004). "The pathways and molecular mechanisms regulating Nrf2 activation in response to chemical stress." Free Radical Biology & Medicine **37**(4): 433-441.

Numazawa, S. (2004). "Nrf2 dependent gene expressions: A molecular toxicological aspect." Journal of Toxicological Science **29**(2): 81-89.

Owuor, E. D., Kong, A.N.T. (2002). "Antioxidants and oxidants regulated signal transduction pathways." Biochemical Pharmacology **64**: 765-770.

Pfaffl, M. W. (2004). Quantification strategies in real-time PCR. La Jolla, International University Line Press.

Wang, W., Jaiswal, A.K. (2006). "Nuclear factor Nrf2 and antioxidant response element regulate NRH:quinone oxidoreductase 2 (NQO2) gene expression and antioxidant induction." Free Radical Biology & Medicine **40**: 1119-1130.

Wang, X., Garrick, M.D., Yang, F., Dailey, L.A., Piantadosi, C.A., Ghio, A.J. (2005). "TNF, IFN-gamma, and endotoxin increase expression of DMT1 in bronchial epithelial cells." American Journal of Physiology Lung, Cellular and Molecular Physiology **289**(1): L24-L33.

Wild, A. C., Moinova, H.R., Mulcahy, R.T. (1999). "Regulation of gamma-glutamylcysteine synthetase regulatory subunit gene expression by the transcription factor Nrf2." Journal of Biological Chemistry **274**: 33627-33636.

## **Chapter 3**

### **Effects of the *NRF2* ARE polymorphism on antioxidant protein expression**

**Rationale:** Functional studies and mRNA expression analysis have shown significant differences in *NRF2* transcriptional activity associated with mutations to the ARE sequence. To further characterize the functional effects of ARE mutations, we assessed protein expression of NRF2, small Maf, and downstream antioxidants (NQO1, HO1, GPx2 and GSR) in wildtype and *NRF2* -617 polymorphic cell lines using an *in vitro* exposure system.

**Methods:** Lymphoblasts were maintained in serum complete media (10% FBS) or serum starved media (0.5% FBS) for 24 hours prior to exposure. The following day, serum complete cells were exposed to hyperoxia for 0, 4 and 8 hours, 100 µg/ml LPS for 0, 3 and 6 hours, or 25 µM BHT for 0, 8 and 24 hours. Serum starved cells were exposed to hyperoxia, 100 µg/ml LPS, or 25 µM BHT for 0, 0.5, 1 and 2 hours. Cells were harvested, spun down, collected on ice and washed twice with cold 1X PBS. Protein (nuclear and cytosolic fractions) was isolated, quantitated and aliquoted for western blot analysis. Nuclear fractions were probed for NRF2 and small Maf, whereas cytosolic fractions were probed for downstream antioxidants (NQO1, HO1, GPx2, and GSR). Blots were also probed for equal loading using lamin for nuclear fractions, and actin for the cytosolic component.

**Results:** Diminished NRF2 expression was observed in serum starved cells exposed to hyperoxia or LPS and significantly higher small Maf expression was seen in *NRF2* -617 variants. A similar pattern of expression was observed in serum complete cells exposed to LPS or BHT alone over a longer time period. Downstream antioxidant expression of HO1, GPx2 and GSR was markedly decreased in ARE variants following serum starvation and either hyperoxia or LPS exposure. GPx2 expression was substantially diminished in ARE variants after BHT treatment alone. ARE variant NQO1 expression was notably reduced by long term hyperoxia exposure or serum starvation coupled with BHT treatment.

**Conclusions:** The ratio of NRF2:Maf significantly affects downstream expression of antioxidant enzymes. Small Maf abundance (1:2 to 1:3 NRF2:Maf) results in decreased HO1, GPx2 or GSR expression, and ratios skewed toward NRF2 abundance (2:1 to 4:1 or higher NRF2:Maf) affect NQO1 expression. A delicate balance exists between NRF2 and Maf that regulates ARE-binding to activate antioxidants and may directly impact cellular defense against oxidative stress.

## **Introduction**

Site specific interactions between transcription factors and DNA binding elements provide targeted signal transduction pathways that relay information from the cell periphery to the nucleus. Specificity of transcriptional regulation is of utmost importance, and elaborate systems of regulation exist to control accuracy. Post-translational modifications affect virtually all parts of transcription factor function and act as sensors of upstream signaling events to modulate function. A diverse array of covalent modifications occur that dynamically and reversibly influence protein-protein and protein-DNA interactions, as well as subcellular localization, activity and stability. Targeted residues may be removed proteolytically by sumoylation or ubiquitination, modified by acetylation, or side chains altered by glycosylation and/or phosphorylation.

Phosphorylation by kinases occurs primarily in the cytoplasm, and modulates activity of a variety of cellular proteins, including the transcription factor NRF2. Protein modification by phosphorylation at Ser40 is believed to play a key role in regulating NRF2 stability. Under oxidative stress conditions, NRF2 is phosphorylated at Ser40 by activated aPKC or other protein kinases, weakening inhibition by KEAP1 and leading to NRF2 stabilization (Bloom 2003). NRF2 stabilization decreases its rate of proteasomal degradation, and is sufficient to trigger its nuclear translocation. Stability of many intracellular transcription factors is determined by their rate of turnover or degradation by the proteasome as shown in studies of NFkB and c-Fos (Numazawa 2004). Compelling evidence suggests that NRF2 protein stabilization constitutes a major regulatory mechanism mediating activation of many ARE-dependent genes (Ngugen 2004).

Oxidative stress conditions enhance instead of limit overall activity of the ubiquitin proteasome which is required to remove damaged proteins from cells. ARE inducers act not as proteasome inhibitors, but as distinct pathways to stabilize Nrf2 and decrease its rate of degradation (Ngugen 2004). This may be brought about by mechanisms to weaken the interaction between Nrf2 and E3 ligase. A dose-dependent increase in ARE-mediated reporter gene activity was observed in cells transfected with increasing amounts of Nrf2-expressing vector without the need for treatment with an ARE-inducer (Ngugen 2004). Thus Nrf2 could translocate into the nucleus to activate gene transcription in a non-regulated manner and stabilization alone triggered nuclear localization.

In work with keratinocytes exposed to oxidative stress, Nguyen *et al* (2004) found that *t*BHQ induced an overall increase in cellular levels of Nrf2 without affecting its apparent rate of transcription. Furthermore, the posttranscriptional response was not unique to *t*BHQ, and was also observed in cells treated with sulforaphane, cadmium and DEM, all potent ARE inducers. This suggests an underlying regulatory mechanism to increase Nrf2 stability and evidence of a post-translational mechanism to increase protein levels. Papaiahgari *et al* (2004) found evidence of Nrf2 nuclear accumulation without an apparent increase in transcript levels following 30 to 60 minutes of exposure to hyperoxia. This provides additional evidence that protein stability is essential for major regulatory mechanisms mediating Nrf2 activation by inducers of ARE-dependent genes. NRF2 activation could be influenced by post-translational modifications that directly affect its DNA binding affinity, transactivation capability, or interactions with additional transcription factors and/or the basal transcription apparatus.

Nrf2 cannot bind the ARE as a homodimer, and must heterodimerize with small Maf proteins to bind the ARE of downstream antioxidants, forming a powerful transactivating complex (Katsuoka 2005). Of the CNC bZIP family members, Nrf2 is one of the most potent transcriptional activators, activating reporter gene transcription nearly 10-fold more than Nrf1 or Nrf3 (Kato 2001). Such strong activation potential is attributed to the synergistic interaction between the coactivator CBP/p300 and the Neh4 and Neh5 transactivation domains of Nrf2. The requirement of a GC element in the ARE consensus sequence allows optimal interaction with small Maf proteins, which serve as co-effectors of the oxidative stress response (Katsuoka 2005). Conserved tyrosine and glycine residues facilitate a conformational change in the basic domain of Maf proteins, allowing recognition and interaction with the flanking GC sequence of the MARE. An additional three residues in the extended homology region (Val, Asp, and Arg) enhance binding specificity to the MARE (Motohashi 2002).

Because multiple bZIP transcription factors can interact with Maf proteins to bind the MARE or ARE, a large degree of transcriptional complexity can occur. Of the many CNC binding partners available, the Bach and Fos proteins have been suggested to antagonize Nrf2 leading to repression of ARE-dependent transcription (Motohashi 2002). Deficiency of small Maf impairs the function of CNC and Bach proteins, suggesting the quantitative balance

between these factors serves as a molecular switch to enhance or repress transcription. Small Maf act as repressors by competing with transcription factors for the MARE and by sequestering gene loci within heterochromatin (Katsuoka 2005). In conjunction with specific CNC partners such as NRF2, small Maf can also act as potent co-activators of transcription. Variation in subcellular localization could represent an important means for direct regulation by small Maf and CNC proteins. Overabundance of small Maf can also cause repression, and even a two-fold excess converted *nrf2* transcriptional activity from maximal to suppressed levels (Motohashi 2002). Varied requirements for small Maf may be attributed to variations in the ARE and flanking sequence of each gene which results in differential affinity for the activator Nrf2-Maf complex. Abundance of small Mafs has been reported to fluctuate in response to oxidative stress (Katsuoka 2005), and small Maf proteins may generate diversity in Nrf2-mediated gene regulation by altering their proportions.

In addition to the principal role of the Nrf2:Maf heterodimer in ARE activation, recent studies have shown that higher order transcriptional co-activators are also involved in ARE regulation. Microinjection studies by Zhu *et al* (2001) indicated a hierarchy of transcriptional regulation, beginning with direct ARE-specific interaction between the Nrf2:Maf complex and the consensus sequence, followed by interactions with secondary and tertiary co-activators. GFP expression was significantly diminished by microinjected antibodies individually directed against Nrf2, MafK, p300 and CBP, suggesting the involvement of all four factors in transcriptional regulation of the ARE (Zhu 2001). Proposed secondary co-activators include ARE-binding protein-1 (ARE-BP-1), an ARE specific p160 family member known to interact with CBP/p300. CBP and p300 proteins are essential tertiary co-activators for efficient gene induction in studies of transcription factors including NFkB, AP-1, and nuclear receptors (Kwok 1994; Kamei 1996; Zhang 1996; Gerritsen 1997). CBP/p300 proteins nucleate around the transcription factor complex, remodeling chromatin to an open conformation and directly interacting with the basal transcription apparatus to augment transactivation of gene targets.

Different AREs have different sequence requirements. The sequence of the response element could manipulate orientation of the activating transcription complex, influencing interaction with other co-factors. Specific ARE sequences may represent suboptimal binding sites to prevent transcription from being dominated by the Nrf2-Maf complex. It is likely

that binding of Nrf2 to an ARE sequence enhances association of RNA Pol II with the core promoter through either direct interaction with the transcriptional machinery or via CBP/p300. In this manner, activation of downstream gene targets can be regulated on multiple levels, through primary association of the NRF2:Maf complex to the ARE, and through interactions with secondary co-activators and tertiary elements of the transcription machinery. Hierarchical regulation provides numerous checkpoints whereby antioxidant activity in the cell can be downregulated and return to homeostasis once the oxidative insult has passed.

We have previously shown that an *NRF2* ARE promoter mutation at -617 affected functional activity using luciferase and gel shift assays. We have also shown that serum starved *NRF2* heterozygotes exposed to hyperoxia or LPS exhibited strong basal and inducible activity of *NRF2*, as well as several downstream antioxidants (*NQO1*, *HO1*). A similar pattern of *NRF2* and *GPx2* induction was observed in serum-starved *NRF2* heterozygotes. *GPx2* was differentially expressed between cell lines during BHT exposure independent of *NRF2* upregulation. The current study was designed to analyze NRF2 and small Maf protein levels in response to oxidative exposures (hyperoxia, LPS and BHT) and to determine effects of the NRF2:small Maf activating complex on downstream protein expression of NQO1, HO1, GPx2 and GSR.

## **Materials and Methods**

### ***In vitro techniques and oxidative stress exposures***

Lymphoblast cell lines were purchased from the Coriell Repository (Camden NJ) and maintained at 37°C in RPMI media (Gibco BRL, Carlsbad CA) supplemented with 10% (v/v) heat-inactivated fetal bovine serum and 1% penicillin-streptomycin (Sigma, St. Louis MO). Cells were grown to 70-80% confluence in 75 cm<sup>2</sup> flasks prior to exposure to 95% oxygen [0, 4, and 8 hours] (National Welders, Charlotte NC), 100 µg/ml LPS [0, 3, and 6 hours] (Sigma, St. Louis MO), or 25 µM BHT [0, 8, and 24 hours] (Sigma, St. Louis MO). Quiescent cells were maintained at 37°C in RPMI media supplemented with 0.5% (v/v) heat-inactivated fetal bovine serum and 1% penicillin-streptomycin (Sigma, St. Louis MO) for 24 hours prior to exposure. The following day cells grown in 75 cm<sup>2</sup> flasks were exposed to either 95% oxygen, 100 µg/ml LPS, or 25 µM BHT for 0, 0.5, 1, and 2 hours.

### ***Sequence verification of antioxidant AREs***

Cells were collected on ice and spun down in microcentrifuge tubes at 10,000 x g for 5 minutes prior to DNA extraction using the Genra Puregene DNA purification system (Genra Systems, Minneapolis MN). A Beckman Coulter D640 spectrophotometer was used to determine DNA purity and concentration. DNA was sequenced using primers (Sigma Genosys, The Woodlands TX) spanning the ARE region of each gene and about 100-200 bp flanking sequence (Table 5). 100 ng of genomic DNA was amplified using the Epicentre Failsafe system (Madison WI), products purified using the GenElute PCR cleanup kit (Sigma, St. Louis MO) and sequencing reactions performed using the DYEnamic ET terminator kit (Amersham Biosciences, Piscataway NJ). Purified products were run on an ABI 377 Automated DNA Sequencer (Applied Biosystems, Foster City CA) and data aligned with published sequences using Vector NTI (Invitrogen, Carlsbad CA).

### ***Protein isolation and characterization***

Cells were collected on ice and spun down in microcentrifuge tubes at 4000 x g for 4 minutes. Pellets were washed twice with cold 1X PBS and placed into hypotonic buffer with protein inhibitors (Active Motif, Carlsbad CA). Protein was isolated from lymphoblasts using the Transfactor kit (BD Biosciences, San Jose CA). Cytosolic and nuclear fractions were measured using the DC assay (BioRad, Hercules CA), with BSA as a standard. Standard curves were linear ( $r^2 \geq 0.95$ ) up to 7.35  $\mu\text{g/ml}$  of BSA, with coefficients of variation between replicates of the same sample less than 10%.

### ***Western blot analysis***

For cytosolic fractions 30  $\mu\text{g}$  of protein from each cell line and exposure was loaded onto a 10-20% Tris-HCl Criterion gel (BioRad, Hercules CA). For nuclear fractions 20  $\mu\text{g}$  of protein from each cell line and exposure was loaded onto a 4-20% Tris-HCl Criterion gel and run as outlined below. Proteins were separated in running buffer at constant current (150 mV) for one hour. Separated proteins were transferred to nitrocellulose membranes for 1 hour at 100V using transfer buffer (25 mM tris, 192 mM glycine, 15% methanol, 0.1% SDS). Membranes were blocked for 1 hour in 5% nonfat milk in TBST (TBS, 0.05% Tween-20) with continuous shaking and incubated overnight in primary antibody at 4°C (see Table 6 for dilutions). Primary antibody was removed by washing three times for 10 minutes each in TBST followed by treatment with secondary antibody and continuous shaking. Secondary

antibody was removed using three washes with TBST and continuous shaking for 10 minutes/wash prior to detection. Blots were developed using the Pierce SuperSignal West Pico Chemiluminescent substrate system (Pierce, Rockford IL) with horseradish peroxidase for antibody detection followed by exposure to BioMax MR film (Kodak, Rochester NY). Bands were compared to a kaleidoscope Precision Plus standard (BioRad, Hercules CA) to determine protein molecular weight, and densitometry quantitated using the GelDoc system from BioRad.

### ***Statistical analysis***

Internal housekeeping proteins lamin (nuclear fractions) and actin (cytosolic fractions) were quantitated to account for differences in loading. Data from all experiments were analyzed by normalization to basal expression levels of wildtype air or vehicle alone. Differences between groups were tested by two-way analysis of variance (ANOVA) followed by Student-Newman-Keuls (SNK) *a posteriori* comparison of means (Sigma Stat, Jandel Scientific Software, San Rafael CA). Data sets that were not normally distributed were tested non-parametrically using Kruskal-Wallis one-way ANOVA on ranks. A two-sided p-value of less than 0.05 was considered statistically significant.

### **Results and Discussion**

DNA extracted from each cell line was sequence verified to confirm *NRF2* mutations as well as the consensus sequence of downstream ARE gene targets. Genotypes at the *NRF2* -617 locus were confirmed as wildtype (CC), heterozygote (CA) and variant (AA) as screened previously. Sequence results for *NQO1*, *HO1*, *GPx2* and *GSR* did not differ from ARE consensus sequences published in GenBank, and no allelic variation in downstream antioxidant AREs was noted among genotyped *NRF2* cell lines.

### ***Hyperoxia***

Expression levels of *NRF2*, *HO1*, *GPx2*, and *GSR* were not significantly different between *NRF2* genotypes after hyperoxia exposure to serum complete cells (Figure 1). Small Maf expression was reduced in variants basally and was further diminished (0.3-fold) after hyperoxia exposure (Figure 1). Similar reductions in small Maf activity were noted for *NRF2* heterozygotes after 8 hours of treatment. *NQO1* expression in wildtype cells was not

significantly induced by hyperoxia; however, NQO1 induction was observed in *NRF2* heterozygote and variant cells following exposure (Figure 1).

In contrast to the 1:1 proportion of NRF2:Maf in wildtype cells, ratios of the activating complex in hyperoxia-exposed ARE variant cells begin at 2:1, and in heterozygotes, ratios peak at 4:1 after 8 hours of exposure (Table 7). The disproportionate skew toward NRF2 abundance and diminished Maf protein results in reduced downstream NQO1 expression in comparison to wildtype cells. Remaining antioxidants were not as affected by the NRF2:Maf ratio but showed slightly lower levels of HO1 and GSR expression after 8 hours hyperoxia exposure. NQO1 contains a single ARE for optimal inducible activity, and was most affected by the NRF2:Maf ratio which may alter binding to the NQO1 ARE site for activation. Antioxidants such as HO1 contain multiple ARE sites and can compensate for poor NRF2:Maf binding by partial activation of both AREs. Wildtype cells were largely unaffected by hyperoxia exposure and inducible protein expression did not vary from basal levels.

Significantly lower NRF2 expression was observed in serum-starved *NRF2* variants basally and following exposure (Figure 2). In contrast, small Maf expression was significantly increased in *NRF2* variants after hyperoxia exposure, and was markedly downregulated (0.5-fold) in heterozygotes after exposure (Figure 2). NQO1 was induced in variants within 30 minutes (2-fold), however *NRF2* heterozygotes showed no response to hyperoxia (Figure 2). A reduction in HO1 expression was observed for all cell lines following hyperoxia exposure (Figure 2). No significant changes in GPx2 or GSR were observed (Figure 2).

Decrements in NRF2 expression occurred within 30 minutes of hyperoxia treatment, and antioxidant expression was changed after exposure. As Papaiahgari *et al* (2004) showed in C10 and A549 cells, NRF2 translocates from the cytoplasm to the nucleus within 30 to 60 minutes of hyperoxia exposure. It is likely that NRF2 translocation occurs within a similar time frame in lymphoblast cells, and the concomitant decrease in small Maf levels is a result of its nuclear localization to form the NRF2:Maf complex. *NRF2* heterozygotes had low Maf expression after hyperoxia exposure, suggesting heterozygosity may impact recruitment and localization of small Maf under these exposure conditions. Induction of antioxidants occurs after the NRF2:Maf complex recognizes and binds the ARE.

Antioxidants were most affected by hyperoxic insult in the serum-starved *NRF2* variant cells at specific exposure times, and showed significant reductions in HO1, GPx2 and GSR expression, and interestingly, a marked increase in NQO1 activity. The increased expression of NQO1 in variant cells may again be related to the composition of the NRF2:Maf activating complex. *NRF2* variants had lower NRF2 in comparison to high levels of small Maf protein, suggesting this ratio (1:2 NRF2:Maf) enhanced NQO1 activity under our exposure conditions, but for other antioxidants, repressed activity. NQO1 has reduced inducible activity compared to multiple ARE containing proteins such as HO1, and may be more susceptible to diminished capacity of the NRF2:Maf transactivating complex. Like many ARE-bearing genes, however, it does contain an embedded TRE sequence allowing for differential regulation by transcription factors. Should activation by NRF2 become impaired, activation by AP1 could compensate.

HO1 expression was reduced in all cell lines within 1 hour of exposure, and was not induced upon hyperoxia exposure. HO1 expression is based on the intricate balance of activation by NRF2 and repression by BACH proteins at the ARE, and its reduced activity could be a result of other factors that were not tested in this study. BACH proteins could compete with NRF2:Maf complex formation to repress HO1 activation under these exposure conditions. Variants with diminished capacity for activation of critical antioxidants are prone to oxidative injury following hyperoxia exposure. It is possible that NRF2 levels present in the cell were transiently lower and were not detected during this time course. Although NRF2 and downstream antioxidant expression levels do not follow the same pattern, variants at the NRF2 ARE locus clearly affect expression of NQO1, HO1, GPx2 and GSR following hyperoxia exposure.

### ***Lipopolysaccharide***

Expression levels of NRF2, HO1, and GPx2 were not significantly different between *NRF2* genotypes after LPS exposure (Figure 3). Small Maf expression was significantly reduced in *NRF2* heterozygotes basally and after 3 hours of exposure, and remained low throughout treatment (Figure 3). HO1 and GSR were significantly induced in all *NRF2* genotypes after LPS treatment for 6 hours (Figure 3). As seen for small Maf activity, lower levels of HO1 induction were evident in *NRF2* heterozygotes as compared to wildtype and

variant cells. Ratios of NRF2 to Maf remained roughly equivalent throughout the time course for all except the 6 hour time point where variant cells had a 1:3 (NRF2:Maf) ratio (Table 7). Of the antioxidants studied, only GPx2 activity was adversely affected by the activating complex ratio, with downregulation evident in *NRF2* variants following exposure.

As shown in human monocytic cells, Nrf2 translocated to the nucleus in response to LPS and bound an ARE site in the human HO1 promoter with peak induction seen at 8 hours (Rushworth 2005). Comparable strong HO1 induction was seen in lymphoblasts exposed to 6 hours of LPS for all *NRF2* genotypes. Small Maf and HO1 expression patterns were similar, suggesting that HO1 activation is dependent on recruitment of Maf protein to the NRF2:Maf complex. Alternatively, a different CNC binding partner may bind Maf to activate HO1. Parallel low level increases in HO1 and small Maf expression in *NRF2* heterozygote cells indicate a decreased propensity for antioxidant activation, which was evident in low level HO1 expression after 3 hours of LPS exposure (Figure 3). At this time point reduced HO1 activity may be due to the availability of Maf protein to form the NRF2:Maf complex as opposed to levels of NRF2 alone.

Serum starved cells exposed to short term LPS exhibited a similar pattern of NRF2 expression after exposure. Levels were significantly lower in *NRF2* variant cells basally and throughout treatment, with only minimal NRF2 induction seen at 30 minutes (Figure 4). In contrast, *NRF2* heterozygote expression was almost 3-fold higher basally and was induced up to 4-fold within 30 minutes of LPS exposure. Wildtype cells exhibit a 2.5-fold increase in NRF2 expression within 30 minutes and increase up to 3.5-fold by 2 hours. Small Maf expression was significantly repressed in *NRF2* heterozygotes basally and up to 1 hour after treatment, while variant cells had significantly higher basal activity and were downregulated after exposure (Figure 4).

NQO1 activity was significantly induced by LPS treatment in all three *NRF2* genotypes (Figure 4). Of the antioxidants studied, HO1 expression was the most varied, with lowest levels of activity seen at 1 hour of LPS for wildtype and variant cells compared to a 2.4-fold induction in heterozygote cells at the same time point (Figure 4). After 2 hours, HO1 activity was reduced in all cells below baseline. In contrast, after 2 hours of LPS, GPx2 expression was markedly reduced in *NRF2* variant cells in comparison to wildtype and

heterozygote cells. GSR expression was significantly reduced in *NRF2* heterozygotes and variants at 1 and 2 hours of exposure (Figure 4).

Ratios of NRF2:Maf did not vary significantly from 1:1 in LPS-exposed serum complete cells, resulting in roughly equivalent antioxidant expression profiles of NQO1, GSR and GPx2 for all *NRF2* genotypes (Table 7). In contrast, ratios of the activating NRF2:Maf complex in the serum-starved LPS-exposed cells were dramatically different between cell lines. Wildtype and heterozygote cells had ratios skewed toward NRF2 abundance (up to 10:1) which did not significantly affect downstream antioxidant expression (Table 7). ARE variants, on the other hand, exhibited ratios skewed toward Maf protein (up to 1:5) and as seen in *nrf2* transcriptional repression studies by Motohashi *et al* (2002), even a two-fold excess of small Maf reduced transcriptional activity of *NRF2* in polymorphic *NRF2* lymphoblasts. *NRF2* variants had increased Maf abundance and suppressed NRF2 expression, resulting in repression of GPx2 and GSR activity. After 2 hours of LPS, GPx2 activity was markedly reduced in *NRF2* variant cells and GSR expression was reduced in variants and heterozygotes, which suggests decreased NRF2 activation potential for ARE sequence variants at later points.

### ***Butylated hydroxytoluene***

Serum complete cells treated with BHT showed lower basal NRF2 expression in *NRF2* variant cells (60% reduction compared to wildtype DMSO) and an 80% decrease in *NRF2* heterozygotes after 24 hours (Figure 5). No significant differences in small Maf or NQO1 expression were observed among *NRF2* genotypes following BHT exposure (Figure 5). HO1 was significantly increased in response to 24 hours of BHT treatment in *NRF2* wildtype and heterozygote cells (Figure 5). GPx2 expression was markedly lower in wildtype cells basally and was strongly induced (3-fold) within 8 hours, whereas expression was 2.5-fold higher in *NRF2* variant cells at baseline and decreased to basal wildtype levels within 8 hours of treatment (Figure 5). In contrast, high basal GPx2 expression was observed in heterozygote cells (almost 3-fold) and activity declined after 8 hours. GSR expression was downregulated with BHT treatment, and did not differ between *NRF2* genotypes (Figure 5).

No significant differences in NRF2 expression were observed in serum starved BHT-exposed cells, however variant cells had higher levels of small Maf expression after only 30 minutes of BHT (Figure 6). NQO1 expression was significantly downregulated in *NRF2* variant (80% reduction) and heterozygote cells (60% reduction) after 2 hours of BHT (Figure 6). Induction of HO1 occurred within 30 minutes of treatment, and highest levels were seen at 2 hours, however, expression did not vary significantly between *NRF2* genotypes (Figure 6). GSR expression was also strongly induced with BHT exposure, and highest activity was seen in wildtype cells after 1 hour of treatment (Figure 6). GPx2 expression did not significantly change after exposure.

The NRF2:Maf ratio did not vary significantly from 1:1 throughout BHT exposure to serum starved cells, and was not skewed as shown in hyperoxia and LPS exposures (Table 7). Of the antioxidants studied, only NQO1 showed any significant effect of the *NRF2* ARE mutation, with lowest expression seen in *NRF2* variant cells after 2 hours of BHT. Modest reductions in HO1 and GPx2 were also noted after 2 hours BHT in variant cells but are unlikely to affect cellular defense mechanisms. Interestingly inducible expression of downstream enzymes peaked at 30 minutes in *NRF2* variants, and no further induction was seen during exposure. Similarly, in the serum complete cells exposed to BHT for 24 hours, antioxidants were downregulated and did not show induction in response to BHT. Without sustained activation of detoxifying enzymes, *NRF2* ARE variants may be more susceptible to the cytotoxic effects of ROS produced during oxidative stress.

## Summary

Regulation of NRF2 for nuclear translocation is dependent on protein turnover and stabilization. In epithelial cells (A549 and C10), oxidative stress conditions recruit NRF2 within 30 minutes to activate ARE-bearing antioxidants without a corresponding increase in transcript levels (Papaiahgari 2004). Our data also indicate antioxidant activation within 30 minutes of oxidative treatment, with the strongest antioxidant activity noted after exposure to LPS and BHT. We noticed a heterozygosity effect at the transcript level that was not seen in our western blot analysis; however we did observe good correlation between mRNA and protein data.

Limitations of our protein study include selection of cell type and oxidative agent, dose and length of exposure, as well as insufficient replicates for protein analysis. Protein isolated from exposed lymphoblasts was further separated into nuclear and cytosolic fractions, and the low yields produced precluded replicate western blot analysis. As such, statistical data presented were interpreted with extreme caution, and statistical significance was only noted for data sets that showed significance through two-way ANOVA and non-parametric Kruskal-Wallis analysis ( $P < 0.05$ ). We did refine our protein extraction method to increase yield, but due to time constraints, could not repeat all of the exposures. Again, epithelial cells would have been a better choice for these studies, but polymorphic *NRF2* epithelial cells were not commercially available at the time of our study.

Oxidative agents were selected based on previous studies, which show significant *NRF2* induction in response to hyperoxia, BHT and LPS (Chan 1999; Cho 2002; Rushworth 2005). Of the agents studied, LPS exposure to serum starved cells resulted in higher levels of *NRF2* induction and downstream activity as compared to hyperoxia and BHT. Lymphoblasts may be more resistant to hyperoxia exposure because they aggregate in solution, protecting cells on the interior from oxidative exposure. BHT is used as a food preservative and can be classified both as an antioxidant or an oxidant. Because of its dual role, it can cause fluctuations in antioxidant expression as shown for GPx2, with widely varying levels between cell lines basally and following exposure. Since BHT is ingested with food, the most affected area is the gastrointestinal system, and epithelial cells of the intestinal tract may be more susceptible to its oxidative effects. GPx2 is highly expressed in the gut and lung and is most likely a direct target of BHT. GPx2 levels were lowest in *NRF2* variant cells following exposure, which could increase susceptibility to ROS produced by this phenolic compound. NQO1 and HO1 expression was also lower in *NRF2* variant cells after 24 hours of BHT treatment, suggesting activity of these antioxidants is also adversely affected by mutation to the *NRF2* ARE.

As our results have shown, the quantitative balance of *NRF2* and Maf in the activating complex serves as a molecular switch to activate antioxidants during oxidative stress. Ratios of Maf abundance repress activity of HO1, GPx2 and GSR after oxidative exposure, while NQO1 expression varies based on oxidative treatment. As shown previously, minimal two-fold overabundance of small Maf represses *nrf2* transcriptional

activity (Motohashi 2002). We observed a similar reduction in *NRF2* transcriptional activity with ratios 1:2 or higher. *NRF2* abundance, on the other hand, did not significantly affect downstream protein expression, suggesting that the quantity of Maf protein in the *NRF2*:Maf complex determines antioxidant activity.

In our experiments mutation to the *NRF2* ARE skewed *NRF2*:Maf ratios toward Maf abundance, and resulted in antioxidant repression. The sequence context of the *NRF2* ARE influenced *NRF2* and thus Maf abundance, which in turn affected the composition of the transactivating complex that regulates antioxidant activity. Small Maf repress transcription factor activity by sequestering target gene loci within heterochromatin and thus prevent access to the ARE for activation (Katsuoka 2005). The variation at -617 in the ARE could also affect Maf recruitment, orientation of the activating transcription complex, or alter binding affinity to downstream ARE sequences. The cellular consequences of decreased function and diminished antioxidant activity of *NRF2* ARE variants will be addressed in subsequent studies and are likely to include diminished binding and loss of enzymatic activity. An *NRF2* ARE with weakened transactivation capacity during oxidative stress is expected to produce detrimental effects on cellular function.

**Table 5. Antioxidant primers for ARE consensus sequence verification.** ARE sequences within 1 kb from the transcription start site were confirmed for each cell line. Primers for *NRF2* sequencing are listed in Table 1 (Chapter 1).

<b>Antioxidant</b>	<b>ARE flanking primer</b>	<b>Amplified Size (bp)</b>	<b>Annealing Temp (°C)</b>
NQO1	5'-GCC TTA GCT CAT GGG AAA CA -3' 5'-GCA GAA AAA GAG CCG GAT G-3'	263	56
HO1	5'-CGC TCT CTG GAA TTT CCT TAT C-3' 5'-CGA CTT TAA GGG AAG GTG GA-3'	446	56
GPx2	5'-GCA GGA AGT TGT AAA TCA CTG-3' 5'-GGA AAG CTG AAA TAC TGG TC-3'	274	56
GSR	5'-GCC ATG CTT CCA CTC AAA TG-3' 5'-GCG AGG TAA TTG ACG GAC AGT-3'	293	56

**Table 6. Antibodies and dilutions used for Western blot analysis.** Primary antibodies are listed below, along with commercial vendors shown in parentheses. Secondary antibodies were applied at a dilution of 1:5000 and expression detected using horseradish peroxidase. \* Vendors: (1) Santa Cruz; (2) ABcam; (3) StressGene; (4) BioRad

<b>Primary antibody*</b>	<b>Dilution</b>	<b>Secondary antibody*</b>	<b>Protein size</b>
Rabbit polyclonal NRF2 (1)	1:1000	Goat anti-rabbit IgG HRP (4)	~100 kDa
Rabbit polyclonal Maf (1)	1:1000	Goat anti-rabbit IgG HRP (4)	25 kDa
Goat polyclonal NQO1 (2)	1:300	Donkey anti-goat IgG HRP (1)	35 kDa
Rabbit polyclonal HO1 (3)	1:5000	Goat anti-rabbit IgG HRP (4)	32 kDa
Goat polyclonal GPx2 (2)	1:2000	Donkey anti-goat IgG HRP (1)	30 kDa
Rabbit polyclonal GSR (2)	1:2000	Goat anti-rabbit IgG HRP (4)	58 kDa
Goat polyclonal lamin B (1)	1:500	Donkey anti-goat IgG HRP (1)	60 kDa
Goat polyclonal actin (1)	1:500	Donkey anti-goat IgG HRP (1)	45 kDa

**Table 7. Ratio of NRF2:small Maf in the activating complex.** Western blots were quantitated for NRF2 and small Maf and ratios expressed as NRF2:small Maf (values listed were rounded to the nearest 0.5).

Experiment	Exposure	Wildtype	Heterozygote	Variant
Hyperoxia serum complete (Fig 1)	Air	1:1	2:1	2:1
	4 hr 95% O <sub>2</sub>	1:1	1:1	2:1
	8 hr 95% O <sub>2</sub>	1:1	4:1	1:1
Hyperoxia serum starved (Fig 2)	Air	1:1	1:1	1:2
	0.5 hr 95% O <sub>2</sub>	2:1	1.5:1	1:2.5
	1 hr 95% O <sub>2</sub>	1:1	1:1	1:1
	2 hr 95% O <sub>2</sub>	1:1	2:1	1:2
LPS serum complete (Fig 3)	PBS	1:1	1:1	1:1.5
	3 hr LPS	1:1	2:1	1:1.5
	6 hr LPS	1:1.5	1:1.5	1:3
LPS serum starved (Fig 4)	PBS	1:1	4:1	1:5
	0.5 hr LPS	2:1	10:1	1:3
	1 hr LPS	3.5:1	10:1	1:3
	2 hr LPS	5:1	4.5:1	1:6
BHT serum complete (Fig 5)	DMSO	1:1	1:1	1:3
	8 hr BHT	1:1	1:1	1:2
	24 hr BHT	1:1	1:3	1:2
BHT serum starved (Fig 6)	DMSO	1:1	1:1	1:1
	0.5 hr BHT	1:1	1:1	1:1.5
	1 hr BHT	1:1	1:1	1:1
	2 hr BHT	1:1	1:1	1:1

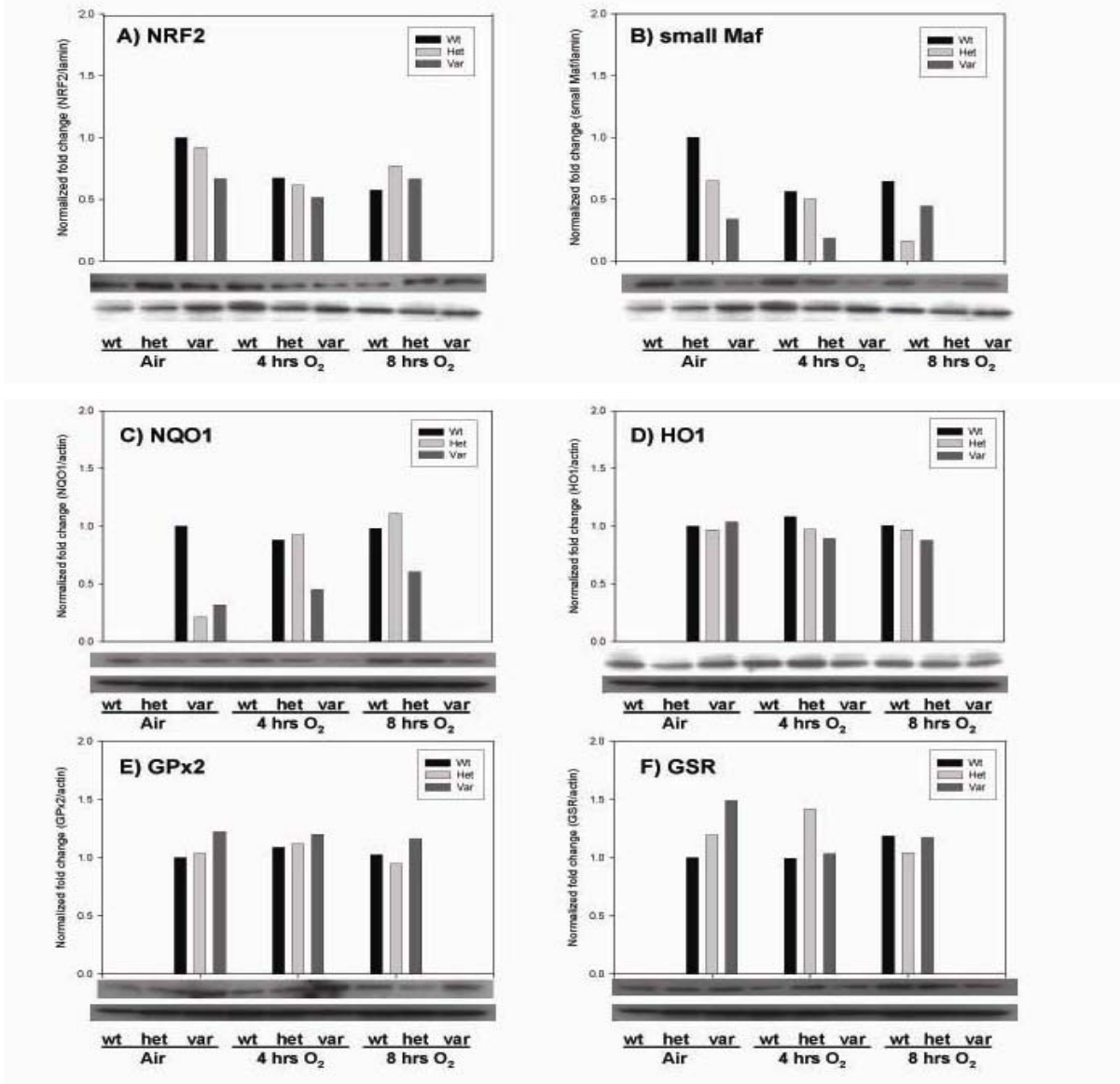

**Figure 1. Protein expression of polymorphic *NRF2* -617 cells exposed to hyperoxia (> 95% oxygen) for 0, 4 and 8 hours.** Nuclear proteins isolated from serum complete lymphoblasts were probed for NRF2 (A) and small Maf (B). Cytosolic fractions were probed for downstream antioxidants NQO1 (C), HO1 (D), GPx2 (E) and GSR (F). Loading control blots are shown in the lower panel below each graph.

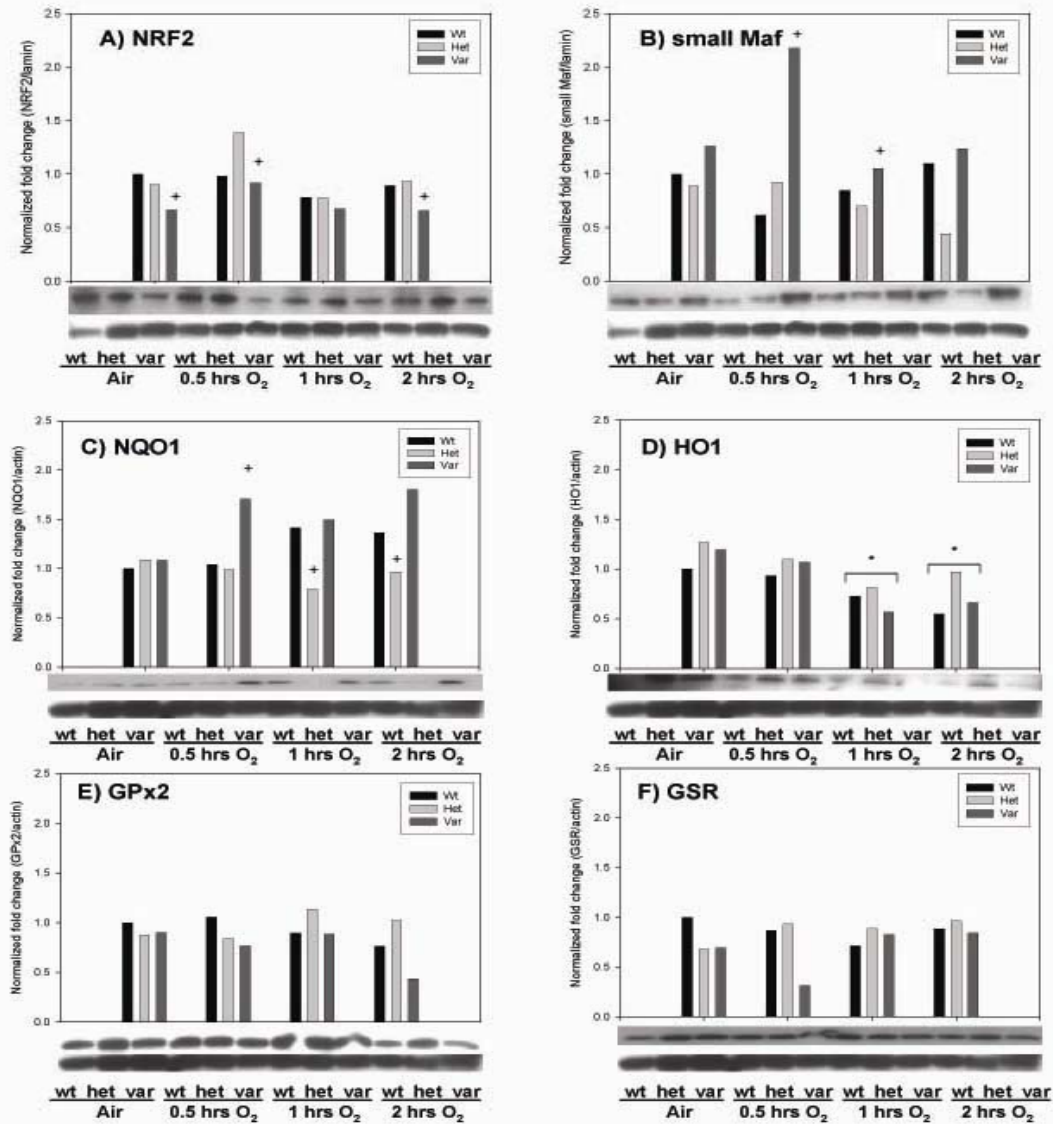

**Figure 2. Protein expression of polymorphic *NRF2* -617 cells exposed to hyperoxia (> 95% oxygen) for 0, 0.5, 1 and 2 hours.** Nuclear proteins isolated from serum starved lymphoblasts were probed for NRF2 (A) and small Maf (B). Cytosolic fractions were probed for downstream antioxidants NQO1 (C), HO1 (D), GPx2 (E) and GSR (F). Loading control blots are shown in the lower panel below each graph. \*P < 0.05 compared with air; +P < 0.05 compared with wildtype.

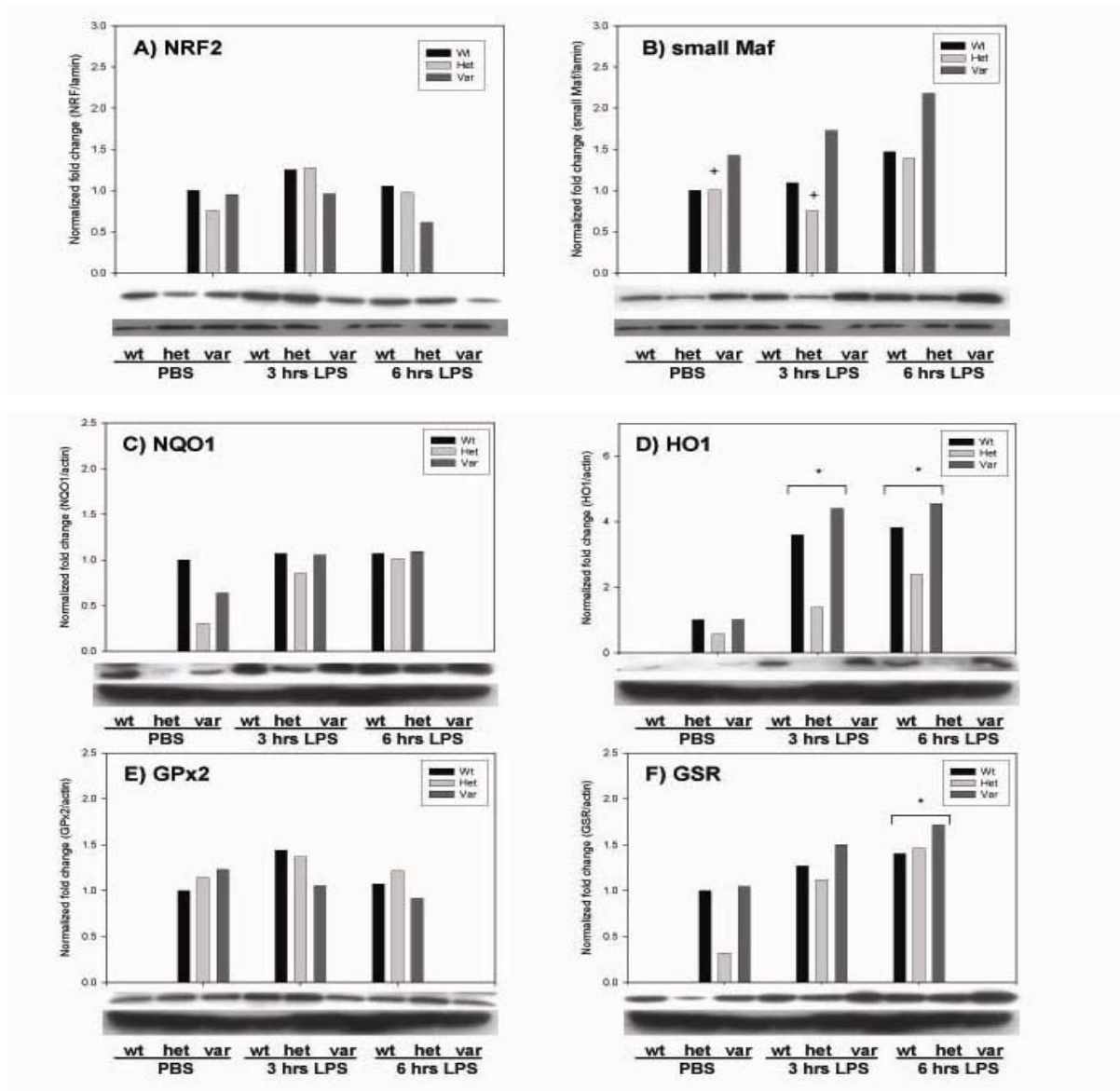

**Figure 3. Protein expression of polymorphic *NRF2* -617 cells exposed to lipopolysaccharide (LPS) for 0, 3 and 6 hours.** Nuclear proteins isolated from serum complete lymphoblasts were probed for NRF2 (A) and small Maf (B). Cytosolic fractions for downstream antioxidants NQO1 (C), HO1 (D), GPx2 (E) and GSR (F). Loading control blots are shown in the lower panel below each graph. \* $P < 0.05$  compared with PBS; † $P < 0.05$  compared with wildtype.

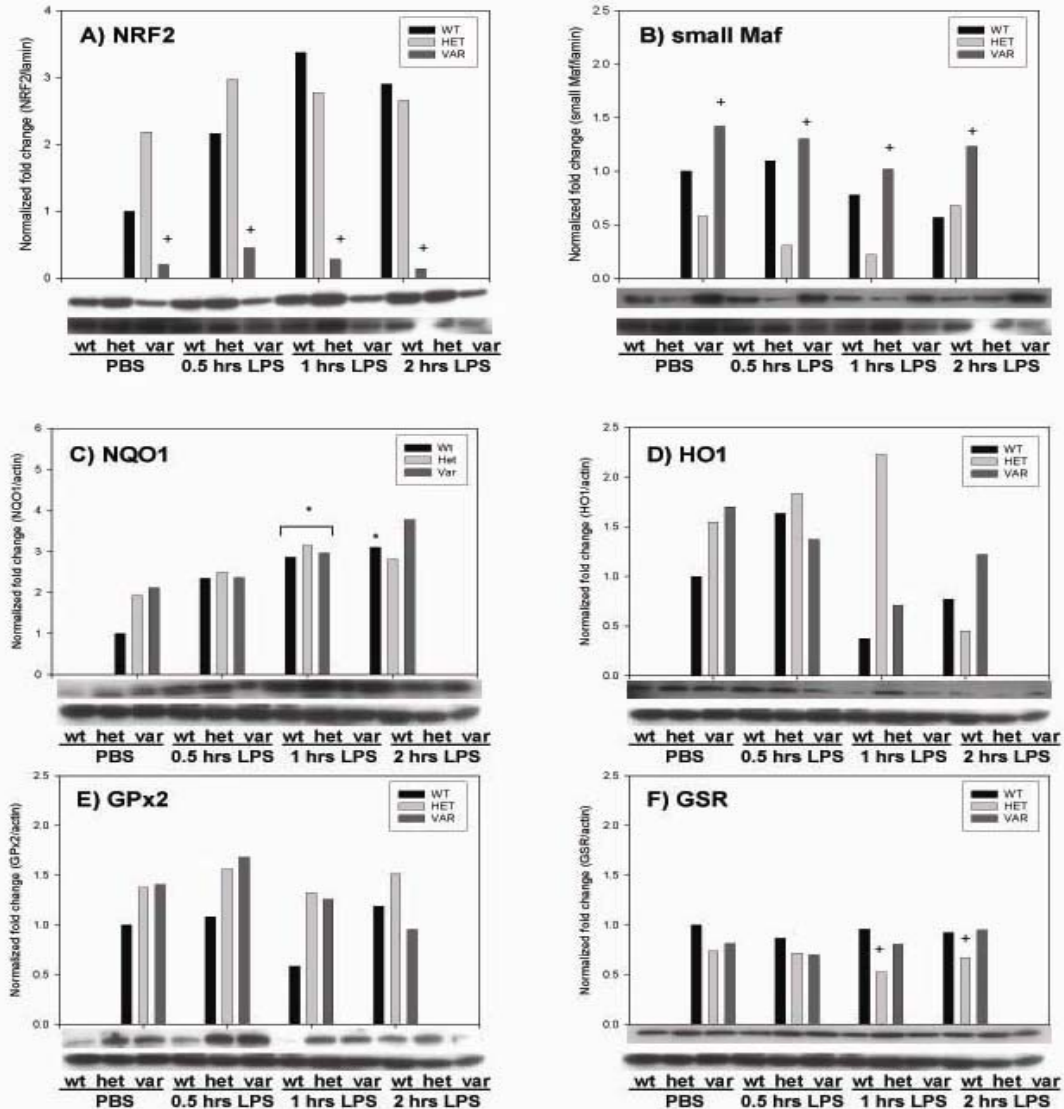

**Figure 4. Protein expression of polymorphic *NRF2* -617 cells exposed to lipopolysaccharide (LPS) for 0, 0.5, 1 and 2 hours.** Nuclear proteins isolated from serum starved lymphoblasts were probed for NRF2 (A) and small Maf (B). Cytosolic fractions for downstream antioxidants NQO1 (C), HO1 (D), GPx2 (E) and GSR (F). Loading control blots are shown in the lower panel below each graph. \* $P < 0.05$  compared with PBS; + $P < 0.05$  compared with wildtype.

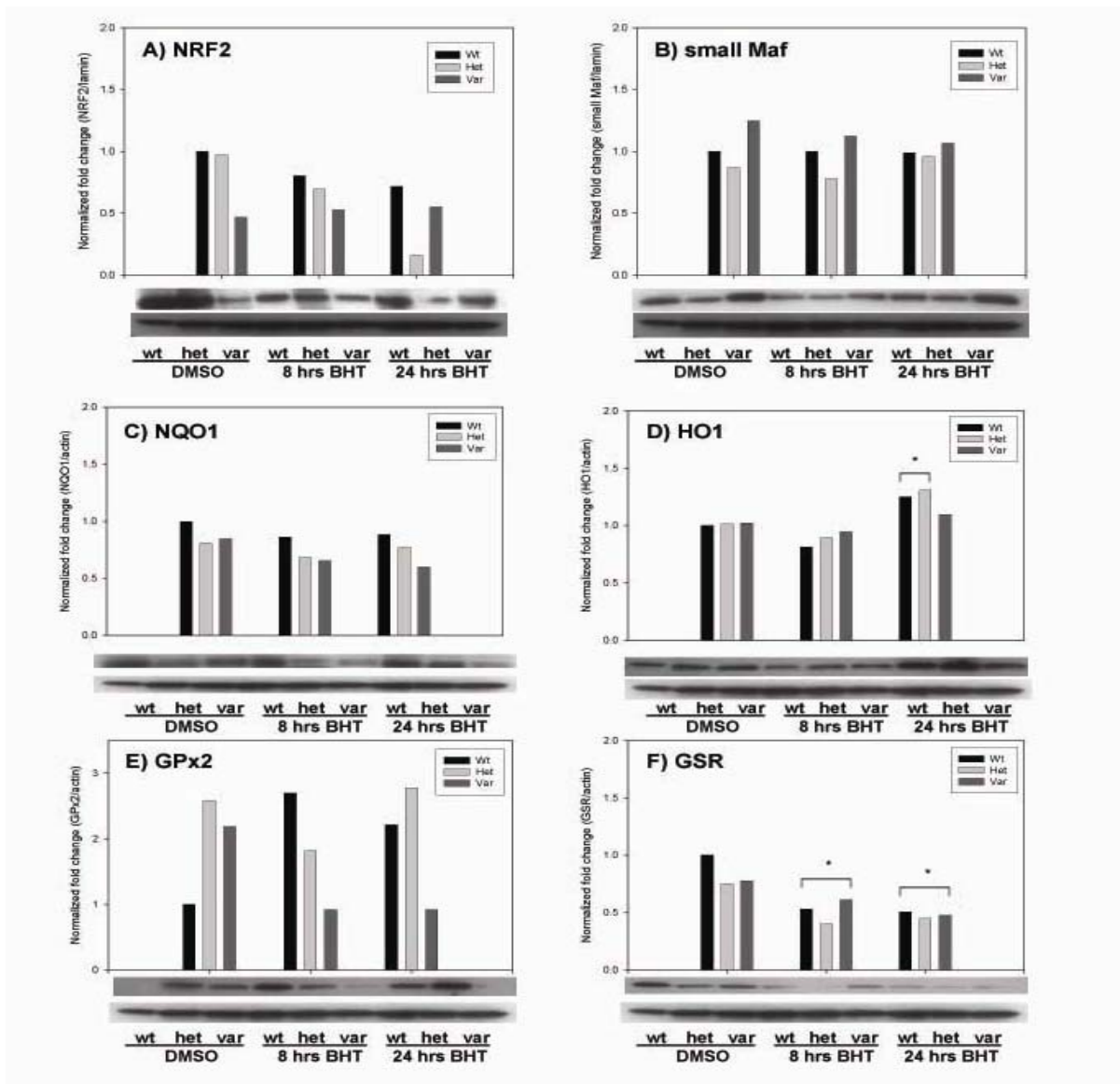

**Figure 5. Protein expression of polymorphic *NRF2* -617 cells exposed to butylated-hydroxytoluene (BHT) for 0, 8 and 24 hours.** Nuclear proteins isolated from serum complete lymphoblasts were probed for NRF2 (A) and small Maf (B). Cytosolic fractions for downstream antioxidants NQO1 (C), HO1 (D), GPx2 (E) and GSR (F). Loading control blots are shown in the lower panel below each graph. \* $P < 0.05$  compared with DMSO.

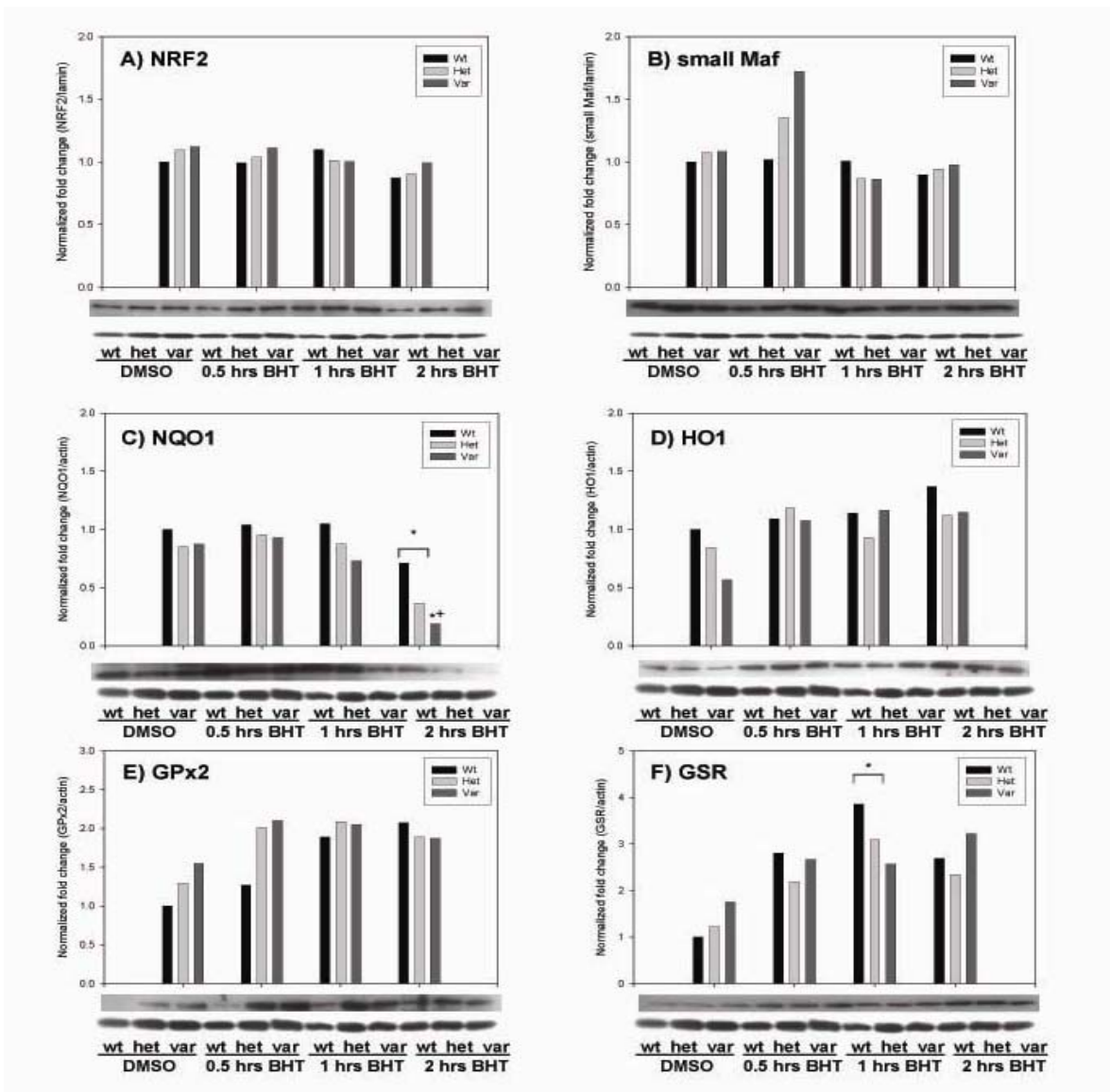

**Figure 6. Protein expression of polymorphic *NRF2* -617 cells exposed to butylated hydroxytoluene (BHT) for 0, 0.5, 1 and 2 hours.** Nuclear proteins isolated from serum starved lymphoblasts were probed for NRF2 (A) and small Maf (B). Cytosolic fractions for downstream antioxidants NQO1 (6C), HO1 (6D), GPx2 (6E) and GSR (6F). Loading control blots are shown in the lower panel below each graph. \* $P < 0.05$  compared with DMSO; + $P < 0.05$  compared with wildtype.

## References

- Bloom, D. A., Jaiswal, A.K. (2003). "Phosphorylation of Nrf2 at Ser40 by protein kinase C in response to antioxidants leads to the release of Nrf2 from INrf2, but is not required for Nrf2 stabilization/accumulation in the nucleus and transcriptional activation of antioxidant response element-mediated NAD(P)H:quinone oxidoreductase-1 gene expression." Journal of Biological Chemistry **278**(45): 44675-44682.
- Chan, K., Kan, Y.W. (1999). "Nrf2 is essential for protection against acute pulmonary injury in mice." Proceedings from the National Academy of Sciences USA **96**(22): 12731-12736.
- Cho, H., Jedlicka, A.E., Reddy, S.P., Kensler, T.W., Yamamoto, M., Zhang, L.Y., Kleeberger, S.R. (2002). "Role of NRF2 in protection against hyperoxia lung injury in mice." American Journal of Respiratory Cell and Molecular Biology **26**(2): 175-182.
- Gerritsen, M. E., Williams, A.J., Neish, A.S., Moore, S., Shi, Y., Collins, T. (1997). "CREB-binding protein/p300 are transcriptional coactivators of p65." Proceedings from the National Academy of Sciences USA **94**(7): 2927-2932.
- Kamei, Y., Xu, L., Heinzl, T., Torchia, J., Kurokawa, R., Gloss, B., Lin, S.C., Heyman, R.A., Rose, D.W., Glass, C.K., Rosenfeld, M.G. (1996). "A CBP integrator complex mediates transcriptional activation and AP-1 inhibition by nuclear receptors." Cell **85**(3): 403-414.
- Katoh, Y., Itoh, K., Yoshida, E., Miyagashi, M., Fukamizu, A., Yamamoto, M. (2001). "Two domains of Nrf2 cooperatively bind CBP, a CREB binding protein, and synergistically activate transcription." Genes Cells **6**(10): 857-868.
- Katsuoka, F., Motohashi, H., Ishii, T., Aburatani, H., Engel, J.D., Yamamoto, M. (2005). "Genetic evidence that small Maf proteins are essential for the activation of antioxidant response element-dependent genes." Molecular and Cellular Biology **25**(18): 8044-8051.
- Kwok, R. P., Lundblad, J.R., Chrivia, J.C., Richards, J.P., Bachinger, H.P., Brennan, R.G., Roberts, S.G., Green, M.R., Goodman, R.H. (1994). "Nuclear protein CBP is a coactivator for the transcription factor CREB." Nature **370**(6486): 223-226.
- Motohashi, H., et al (2002). "Integration and diversity of the regulatory network composed of Maf and CNC families of transcription factors." Gene **294**: 1-12.
- Ngugen, T., et al (2004). "The pathways and molecular mechanisms regulating Nrf2 activation in response to chemical stress." Free Radical Biology & Medicine **37**(4): 433-441.
- Nioi, P., McMahon, M., Itoh, K., Yamamoto, M., Hayes, J.D. (2003). "Identification of a novel Nrf2-regulated antioxidant response element (ARE) in the mouse NAD(P)H:quinone oxidoreductase 1 gene: reassessment of the ARE consensus sequence." Biochemical Journal **374**(Pt 2): 337-348.

Numazawa, S. (2004). "Nrf2 dependent gene expressions: A molecular toxicological aspect." Journal of Toxicological Science **29**(2): 81-89.

Papaiahgari, S., Kleeberger, S.R., Cho, H-Y, Kalcakolanu, D.V., Reddy, S.P. (2004). "NADPH Oxidase and ERK signaling regulated hyperoxia-induced Nrf2-ARE transcriptional response in pulmonary epithelial cells." Journal of Biological Chemistry **279**: 42302-42312.

Rushworth, S. A., Chen, X.L., Mackman, N., Ogborne, R.M., O'Connell, M.A. (2005). "LPS-induced HO1 expression in human monocytic cells is mediated via Nrf2 and PKC." Journal of Immunology **175**(7): 4408-4415.

Zhang, J. J., Vinkemeier, U., Gu, W., Chakravarti, D., Hovarth, C.M., Darnell, J.E. (1996). "Two contact regions between Stat1 and CBP/p300 in interferon gamma signaling." Proceedings from the National Academy of Sciences USA **93**(26): 15092-15096.

Zhu, M., Fahl, W.E. (2001). "Functional characterization of transcription regulators that interact with the electrophile response element." 289(212-219).

## Summary

In conclusion, we identified three promoter mutations in *NRF2* at high frequency (5 to 60%) in a cohort of individuals from four ethnic populations; African descent, European descent, Asian and Native American. Promoter deletion analysis using two constructs (intact *NRF2* promoter and one without the polymorphic site) showed a statistically significant four-fold reduction in luciferase activity with the polymorphic site deleted. Functional analysis of the three mutations indicated the importance of the *NRF2* -617 polymorphism which disrupts an antioxidant response element (ARE). Using *NRF2* polymorphic constructs, we showed a significant decrease in *NRF2* transcription with variant constructs containing the -617 A allele. Through electrophoretic mobility shift assays we noted a reduction in NRF2:DNA binding affinity with -617 C/A heterozygotes and further decreased NRF2:DNA binding with variants carrying two copies of the A allele.

We used commercially available lymphoblast cells containing the -617 SNP (wildtype, *NRF2* heterozygote, *NRF2* variant) to probe for differences in transcription of *NRF2* and downstream antioxidant gene targets (*NQO1*, *HO1*, *GPx2*, *GSR*) following exposure to oxidative stress agents [hyperoxia, LPS and BHT]. Interestingly, serum starved *NRF2* heterozygote cells had significantly higher basal and inducible expression of *NRF2*, *NQO1* and *HO1* compared to wildtype and *NRF2* variant cells, suggesting a significant heterozygosity effect. Significant *NRF2* induction was also observed in serum complete *NRF2* heterozygotes exposed to hyperoxia, with resultant downstream *GPx2* induction. BHT exposure produced significant changes in *GPx2* expression between *NRF2* genotypes for serum complete and serum starved cells. The combined stress of serum starvation coupled with oxidant exposure had a marked impact on *NRF2* heterozygotes.

We also assessed protein expression changes in our three *NRF2* -617 cell lines and probed for NRF2, the co-activator small Maf, as well as downstream antioxidants (NQO1, HO1, GPx2, GSR). Decreased NRF2 expression was noted in serum starved cells exposed to hyperoxia or LPS, and significantly higher small Maf protein expression was seen in the *NRF2* variant cells. Serum complete cells showed a similar response to LPS or BHT, with a reduction in NRF2 expression in *NRF2* variants. Antioxidant expression of HO1, GPx2 and GSR was significantly reduced in *NRF2* variants after serum starvation and exposure to hyperoxia or LPS. NQO1 expression was markedly decreased in *NRF2* variants exposed to hyperoxia and BHT treatment coupled with serum starvation, while GPx2 activity was

reduced in *NRF2* variants after BHT treatment alone. The ratio of the NRF2:small Maf co-activating complex significantly affected expression of NRF2 target enzymes. Maf abundance skewed NRF2:Maf ratios to 1:2 and 1:3, which impacted HO1, GPx2 and GSR expression, while ratios of NRF2 excess affected NQO1. The quantitative balance between NRF2 and small Maf may directly influence cellular defense against oxidative stress.

There are many potential limitations of our studies, foremost the selection of lymphoblast cells for our oxidative exposures. Previous functional studies have focused on epithelial cells and macrophages, which are recruited to the lung as a means of defense against oxidative insult. Lymphoblasts are progenitors of lymphocytes which as early immune cells have not been primed for antigen response. However, lymphocytes have been detected in bronchial lavage fluid from mice exposed to hyperoxia (Cho 2002), but at lower numbers than epithelial and macrophage cells. And as we have shown, with the addition of stress from serum starvation, lymphoblasts do react to oxidative stress agents. Because serum starvation is a confounding factor in our analysis, we would like to repeat oxidative treatment on serum complete cells at shorter exposure times. We also plan to generate primary epithelial cell lines from individuals with *NRF2* promoter mutations and expose them to oxidative agents in order to assess the combined effect of *NRF2* genotype and oxidative exposure.

Doses used for exposure were gathered from literature sources and a dose response was used for BHT treatment. BHT doses greater than or equal to 50  $\mu$ M caused extensive cell death, but at 25  $\mu$ M did not show significant induction of *NRF2*. This could be related to the dual role of BHT as a pro-oxidant and antioxidant, and cells may be protected from ROS overload by its scavenging activity. Similarly, LPS has been shown to be protective against apoptosis, and may prevent oxidative stress in serum starved cells. Additional agents such as tBHQ and sulforaphane will be tested in future studies to confirm transcription and translation changes between *NRF2* genotypes.

We also plan to assess oxidative cell death in the lymphoblast cells, as well as epithelial cells. To do this, we will use annexin V assays and quantitate overall cell death. In addition, we would like to look at markers of injury including TNF $\alpha$  by ELISA as well as other cytokines upregulated in response to oxidative stress. Ultimately, we hope to associate

the *NRF2* ARE variation with decreased function and susceptibility to oxidative damage in human cohorts of lung disease such as acute lung injury.