

# A Queueing Model of a Bufferless Synchronous Clos ATM Switch with Head-of-Line Priority and Push-Out

Arne A. Nilsson  
Fuyung Lai

Center for Communications and Signal Processing  
Department Electrical and Computer Engineering  
North Carolina State University

TR-90/21  
December 1990

# A Queueing Model of a Bufferless Synchronous Clos ATM Switch with Head-Of-Line Priority and Push-out \*

Arne A. Nilsson and Fuyung Lai

Department of Electrical and Computer Engineering, and  
Center for Communications and Signal Processing  
North Carolina State University  
Raleigh, N.C. 27695-7914

Harry G. Perros

Department of Computer Science, and  
Center for Communications and Signal Processing  
North Carolina State University  
Raleigh, N.C. 27695-8206

1990

## Abstract

We consider a synchronized bufferless Clos ATM switch with input cell processor queues. The arrival process to each input port of the switch is assumed to be bursty and it is modeled by an Interrupted Bernoulli Process. Two classes of cells are considered. Service in an input cell processor queue is head-of-line without preemption. In addition, *push-out* is used. That is, a high priority cell arriving to a full queue takes the space occupied by the low priority cell that arrived last, as long as the cell is not in service. Each cell processor queue is modeled as a priority IBP/Geo/1/K+1 queue with push-out. We first present an exact analysis of this priority queue. The results obtained are then used in an approximation algorithm for the analysis of the ATM switch. Validation tests using simulation data shows that the approximation algorithm has a good accuracy.

---

\*Supported in part by DARPA under grant no. DAEA18-90-c-0039.

# 1 Introduction

Broadband ISDN is a promising communications infrastructure for the future. It is conceived as an all-purpose digital network, and it will provide an integrated access that will support a wide variety of applications for the customers. The Asynchronous Transfer Mode (ATM) has been strongly promoted as the target transfer mode solution for broadband ISDN. ATM is a high-bandwidth, low-delay, packet switching technique, capable of efficiently multiplexing a number of highly bursty sources, such as voice, file transfer, and video.

In recent years, several types of ATM switch architectures have been proposed. One important class of architectures is based on *multi-stage interconnection networks*. There are buffered or unbuffered switching elements in a multi-stage interconnection network. In the unbuffered case, there may be buffers at the input ports or at the output ports of the switch. This type of structures have been reported in Turner [1], Narasimha [2], Huang and Knauer [3], Giacobelli, Littlewood, Sincoskie [4], and Tobagi and Kwok [5]. Some switch architectures provide full connectivity between the input and output ports, such as the bus-matrix switching architecture (Nojima [6]), the knockout switch (Yeh, Hluchyj, and Acampora [7]), and the integrated switch fabric (Ahmadi [8]).

Other architectures that have been proposed are the *shared memory* and the *shared medium* architectures. In the shared memory architecture, a single memory is shared by all input and output ports. There is a single controller to process the incoming and outgoing cells which are stored in the same memory. Examples of this type of architecture are discussed in Devault, Cochenec, and Serval [9], and Kuwahara, Endo, Ogino and Kozuki [10]. In the shared medium architecture, arriving cells are multiplexed onto a parallel bus. An example of this architecture is discussed in Suzuki [11]. A good review of ATM switch architectures is given in Tobagi [12]. Approximate analytic studies of ATM switches can be found in Karol, Hluchyj and Morgan [13], Hluchyj and Karol [14], Patel [15], Yoon, Lee, and Liu [16], Shaikh, Schwartz, and Szymanski [17], Oie, Suda, Masayuki, and Miyahara [18], and Yamashita, Perros and Hong [19].

Different classes of service provided by an ATM network will require different quality of service. In particular, voice and video are tolerant to cell loss but not to time delays. On the other hand, the transfer of bulk files is tolerant to time delays but not to cell loss. In view of this, it has been proposed to introduce priorities among cells. These priorities are known as space priorities, as they deal with priorities regarding the utilization of the space in a buffer. Space priorities can be also used in conjunction with congestion control at the call level.

Two different space priority schemes have been proposed, namely, *push-out* and *partial buffer sharing*. In these two schemes, there are high or low priority cells. In the push-out policy, high and low priority cells are admitted to the buffer as long as there is space available. A low priority cell is lost if it arrives to a full buffer. A high priority cell that

arrives to a full buffer, takes the place occupied by the low priority cell that arrived last, as long as this cell is not in service. A high priority cell is lost only if there are no low priority cells in the buffer waiting for service. In the partial buffer sharing scheme, both high and low priority cells are admitted to the buffer as long as the total number of cells in the buffer is below a pre-defined threshold. Once the threshold is exceeded, only high priority cells are admitted to the buffer. Garcia and Casals [20] analyzed a finite capacity single server queue with two classes assuming partial buffer sharing. The arrival process was modelled by a two-state Markov Modulated Poisson Process, and the service time was assumed to be constant. A similar model was considered by Le Boudec [21] assuming a number of identical arrival streams, each being modelled by a two-state Markov Modulated Bernoulli Process. Kröner, Hébuterne, Boyer, and Gravey [22] compared the two space priority schemes. They concluded that both schemes have a comparable performance, though the partial buffer sharing scheme is easier to implement. Their results, however, have been obtained under the assumption of Poisson arrivals. Gravey and Hébuterne [23] analyzed an M/G/1/n queue with head-of-line non-preemptive priority and push-out. The partial buffer sharing scheme was also considered by Yin, Li, and Stern [25]. Conservation laws for the push-out scheme were given in Sumita and Ozawa [24]. Finally, for a literature review of ATM related papers see Perros [26].

In this paper, we study a blocking ATM switch with finite buffer at the input ports. The switch fabric is a bufferless Clos three-stage interconnection network. The arrival process to each input port of the switch is assumed to be bursty, and it is modelled by an Interrupted Bernoulli Process (IBP). Each input queue is assumed to have space and service priority. In particular, we consider push-out for space priority and head-of-line with no preemption for service priority. We now proceed to describe the switch under study in detail.

## 2 Model description

Let us consider an  $N \times N$  Clos cell switch, as shown in Figure 1. There are three stages in the switch. At each stage, there are  $n$  or  $\sqrt{N}$  number of bufferless switching elements. Each switching element is an  $n \times n$  crossbar switch. For each input port, there is a finite queue served by a cell processor. There are two classes of cells, high and low priority. If an arriving high priority cell finds the buffer of the cell processor full, it will push out a low priority cell with the least waiting time in the system, but not the one in service. An arriving low priority cell is lost if it finds the buffer full. An arriving high priority cell is lost only if the buffer is full with high priority cells. High priority cells have also priority for service over low priority cells. The service priority is head-of-line with no preemption.

The cell processor is responsible for determining the output port of a cell and then transmitting the cell through the switch fabric. The operation of the Clos switch is synchronous. That means, at the beginning of a time slot all the busy cell processors will

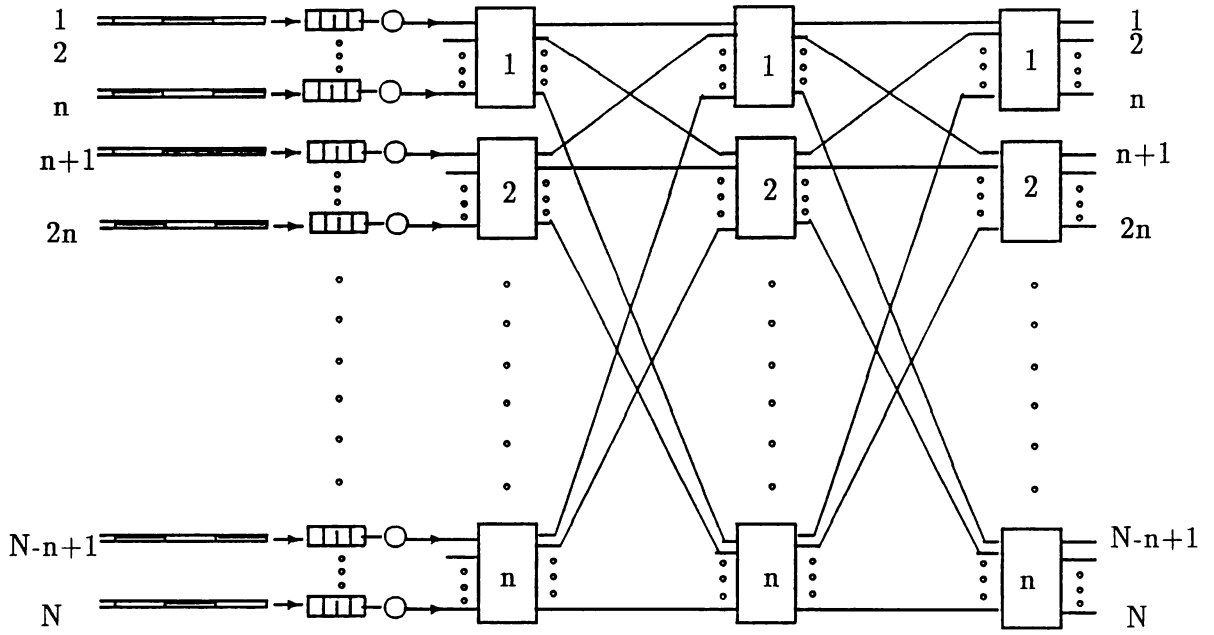

Figure 1: Synchronous  $N \times N$  Clos ATM Switch.

launch a cell through the switch. A cell will successfully get through the switch if it finds a free path to the sought output port. No contention takes place at the 1st stage of the Clos ATM switch. The cells in the switch will compete for the output links at the 2nd and the 3rd stages. In a switching element, if more than one input link compete for the same output link, one of the input links will get through. This input link is randomly selected. If a cell is blocked in the switch, the switching element notifies the cell processor, and transmission of the cell is aborted. The cell processor will retransmit the cell at the beginning of the next time slot. The retransmissions will continue until the cell is successfully transmitted through the switch.

The time required for a cell to pass through the switch fabric is equal to one slot. It is assumed that each incoming link is slotted. The length of a slot is equal to a slot of the ATM switch. Each incoming link is not synchronized with the other incoming links and with the switch. A cell that arrives at an idle cell processor in the middle of a slot of the ATM switch is not transmitted until the beginning of the next time slot of the ATM switch.

The arrival process to each input port of the ATM switch is modeled by an Interrupted Bernoulli Process (IBP), as shown in Figure 2. No arrivals occur if the process is in the idle state. If the process is in the active state, arrivals occur in a Bernoulli fashion. That is, a slot will contain a cell with probability  $\alpha$ . If the process is in the idle (active) state, then in the next time slot it remains in the idle (active) state with probability  $q$  ( $p$ ) or it will change to the active (idle) state with probability  $1 - q$  ( $1 - p$ ). It can be shown (see Nilsson,

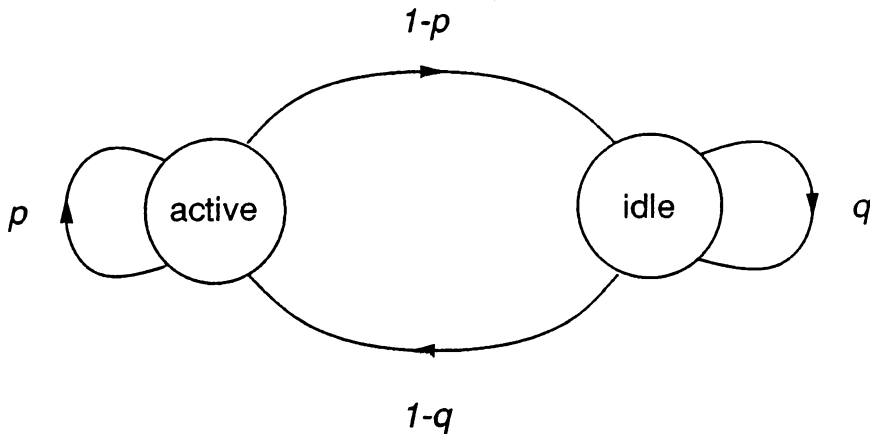

Figure 2: The Markov chain of the IBP process.

Lai, and Perros [27]) that the z-transform of the probability distribution of the interarrival time is

$$A(z) = \frac{z\alpha[p + z(1 - p - q)]}{(1 - \alpha)(p + q - 1)z^2 - [q + p(1 - \alpha)]z + 1}$$

From this we have that the mean interarrival time  $E(\tilde{t})$  is equal to

$$E\{\tilde{t}\} = \frac{(2 - p - q)}{\alpha(1 - q)}, \quad (1)$$

and the squared coefficient of variation of the interarrival time,  $C^2$ , is

$$C^2 = 1 + \alpha \left( \frac{(1 - p)(3 - q)}{(2 - p - q)^2} - 2 \right) + \alpha^2 \frac{(1 - q)^2}{(2 - p - q)^2}. \quad (2)$$

Assuming that the destination of a cell is uniformly selected, it can also be shown that the probability for a cell successfully passing through the Clos ATM switch,  $1 - \sigma$ , is

$$\begin{aligned} 1 - \sigma &= \frac{\text{Average number of busy output links at the 3rd stage}}{\text{Average number of busy input links at the 1st stage}} \\ &= \frac{\sum_{i=1}^N \rho_i^{[3]}}{\sum_{i=1}^N \rho_i}, \end{aligned} \quad (3)$$

where  $\rho_i^{[3]}$  is the  $i$ th output link utilizations of the switching elements in the 3rd stage of the Clos ATM switch.

In this paper, we analyze the buffer in front of a cell processor as a two-class IBP/Geo/1/K+1 queue with head-of-line non-preemptive priority and push-out. In section 3, we obtain the queue-length distribution of the number of high and low priority cells that are waiting to be served, as seen by an arriving cell. We also obtain the distribution of the waiting time of a high priority cell. In section 4, we obtain the probability that a low priority cell will get served given that it entered the buffer. We also compute the mean waiting time of a low priority cell given that it entered the buffer and it got served. In section 5, we analyze the ATM switch, following the simple approximation algorithm described in Nilsson, Lai, and Perros [27]. Finally, numerical results are given in section 6 and conclusions are given in section 7.

### 3 The IBP/Geo/1/K+1 queue with head-of-line priority and push-out

Let us consider a cell processor queue. It is obvious from the previous section that the total time it takes for the cell processor to transmit successfully a high or low priority cell through the switch fabric is geometrically distributed with probability  $\sigma$ . Therefore, a cell processor queue can be modeled as an IBP/Geo/1 queue with finite buffer, head-of-line priority, and push-out, as shown in Figure 3. In the analysis below, we will consider this queuing system

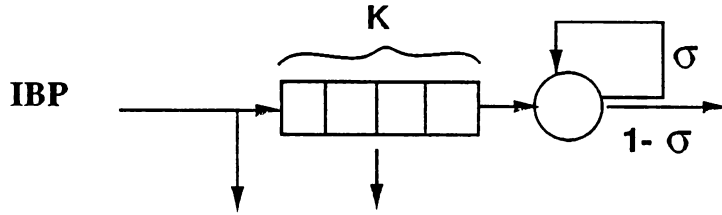

Figure 3: The IBP/Geo/1 queueing system with finite buffer.

at successive arrival points as shown in Figure 4. These arrival points are the imbedded Markov points of the queuing system. Our approach is to focus attention on arrival instants and the *number of high and low priority customers seen by an arriving customer*.

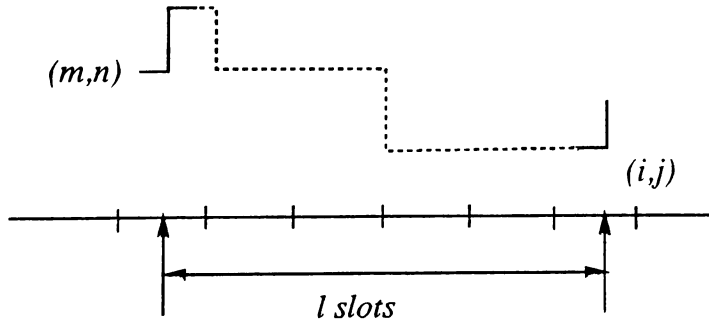

Figure 4: The evolution of the number of customers in the system.

Below, we distinguish between the *queue* that is allowed to be built in front of the server, and the *system* that includes the queue and the server. Let  $K$  be the queue size, and  $K+1$  be the system size. Let  $(i,j)$  be the state of the queue as seen by an arriving cell, where  $i$  is the number of high priority cells and  $j$  is the number of low priority cells in the queue. The state  $(0,0)$  means that there are no cells in the queue. Finally, state 0 means that the entire system is empty.

In order to analyze the queuing system we introduce the following notation



$\beta$  : the probability that an arriving cell is a high priority cell.

$P_{i,j}$  : the probability that an arriving cell finds the queue in state  $(i,j)$ .

$P_0$  : the probability that an arriving cell finds an empty system.

$\tilde{t}$  : the interarrival time of the cell.

$\tilde{x}$  : the service time of a cell.

We define

$$P[\tilde{t} = l] = a_l, \quad l \geq 1$$

and

$$P[\tilde{x} = i] = (1 - \sigma)\sigma^{i-1}, \quad i \geq 1,$$

where  $a_l$  is the probability that an interarrival time is  $l$  slots, and  $\sigma$  is the probability that a cell is blocked in the Clos ATM switch.

Below, we obtain the probability  $P_{i,j}$  and we also obtain the waiting time distribution of a high priority cell.

### 3.1 The queue length distribution $P_{i,j}$

We first note that in Nilsson, Lai, and Perros [27], the steady state probability  $\gamma_j$  that an arriving cell sees  $j$  cells in the system was obtained for an IBP/Geo/1 queue with finite buffer. We observe that

$$\begin{aligned} P_0 &= \gamma_0, \\ P_{0,0} &= \gamma_1. \end{aligned}$$

Let us define

$$b_j = \frac{(1 - \sigma)^j A^{(j)}(\sigma)}{j!}, \quad b_0 = A(\sigma),$$

where  $A(z)$  is the  $z$ -transform of the probability distribution of the interarrival time. In order to obtain  $P_{i,j}$  we need to study the system at instants of arrivals. In steady state, we have

$$P_{i,j} = \beta \sum_{n=i-1}^{K-1-j} P_{n,j} \sum_{l=1}^{\infty} \binom{l}{n-i+1} \sigma^{l-(n-i+1)} (1 - \sigma)^{(n-i+1)} a_l$$

$$\begin{aligned}
& +\beta P_{K-1-j,j+1} \sum_{l=1}^{\infty} \binom{l}{K-j-i} \sigma^{l-(K-j-i)} (1-\sigma)^{(K-j-i)} a_l \\
& + (1-\beta) \sum_{m=i}^{K-1-(j-1)} P_{m,j-1} \sum_{l=1}^{\infty} \binom{l}{m-i} \sigma^{l-(m-i)} (1-\sigma)^{(m-i)} a_l \\
= & \beta (P_{i-1,j} b_0 + P_{i,j} b_1 + \cdots + P_{K-1-j,j} b_{K-i-j}) + \beta P_{K-1-j,j+1} b_{K-i-j} \\
& + (1-\beta) (P_{i,j-1} b_0 + P_{i+1,j-1} b_1 + \cdots + P_{K-j,j-1} b_{K-i-j}) \\
& \text{for } i, j > 0 \text{ and } i + j < K,
\end{aligned}$$

and

$$\begin{aligned}
P_{i,0} & = \beta \sum_{n=i-1}^{K-1} P_{n,0} \sum_{l=1}^{\infty} \binom{l}{n-i+1} \sigma^{l-(n-i+1)} (1-\sigma)^{(n-i+1)} a_l \\
& + \beta (P_{K,0} + P_{K-1,1}) \sum_{l=1}^{\infty} \binom{l}{K-i} \sigma^{l-(K-i)} (1-\sigma)^{(K-i)} a_l \\
= & \beta (P_{i-1,0} b_0 + P_{i,0} b_1 + \cdots + P_{K-1,0} b_{K-i}) \\
& + \beta P_{K,0} b_{K-i} + \beta P_{K-1,1} b_{K-i} \\
& \text{for } K > i > 0, \text{ and } j = 0,
\end{aligned}$$

and

$$\begin{aligned}
P_{0,j} & = (1-\beta) \sum_{n=0}^{K-1-(j-1)} \sum_{l=1}^{\infty} P_{n,j-1} \binom{l}{n} \sigma^{l-n} (1-\sigma)^n a_l \\
& + \sum_{n=j}^{K-1} \sum_{m=0}^{K-1-n} \sum_{l=1}^{\infty} P_{m,n} \binom{l}{m+1+n-j} \sigma^{l-(m+1+n-j)} (1-\sigma)^{(m+1+n-j)} a_l \\
& + \beta \sum_{n=j+1}^K P_{K-n,n} \sum_{l=1}^{\infty} \binom{l}{K-j} \sigma^{l-(K-j)} (1-\sigma)^{(K-j)} a_l \\
& + (1-\beta) \sum_{n=j}^K P_{K-n,n} \sum_{l=1}^{\infty} \binom{l}{K-j} \sigma^{l-(K-j)} (1-\sigma)^{(K-j)} a_l \\
= & (1-\beta) (P_{0,j-1} b_0 + P_{1,j-1} b_1 + \cdots + P_{K-j,j-1} b_{K-j}) \\
& + P_{0,j} b_1 + P_{1,j} b_2 + \cdots + P_{K-1-j,j} b_{K-j} + (1-\beta) P_{K-j,j} b_{K-j} \\
& + P_{0,j+1} b_2 + P_{1,j+1} b_3 + \cdots + P_{K-1-(j+1),j+1} b_{K-j} + P_{K-(j+1),j+1} b_{K-j} \\
& + \cdots \\
& + P_{0,K-1} b_{K-j} + P_{1,K-1} b_{K-j} \\
& + P_{0,K} b_{K-j} \\
& \text{for } i = 0, \text{ and } K > j > 0,
\end{aligned}$$

For the case  $i + j = K$ , we have

$$P_{K,0} = P_{K,0} \sum_{l=1}^{\infty} \sigma^l a_l + \beta P_{K-1,0} \sum_{l=1}^{\infty} \sigma^l a_l + \beta P_{K-1,1} \sum_{l=1}^{\infty} \sigma^l a_l$$

and

$$P_{0,K} = (1 - \beta)P_{0,K} \sum_{l=1}^{\infty} \sigma^l a_l + (1 - \beta)P_{0,K-1} \sum_{l=1}^{\infty} \sigma^l a_l$$

and

$$\begin{aligned} P_{i,K-i} &= \beta P_{i-1,K-i} \sum_{l=1}^{\infty} \sigma^l a_l + \beta P_{i-1,K-i+1} \sum_{l=1}^{\infty} \sigma^l a_l + \\ &\quad (1 - \beta)P_{i,K-i} \sum_{l=1}^{\infty} \sigma^l a_l + (1 - \beta)P_{i,K-i-1} \sum_{l=1}^{\infty} \sigma^l a_l \\ &\quad \text{for } K > i > 0. \end{aligned}$$

From the above equations, we obtain the transition probability matrix of the system shown in Figure 5. Thus, the steady state probability,  $P_{i,j}$ , can be computed using a numerical method.

	$P_0$	$P_{00}$	$P_{10}$	$P_{01}$	$P_{20}$	$P_{11}$	$P_{02}$	...	$P_{K-2,0}$	$P_{K-3,1}$	...	$P_{1,K-3}$	$P_{0,K-2}$	$P_{K-1,0}$	$P_{K-2,1}$	...	$P_{1,K-2}$	$P_{0,K-1}$	$P_{K,0}$	$P_{K-1,1}$	...	$P_{1,K-1}$	$P_{0,K}$
$P_0$	1	0	0	0	0	0	0	0	0	0	0	0	0	0	0	0	0	0	0	0	0	0	0
$P_{00}$	0	1	0	0	0	0	0	0	0	0	0	0	0	0	0	0	0	0	0	0	0	0	0
$P_{10}$	0	$\beta b_0$	$\beta b_1$	0	$\beta b_2$	0	0	0	0	0	0	0	0	0	0	0	0	0	0	0	0	0	0
$P_{01}$	0	$\beta b_0$	$\beta b_1$	$\beta b_2$	0	0	0	0	0	0	0	0	0	0	0	0	0	0	0	0	0	0	0
$P_{20}$	0	0	$\beta b_0$	0	$\beta b_1$	0	0	0	0	0	0	0	0	0	0	0	0	0	0	0	0	0	0
$P_{11}$	0	0	$\beta b_0$	$\beta b_1$	$\beta b_2$	0	0	0	0	0	0	0	0	0	0	0	0	0	0	0	0	0	0
$P_{02}$	0	0	0	$\beta b_0$	$\beta b_1$	$\beta b_2$	0	0	0	0	0	0	0	0	0	0	0	0	0	0	0	0	0
...	...	...	...	...	...	...	...	...	...	...	...	...	...	...	...	...	...	...	...	...	...	...	...
$P_{K-2,0}$	0	0	0	0	0	0	0	0	$\beta b_1$	0	0	0	0	$\beta b_1$	0	0	0	0	$b_2$	$\beta b_2$	0	0	0
$P_{K-3,1}$	0	0	0	0	0	0	0	0	$\beta b_1$	$\beta b_1$	0	0	0	$\beta b_1$	$\beta b_1$	0	0	0	0	$\beta b_2$	$\beta b_2$	0	0
...	...	...	...	...	...	...	...	...	...	...	...	...	...	...	...	...	...	...	...	...	...	...	...
$P_{1,K-3}$	0	0	0	0	0	0	0	0	0	0	0	0	0	0	0	0	0	0	0	0	0	0	0
$P_{0,K-2}$	0	0	0	0	0	0	0	0	0	0	0	0	0	0	0	0	0	0	0	0	0	0	0
$P_{K-1,0}$	0	0	0	0	0	0	0	0	$\beta b_0$	0	0	0	0	$\beta b_0$	0	0	0	0	$b_1$	$\beta b_1$	0	0	0
$P_{K-2,1}$	0	0	0	0	0	0	0	0	$\beta b_0$	$\beta b_0$	0	0	0	$\beta b_0$	$\beta b_0$	0	0	0	0	$\beta b_1$	$\beta b_1$	0	0
...	...	...	...	...	...	...	...	...	...	...	...	...	...	...	...	...	...	...	...	...	...	...	...
$P_{1,K-2}$	0	0	0	0	0	0	0	0	0	0	0	0	0	0	0	0	0	0	0	0	0	0	0
$P_{0,K-1}$	0	0	0	0	0	0	0	0	0	0	0	0	0	0	0	0	0	0	0	0	0	0	0
$P_{K,0}$	0	0	0	0	0	0	0	0	0	0	0	0	0	0	0	0	0	0	0	0	0	0	0
$P_{K-1,1}$	0	0	0	0	0	0	0	0	0	0	0	0	0	0	0	0	0	0	0	0	0	0	0
...	...	...	...	...	...	...	...	...	...	...	...	...	...	...	...	...	...	...	...	...	...	...	...
$P_{1,K-1}$	0	0	0	0	0	0	0	0	0	0	0	0	0	0	0	0	0	0	0	0	0	0	0
$P_{0,K}$	0	0	0	0	0	0	0	0	0	0	0	0	0	0	0	0	0	0	0	0	0	0	0

\*  $\bar{\beta} = 1 - \beta$

Figure 5: The probability transition matrix of the system.

### 3.2 The Waiting Time Distribution of the High Priority Cell

Let  $x_0$  be the time interval between the arrival instant and the beginning of the next slot, and let  $w$  be the waiting time in the system. We have

$$w = \left\{ \begin{array}{l} x_0 \quad , \frac{1}{1-P_{K,0}} [P_0 + P_{0,0}(1-\sigma)] \\ \\ 1 + x_0 \quad , \frac{1}{1-P_{K,0}} \left[ \sum_{j=0}^K \binom{1}{0} P_{0,j} \sigma (1-\sigma) + \sum_{j=0}^{K-1} \binom{1}{1} P_{1,j} (1-\sigma)(1-\sigma) \right] \\ \\ 2 + x_0 \quad , \frac{1}{1-P_{K,0}} \left[ \sum_{j=0}^K \binom{2}{0} P_{0,j} \sigma^2 (1-\sigma) + \sum_{j=0}^{K-1} \binom{2}{1} P_{1,j} \sigma (1-\sigma)(1-\sigma) \right] \\ \quad + \frac{1}{1-P_{K,0}} \left[ \sum_{j=0}^{K-2} \binom{2}{2} P_{2,j} (1-\sigma)^2 (1-\sigma) \right] \\ \\ 3 + x_0 \quad , \frac{1}{1-P_{K,0}} \left[ \sum_{j=0}^K \binom{3}{0} P_{0,j} \sigma^3 (1-\sigma) + \sum_{j=0}^{K-1} \binom{3}{1} P_{1,j} \sigma^2 (1-\sigma)(1-\sigma) \right] \\ \quad + \frac{1}{1-P_{K,0}} \left[ \sum_{j=0}^{K-2} \binom{3}{2} P_{2,j} \sigma (1-\sigma)^2 (1-\sigma) + \sum_{j=0}^{K-3} \binom{3}{3} P_{3,j} (1-\sigma)^3 (1-\sigma) \right] \\ \\ \vdots \\ \\ K-1 + x_0 \quad , \frac{1}{1-P_{K,0}} \left[ \sum_{i=0}^{K-1} \sum_{j=0}^{K-i} \binom{K-1}{i} P_{i,j} \sigma^{K-1-i} (1-\sigma)^i (1-\sigma) \right] \\ \\ \vdots \\ \\ l + x_0, l \geq K-1 \quad , \frac{1}{1-P_{K,0}} \left[ \sum_{i=0}^{K-1} \sum_{j=0}^{K-i} \binom{l}{i} P_{i,j} \sigma^{l-i} (1-\sigma)^i (1-\sigma) \right] \end{array} \right.$$

The distribution of the waiting time is as follows:

$$P[w = n + x_0] = \left\{ \begin{array}{ll} \frac{1}{1-P_{K,0}} [P_0 + P_{0,0}(1-\sigma)], & n = 0. \\ \frac{1}{1-P_{K,0}} \left[ \sum_{i=0}^n \sum_{j=0}^{K-i} \binom{n}{i} P_{i,j} \sigma^{n-i} (1-\sigma)^i (1-\sigma) \right], & K-1 \geq n \geq 1 \\ \frac{1}{1-P_{K,0}} \left[ \sum_{i=0}^{K-1} \sum_{j=0}^{K-i} \binom{n}{i} P_{i,j} \sigma^{n-i} (1-\sigma)^i (1-\sigma) \right], & n > K-1 \end{array} \right.$$

The mean waiting time of a high priority cell can be obtained by the following argument. Let  $P_{i,j}^h$  be the probability that an arriving high priority cell finds the system in state  $(i,j)$  given that the high priority cell will be accepted into the system and let  $N_{Qh}$  be the average number of high priority cells in front of the arriving high priority cell. We get

$$\begin{aligned} N_{Qh} &= \sum_{i=0}^{K-1} \sum_{j=0}^{K-i} iP_{i,j}^h \\ &= \frac{1}{1 - P_{K,0}} \sum_{i=0}^{K-1} \sum_{j=0}^{K-i} iP_{i,j} \end{aligned}$$

The residual service time  $W_0$  seen by the arriving high priority cell is found as follows :

$$\begin{aligned} W_0 &= \frac{1}{1 - P_{K,0}} \left[ x_0 P_0 + (1 - P_0 - P_{K,0}) \sum_{i=0}^{\infty} (x_0 + i)(1 - \sigma)\sigma^i \right] \\ &= \frac{1}{1 - P_{K,0}} \left[ x_0(1 - P_{K,0}) + \left( \frac{\sigma}{1 - \sigma} \right) (1 - P_0 - P_{K,0}) \right] \end{aligned}$$

Thus,  $W_H$ , the mean waiting time of the high priority cell is :

$$W_H = W_0 + N_{Qh} \frac{1}{1 - \sigma}.$$

## 4 Computation of the probability that a low priority cell will get served and mean waiting time.

In this section, we obtain exact results for the low priority cells. In particular, we calculate the probability that a low priority cell will get served given that it entered the queue. We also obtain the mean waiting time of a low priority cell given that it entered the queue and it got served. The main vehicle for obtaining these results is the one dimensional random walk consisting of the absorbing states 0 and  $K+1$ , as shown in Figure 6.

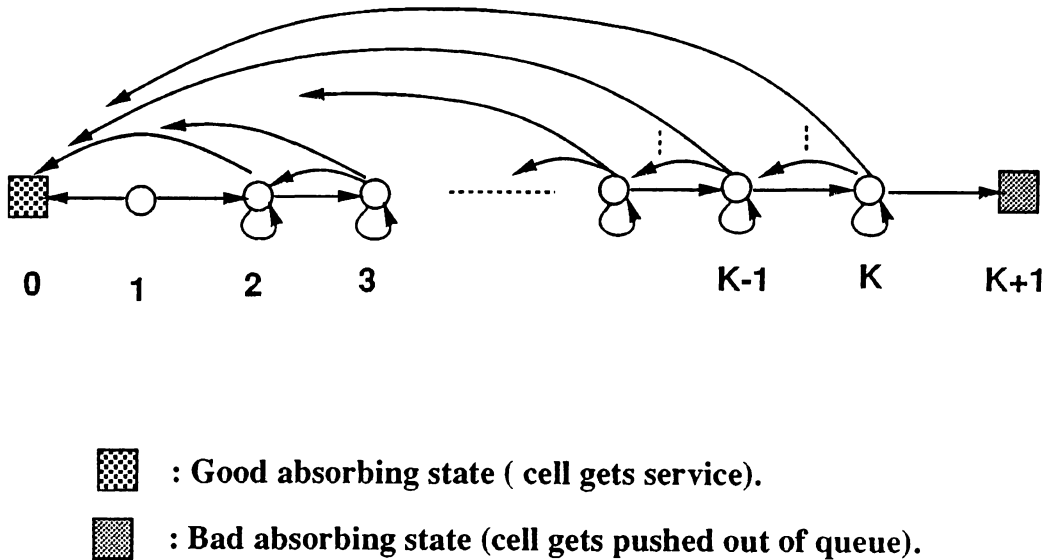

Figure 6: The states of the random walk.

The states of the random walk are defined as follow. We tag a low priority cell when it enters the queue. The state variable of the random walk indicates the position of this tagged cell throughout its residency in the queue immediately after a high priority cell arrives. We note that the positions in the queue are numbered from 1 to  $K$ . The position in front of the server is numbered 0. The tagged unit receives service if the random walk reaches the absorbing state 0, and it is pushed-out if the random walk reaches the absorbing state  $K+1$ . If upon arrival the tagged unit sees  $i$  high priority cells and  $j$  low priority cells in the queue, the random walk will start at state  $i+j+1$ . Transitions will then occur only when a high priority cell arrives. We define our transitions in this way, seeing that only the arrival of a high priority cell may affect the position in the queue of the tagged unit. These transition probabilities are calculated below.

## 4.1 Computation of the transition probabilities

Let  $P_{i \rightarrow j}$  be the transition probability from state  $i$  to state  $j$ . Let  $S_i$  be the probability of having  $i$  cells served during the interarrival time of the high priority cell. Let  $P[t_a = n]$  be the probability that the interarrival time of the high priority cell is  $n$  slots and  $1 - \sigma$  be the probability of having a service completion in one slot. Then, for  $j > 0$ , we have

$$\begin{aligned}
 P_{i \rightarrow j} &= P[(i - j + 1)\text{service completions}] \\
 &= S_{i-j+1} \\
 &= \sum_{n=0}^{\infty} \binom{n}{i-j+1} (1 - \sigma)^{i-j+1} \sigma^{n-(i-j+1)} P[t_a = n] \\
 &= \frac{(1 - \sigma)^{i-j+1}}{(i-j+1)!} \sum_{n=i-j+1}^{\infty} \frac{n!}{(n - (i-j+1))!} \sigma^{n-(i-j+1)} P[t_a = n] \\
 &= \frac{(1 - \sigma)^{i-j+1}}{(i-j+1)!} T_a^{(i-j+1)}(\sigma)
 \end{aligned}$$

and, for  $j = 0$ , we have

$$P_{i \rightarrow 0} = 1 - \sum_{j=0}^{i-1} S_j$$

where  $T_a^{(i-j+1)}$  is the  $(i-j-1)^{th}$  derivative of  $T_a(z)$  at  $z = \sigma$ , and

$$T_a(z) = \sum_{n=1}^{\infty} z^n P[t_a = n].$$

The above generating function is computed as follows. Let  $t_a$  be the time interval from an active state to an arrival of the high priority cell and  $t_i$  be the time interval from an idle state to an arrival of the high priority cell. We have

$$\begin{aligned}
 t_a &= \begin{cases} 1 & , p\alpha\beta \\ 1 + t_a & , p(1 - \alpha\beta) \\ 1 + t_i & , 1 - p \end{cases} \\
 t_i &= \begin{cases} 1 + t_i & , q \\ 1 & , (1 - q)\alpha\beta \\ 1 + t_a & , (1 - q)(1 - \alpha\beta) \end{cases}
 \end{aligned}$$

Hence,

$$\begin{aligned}
 T_a(z) &= zp\alpha\beta + zp(1 - \alpha\beta)T_a(z) + z(1 - p)T_i(z) \\
 T_i(z) &= zqT_i(z) + z\alpha\beta(1 - q) + z(1 - q)(1 - \alpha\beta)T_a(z)
 \end{aligned}$$



We get

$$T_a(z) = \frac{z\alpha\beta[p + z(1 - p - q)]}{(1 - \alpha\beta)(p + q - 1)z^2 - [q + p(1 - \alpha\beta)]z + 1}$$

## 4.2 The probability that a low priority cell will get served

Let  $U_i$  be the probability that the random walk system reaches the absorbing state 0 given that the system starts in state  $i$ . Let  $S_j$  be the probability of having  $j$  cells served in an interarrival time of the high priority cell. We have

$$U_0 = 1 \text{ and } U_{K+1} = 0.$$

To find  $U_i, i = 1, 2, \dots, K$ , we have to solve the following linear equations :

$$\begin{aligned} U_1 &= S_0U_2 + (1 - S_0)U_0 \\ U_2 &= S_0U_3 + S_1U_2 + (1 - \sum_{l=0}^1 S_l)U_0 \\ \dots & \\ \dots & \\ U_{K-1} &= S_0U_K + S_1U_{K-1} + \dots + S_{K-2}U_2 + (1 - \sum_{l=0}^{K-2} S_l)U_0 \\ U_K &= S_0U_{K+1} + S_1U_K + \dots + S_{K-1}U_2 + (1 - \sum_{l=0}^{K-1} S_l)U_0 \end{aligned}$$

Thus, we get :

$$\begin{bmatrix} U_2 \\ U_3 \\ \cdot \\ \cdot \\ \cdot \\ U_K \end{bmatrix} = \begin{bmatrix} S_1 & S_0 & 0 & \cdot & \cdot & \cdot & 0 \\ \cdot & \cdot & \cdot & \cdot & \cdot & \cdot & \cdot \\ \cdot & \cdot & \cdot & \cdot & \cdot & \cdot & \cdot \\ \cdot & \cdot & \cdot & \cdot & \cdot & \cdot & 0 \\ S_{K-2} & \cdot & \cdot & \cdot & \cdot & S_1 & S_0 \\ S_{K-1} & \cdot & \cdot & \cdot & \cdot & S_2 & S_1 \end{bmatrix} \begin{bmatrix} U_2 \\ U_3 \\ \cdot \\ \cdot \\ \cdot \\ U_K \end{bmatrix} + \begin{bmatrix} (1 - \sum_{l=0}^1 S_l)U_0 \\ \cdot \\ \cdot \\ \cdot \\ (1 - \sum_{l=0}^{K-1} S_l)U_0 \end{bmatrix}$$

The above system of linear equation is solved numerically in order to obtain  $U_2, U_3, \dots, U_K$ . Using  $U_2$  and  $U_0$  we can also calculate  $U_1$ . Thus,  $P_{service}^L$ , the probability that a low priority cell will receive service given that it entered the queue is:

$$P_{service}^L = \frac{P_0 + \sum_{i=0}^{K-1} \sum_{j=0}^{K-1-i} P_{i,j} U_{i+j+1}}{P_0 + \sum_{i=0}^{K-1} \sum_{j=0}^{K-1-i} P_{i,j}}$$

### 4.3 Mean waiting time of a low priority cell

Let  $P_0(n, i)$  be the probability that the random walk system reaches absorbing state 0 after exactly  $n$  high priority arrivals given that it starts in state  $i$ . We have

$$\begin{aligned}
 P_0(0, i) &= 1 - \sum_{j=0}^{i-1} S_j \\
 P_0(n, i) &= \sum_{j=2}^{i+1} P_0(n-1, j) S_{i+1-j} \quad \text{for } n \geq 1 \text{ and } 1 \leq i < K \\
 P_0(n, K) &= \sum_{j=2}^K P_0(n-1, j) S_{K+1-j}
 \end{aligned}$$

Let  $N_0(i)$  be the expected number of high priority cells that arrived before the system reached absorbing state 0 given that the system starts in state  $i$ . We get

for  $i = 1, 2, \dots, K-1$ ,

$$\begin{aligned}
 N_0(i) &= \sum_{n=0}^{\infty} n P_0(n, i) \\
 &= \sum_{j=2}^{i+1} \sum_{n=1}^{\infty} n P_0(n-1, j) S_{i+1-j} \\
 &= \sum_{j=2}^{i+1} S_{i+1-j} \left\{ \sum_{n=1}^{\infty} (n-1) P_0(n-1, j) + \sum_{n=1}^{\infty} P_0(n-1, j) \right\} \\
 &= \sum_{j=2}^{i+1} S_{i+1-j} \sum_{n=0}^{\infty} n P_0(n, j) + \sum_{j=2}^{i+1} S_{i+1-j} \sum_{n=0}^{\infty} P_0(n, j) \\
 &= \sum_{j=2}^{i+1} S_{i+1-j} N_0(j) + \sum_{j=2}^{i+1} S_{i+1-j} U_j
 \end{aligned}$$

and

$$\begin{aligned}
 N_0(K) &= \sum_{n=0}^{\infty} n P_0(n, K) \\
 &= \sum_{j=2}^K \sum_{n=1}^{\infty} n P_0(n-1, j) S_{K+1-j} \\
 &= \sum_{j=2}^K S_{K+1-j} \left\{ \sum_{n=1}^{\infty} (n-1) P_0(n-1, j) + \sum_{n=1}^{\infty} P_0(n-1, j) \right\} \\
 &= \sum_{j=2}^K S_{K+1-j} \sum_{n=0}^{\infty} n P_0(n, j) + \sum_{j=2}^K S_{K+1-j} \sum_{n=0}^{\infty} P_0(n, j)
 \end{aligned}$$

$$= \sum_{j=2}^K S_{K+1-j} N_0(j) + \sum_{j=2}^K S_{K+1-j} U_j$$

To find  $N_0(i), i = 1, 2, \dots, K$ , we solve the following linear equations numerically:

$$\begin{aligned} N_0(1) &= S_0 N_0(2) + S_0 U_2 \\ N_0(2) &= S_1 N_0(2) + S_0 N_0(3) + \sum_{j=2}^3 S_{3-j} U_j \\ &\dots \\ &\dots \\ N_0(K-1) &= S_{K-2} N_0(2) + S_{K-3} N_0(3) + \dots + S_0 N_0(K) + \sum_{j=2}^K S_{K-j} U_j \\ N_0(K) &= S_{K-1} N_0(2) + S_{K-2} N_0(3) + \dots + S_1 N_0(K) + \sum_{j=2}^K S_{K+1-j} U_j \end{aligned}$$

Thus,  $\overline{N_0(i)}$ , the expected number of high priority cells that arrive before the tagged low priority cell gets served given that the tagged low priority cell will get served, is:

$$\overline{N_0(i)} = \frac{N_0(i)}{U_i}$$

The mean waiting time of the low priority cell given that it gets served,  $W_L$ , is:

$$W_L = \frac{P_0 x_0 + \sum_{i=0}^{K-1} \sum_{j=0}^{K-1-i} P_{i,j} U_{i+j+1} \left[ \left( \overline{N_0(i+j+1)} + i + j \right) \left( \frac{1}{1-\sigma} \right) + \frac{\sigma}{1-\sigma} + x_0 \right]}{P_0 + \sum_{i=0}^{K-1} \sum_{j=0}^{K-1-i} P_{i,j} U_{i+j+1}}$$

## 5 Approximate analysis of the switch

In this section, we describe a simple approximation algorithm for the analysis of the ATM switch. The approximation algorithm utilizes expression (3) for  $\sigma$ , and the exact results obtained in sections 3 and 4. The algorithm is an iterative scheme. In each iteration we need the cell loss probability for each packet processor queue irrespective of the priority of the lost cell. For efficiency purposes, we calculate this cell loss probability using an algorithm for analyzing a single-class IBP/Geo/1/K+1 queue that was presented in [27].

The iterative approximation algorithm involves the following steps:

**step 0.** Set initial value of the utilization of the  $i$ th cell processor,  $\rho_i^{(0)}, i = 1, 2 \dots N$ .

**step 1.** Compute the probability of retransmission of a cell due to contention in the Clos ATM switch,  $\sigma^{(0)}$ , using expression 3.

**step 2.** Solve the IBP/Geo/1/K + 1 queue with a single class of cells using the solution method in [27] in order to find the probability of cell loss due to the fact that the buffer is full,  $\gamma_K$ .

**step 3.** Compute the utilization of the cell processor,  $\rho_i^{(1)}$  :

$$\rho_i^{(1)} = \frac{\alpha(1-q)}{2-p-q}(1-\gamma_K) \quad , i = 1, 2 \dots N.$$

**step 4.** Use expression 3 to compute  $\sigma^{(1)}$  the probability of retransmission of a cell due to contention in the Clos ATM switch with the new cell processor utilization,  $\rho_i^{(1)}, i = 1, \dots, N$ .

**step 5.** If  $|\sigma^{(1)} - \sigma^{(0)}| < \epsilon$  then  $\sigma = \sigma^{(1)}$  and go to step 6, else set  $\sigma^{(0)} = \sigma^{(1)}$  and go to step 2.

**step 6.** Solve the two-class IBP/Geo/1/K + 1 queue with head-of-line with no preemption and push-out to find the blocking probability of the high priority cell,  $P_{K,0}$ .

**step 7.** Compute the probability that a low priority cell gets served and its mean waiting time.

## 6 Numerical Results

The approximation algorithm described in the previous section was employed to analyze a  $16 \times 16$  bufferless Clos ATM switch. Each switching element was a  $4 \times 4$  crossbar switch. The system size of each cell processor queue was set equal to 32. The arrival process to each cell processor was assumed to be an IBP with  $\alpha = 1$ . That is, during the busy period each slot contains a cell. The approximation results were compared against results obtained by simulation. The results are summarized in figures 7 to 19. Figures 7 to 11 are for a symmetric case, and figures 12 to 19 are for two different asymmetric cases.

In the symmetric case, we assume the same arrival process to each input link with an average arrival rate 0.3. Each arriving cell chooses one of the destination output links uniformly. In figures 7 and 8, we plot the approximate and simulation results for the mean waiting time for high respectively low priority cells as a function of  $\beta$  for various  $C^2$  values. In figure 9, we plot the approximate and simulation results for the probability that a low priority cell gets served given that it entered the queue as a function of  $\beta$  for various  $C^2$  values. The approximate and simulation results for the cell loss probability for low priority cells is given in figure 10 as a function of  $C^2$  for  $\beta$  equal to 0.3. We note that the cell loss probability of the low priority cells comprises the probability a low priority cell will arrive to a full queue and the push-out probability. In Figure 11, we plot the approximate and simulation results for mean waiting time for high and low priority cells as a function of  $C^2$  for  $\beta$  equal to 0.5.

In the results given in figures 7 to 10, the minimum relative error was 1%, the maximum relative error was 15%, and the average relative error was 7%. Most of the approximate results had a relative error less than 5%. The curves given in figures 7 and 8 show how the mean waiting time is affected by  $C^2$  and  $\beta$ . When  $C^2$  is high (i.e. bursty arrivals), the mean waiting time of the low priority cells drops when  $\beta = 0.9$ . This is due to the fact that most of the low priority cells are pushed-out of the buffer by high priority cells. Figure 9 shows how the probability that a low priority cell gets served is affected by the value of  $C^2$  and  $\beta$ . In particular, we note that this probability significantly drops as  $C^2$  increases.

In the two asymmetric cases considered here, the following assumptions were made regarding the arrival processes.

**case 1:**  $\lambda_i = 0.4, i = 1, 2, \dots, 8$  with  $C^2 = 100$ ,  
 $\lambda_i = 0.1, i = 9, 10, \dots, 16$  with  $C^2 = 10$ .

**case 2:**  $\lambda_1 = 0.4, \lambda_{16} = 0.1$ , and the values of the remaining  $\lambda_i$ 's were linearly distributed between 0.4 and 0.1. The value of  $C^2$  was the same for all 16 arrival processes and it was varied from 1 to 500.

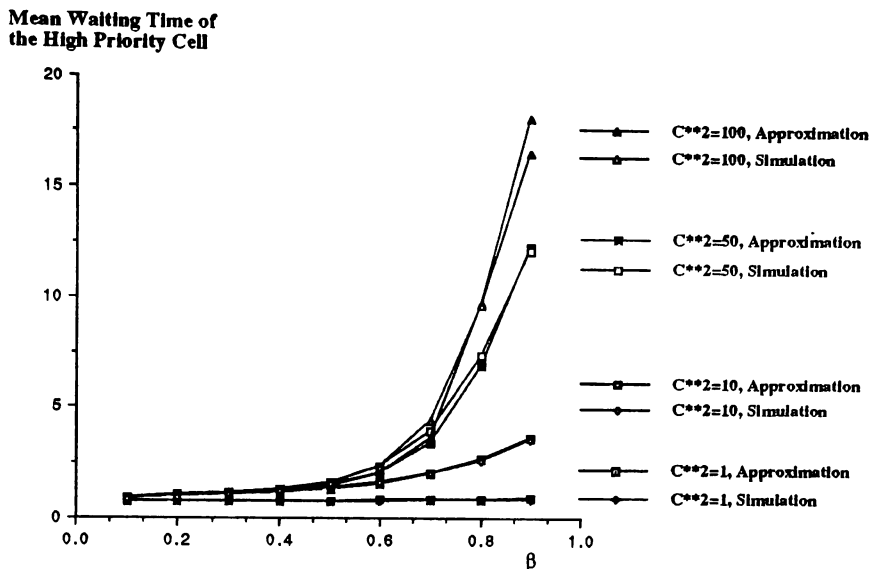

Figure 7: Mean waiting time of the high priority cell; symmetric case.

In both asymmetric cases, it was assumed that each arriving cell chooses one of the destination output lines uniformly.

Figures 12 to 14 are for the asymmetric case 1, and the remaining figures are for the asymmetric case 2. In all the figures we give approximate and simulation results for the most utilized input queue and the least utilized input queue. The relative error of the approximate results is similar to the one observed in the symmetric case discussed above. Finally, we note that the behavior of the performance curves given in these figures is similar to the one observed in the symmetric case.

## 7 Conclusion

In this paper we presented a queueing model of a blocking bufferless synchronous Clos ATM switch with input buffers. The arrival process to each input port was assumed to be bursty and it was modelled by an Interrupted Bernoulli Process. Two classes of cells were considered. The service in each input buffer was head-of-line without preemption. In addition, it was assumed that a high priority cell arriving to a full queue can displace a low priority cell( space preemption). An exact analysis of the input buffer was presented. The results obtained were used in an approximation algorithm for the analysis of the ATM switch. Validation tests using simulation data showed that the approximation algorithm has

**Mean Waiting Time of the Low Priority Cell**

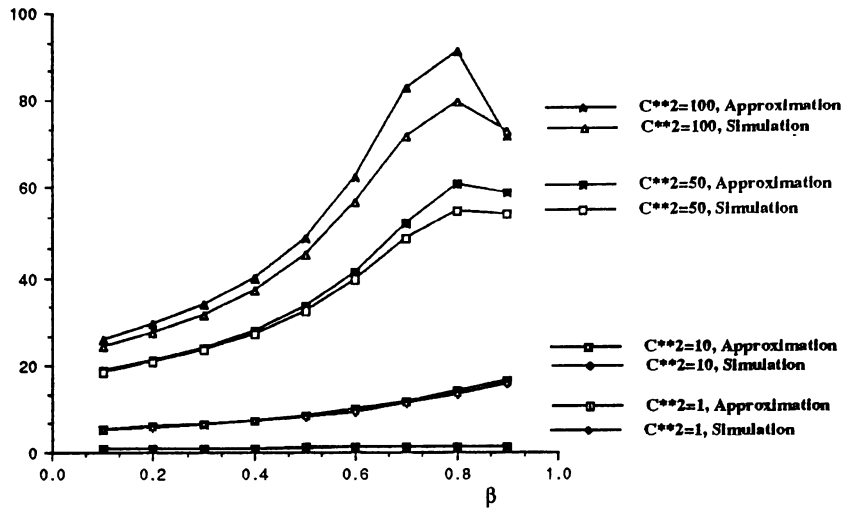

Figure 8: Mean waiting time of the low priority cell; symmetric case.

**Probability that a low priority cell gets served**

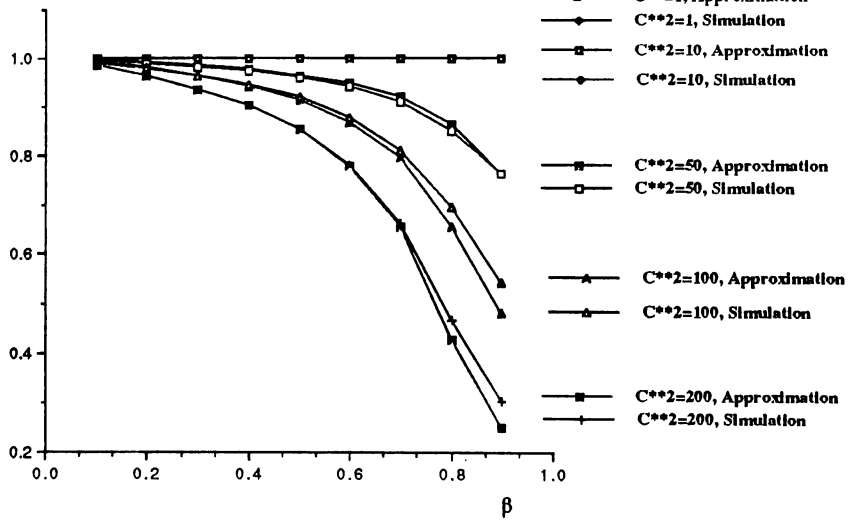

Figure 9: Probability that a low priority cell gets served; symmetric case.

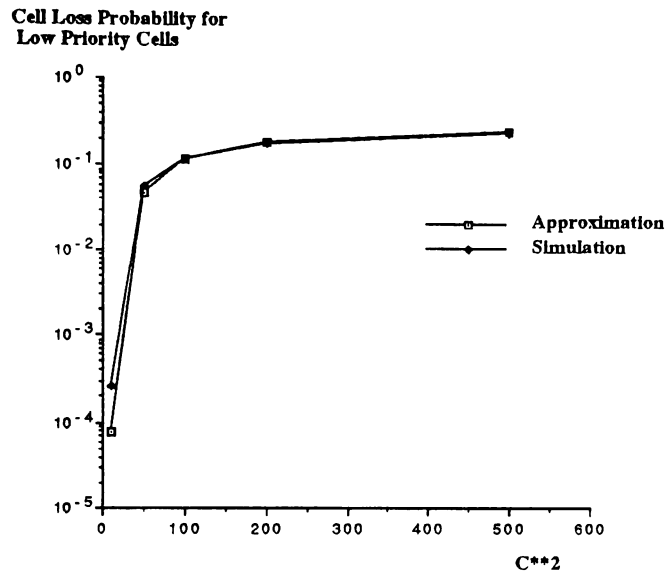

Figure 10: Cell loss probability for low priority cells; symmetric case,  $\beta = 0.3$ .

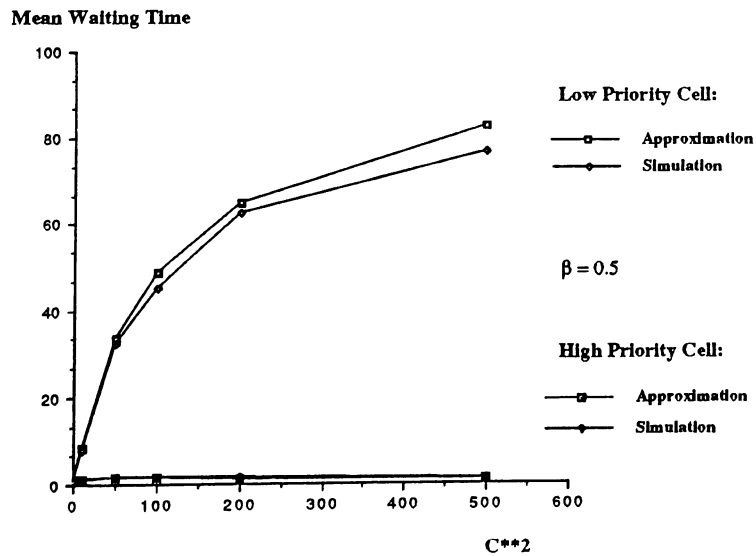

Figure 11: Mean waiting time for low and high priority cells; symmetric case,  $\beta = 0.5$ .



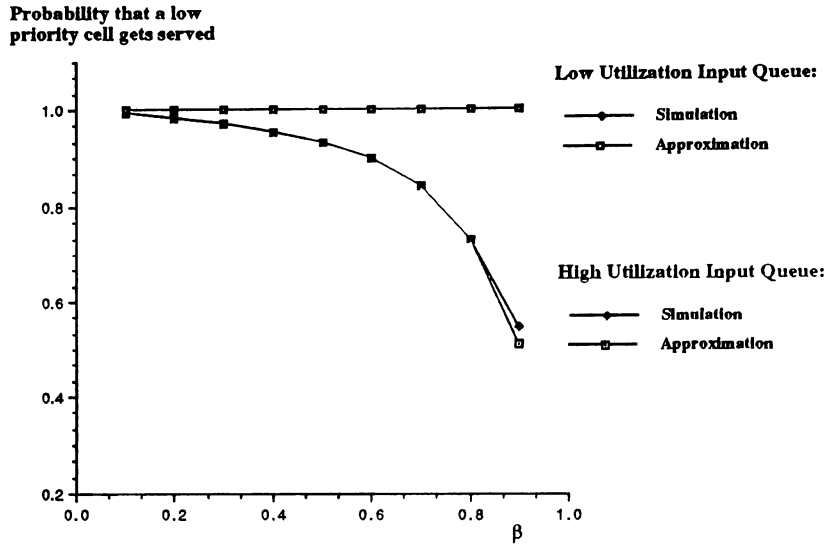

Figure 12: Probability that a low priority cell gets served; asymmetric case 1.

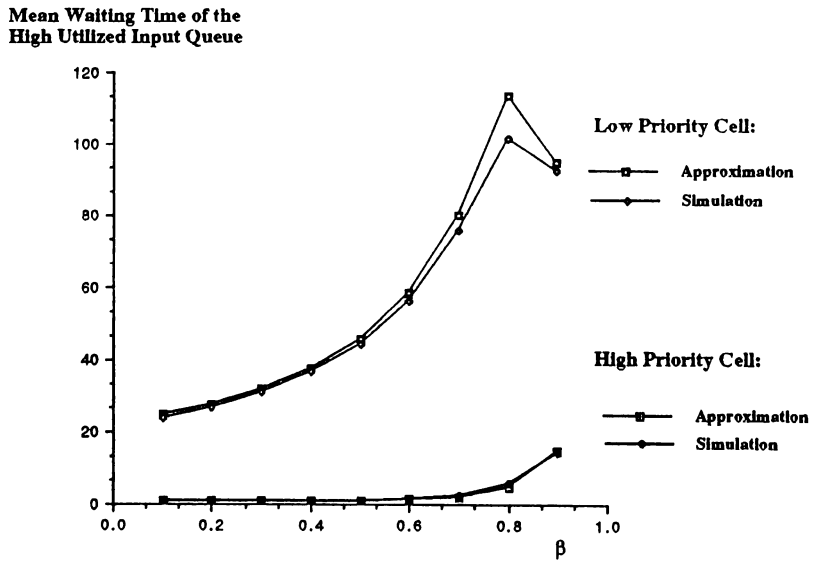

Figure 13: Mean waiting time for the low and high priority cells of the high utilized input queue; asymmetric case 1.

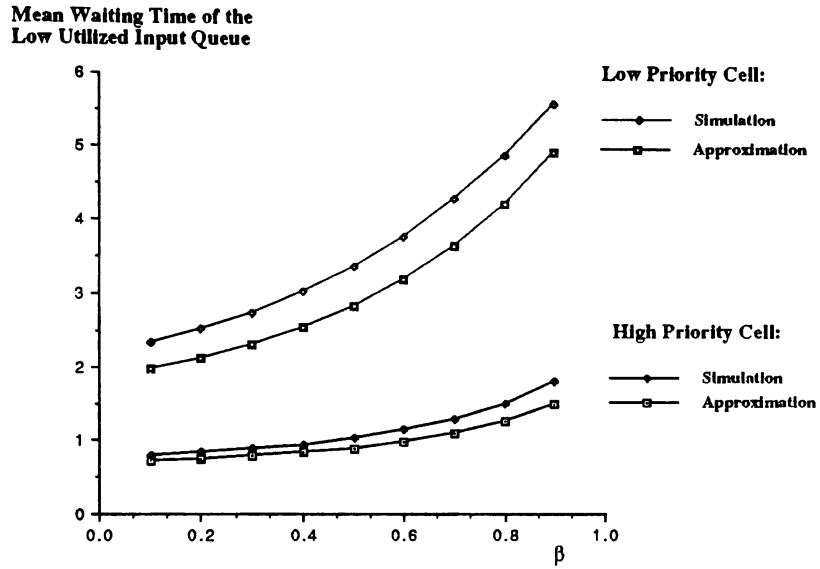

Figure 14: Mean waiting time for the low and high priority cells of the low utilized input queue as a function of  $\beta$ ; asymmetric case 1.

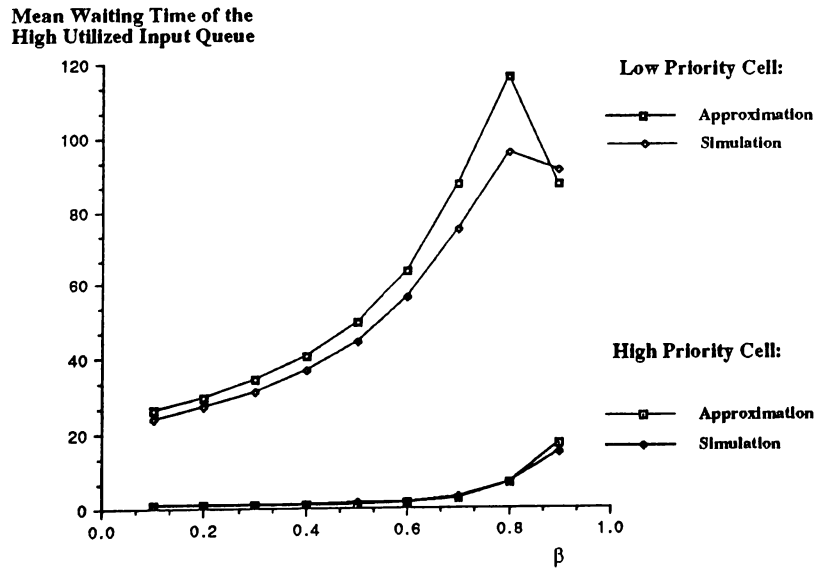

Figure 15: Mean waiting time for the low and high priority cells of the high utilized input queue as a function of  $\beta$ ; asymmetric case 2.

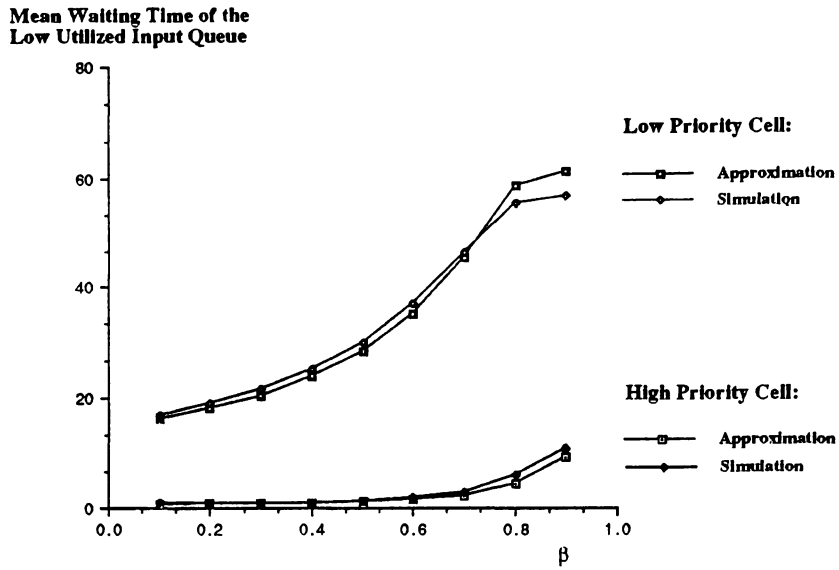

Figure 16: Mean waiting time for the low and high priority cells of the low utilized input queue as a function of  $\beta$ ; Asymmetric case 2.

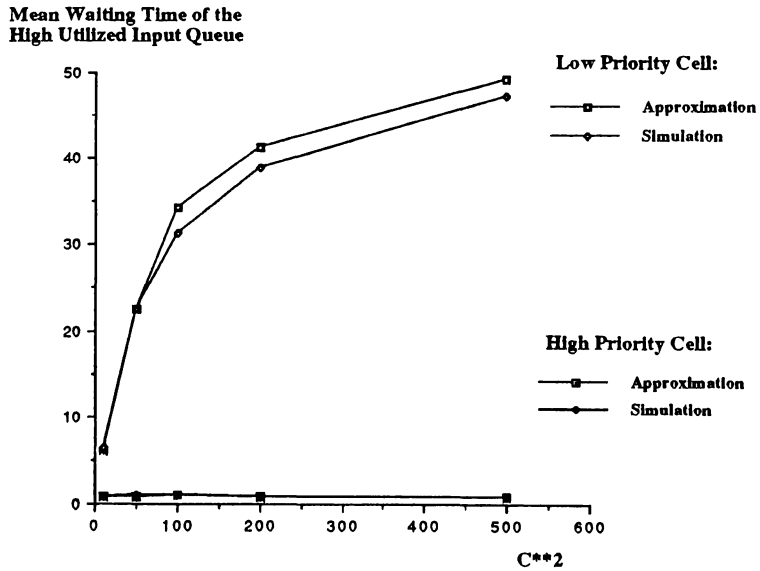

Figure 17: Mean waiting time for the low and high priority cells of the high utilized input queue as a function of  $C^2$  with  $\beta = 0.3$ ; Asymmetric case 2.

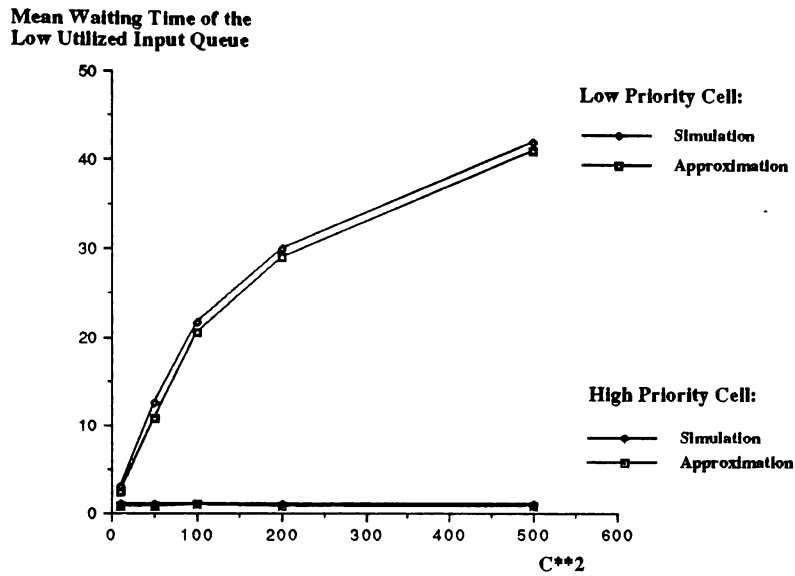

Figure 18: Mean waiting time for the low and high priority cells of the low utilized input queue as a function of  $C^2$  with  $\beta = 0.3$ ; Asymmetric case 2.

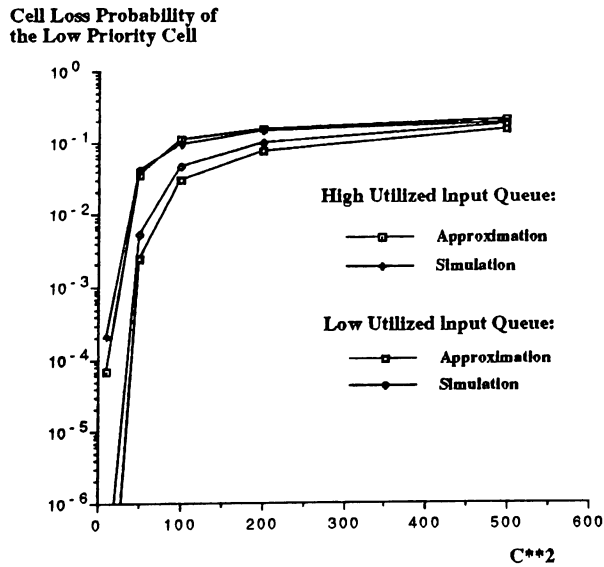

Figure 19: Cell loss probability of the low priority cell; asymmetric case 2.

a good accuracy. Using the analytic techniques developed in this paper, various interesting performance measures such as cell loss probability, mean waiting time, probability that a low priority cell gets served, were obtained.

## References

- [1] J.S. Turner “*Design of a broadcast packet switching network*”, IEEE Trans. Comm., COM-36 (1988) 734-743.
- [2] M.J. Narasimha “*The Batcher-banyan self-routing network: universality and simplification*”, IEEE Trans. Comm., COM-36 (1988) 1175-1178.
- [3] A.Huang and S. Knauer “*Starlite: a wideband digital switch*”, Proc. IEEE GLOBECOM '84 (1984) 121-125.
- [4] J. Giacomelli, M. Littlewood, and W.D. Sincoskie “*Sunshine: a high performance self-routing broadband packet switch architecture*”, Proc. Int. Switch Symp. '90.
- [5] F.A. Tobagi and T. Kwok “*Fast packet switch architectures and the tandem Banyan switching fabric*”, Proc. NATO Advanced Workshop on Architecture and Performance Issues of High-Capacity Local and Metropolitan Area Networks, June 25-27,1990, Sophia-Antipolis, France.
- [6] S. Nojima, E. Tsutsui, H. Fukuda and M. Hashimoto “*Integrated services packet network using bus matrix switch*”, IEEE J. SAC, SAC-5 (1987) 1284-1292.
- [7] Y.-S. Yeh, M. Hluchyj, and A. Acampora “*The knockout switch: a simple, modular architecture for high performance packet switching*”, IEEE J. SAC, SAC-5 (1987) 1274-1283.
- [8] H. Ahmadi, W.E. Denzel, C. A. Murphy, and E. Port “*A high performance switch fabric for integrated circuit and packet switching*”, Proc. INFOCOM '88 (1988) 9-18.
- [9] M. Devault, J.Y. Cochenec, and M. Servel “*The 'Prelude' ATD experiment: assessments and future projects*”, IEEE J. SAC, SAC-6 (1988), 1528-1537. 1528-1537,1988.
- [10] H. Kuwahara, N. Endo, M. Ogino, T. Kozaki “*A shared buffer memory switch for an ATM exchange*”, Proc. Int. Conf. Comm. (1989) 4.4.1-4.4.5.
- [11] H. Suzuki, H. Nagano, and T. Suzuki “*Output-buffer switch architecture for asynchronous transfer mode*”, Proc. Int. Conf. Comm. (1989) 4.1.1-4.1.5.
- [12] F.A. Tobagi “*Fast packet switch architectures for broadband integrated services networks*”, Proc. IEEE 78 (1990) 1133-1167.

- [13] M.J. Karol, M.G. Hluchyj and S.P. Morgan “*Input vs. output queueing on a space-division packet switch*”, IEEE Trans. Comm., COM-35 (1987) 1347-1356.
- [14] M.G. Hluchyj and M.J. Karol “*Queueing in high-performance packet switching*”, IEEE J. SAC, SAC-6, (1988) 1587-1597.
- [15] J. H. Patel “*Performance of Processor-Memory Interconnections for Multiprocessors*”, IEEE Trans. on Comp., COMP-30 (1981) 771-780.
- [16] H. Yoon, K. Lee, and M. Liu “*Performance analysis of multibuffered packet-switching networks in multiprocessor systems*”, IEEE Trans. on Comp., COMP-39 (1990) 319-327.
- [17] S.Z. Shaikh, M. Schwartz, and T.H. Szymanski “*Analysis, control and design of crossbar and banyan based broadband packet switches for integrated traffic*”, IEEE Int. Conf. Comm., VOL. 2 (1990) 761-765.
- [18] Y. Oie, T. Suda, M. Masayuki, and H. Miyahara “*Survey of the performance of non-blocking switches with FIFO input buffers*”, IEEE Int. Conf. Comm., VOL. 2 (1990) 737-741.
- [19] H. Yamashita, H.G. Perros, and S.-W. Hong “*An approximate analysis of the shared buffer switch with bursty arrivals*”, Proc. NATO Advanced Workshop on Architecture and Performance Issues of High-Capacity Local and Metropolitan Area Networks, June 25-27, 1990, Sophia-Antipolis, France.
- [20] J. Garcia and O. Casals, “*Priorities in ATM networks*”, Proc. NATO Advanced Workshop on Architecture and Performance Issues of High-Capacity Local and Metropolitan Area Networks, June 25-27, 1990, Sophia-Antipolis, France.
- [21] J.-Y. Le Boudec “*An efficient solution method for Markov models of ATM links with loss priorities*”, IBM Research Rept. RZ 2001, 1990.
- [22] H. Kröner, G. Hébuterne, P. Boyer, A. Gravey “*Priority management in ATM switching nodes*”, to appear in IEEE Journal on Selected Areas in Communication.
- [23] A. Gravey and G. Hébuterne “*Mixing time and loss priorities in a single server queue*”, Tech. Rept. C.N.E.T, France.
- [24] S. Sumita and T. Ozawa “*Achievability of performance objectives in ATM switching nodes*”, Proc. International Seminar on Performance of Distributed and Parallel Systems, Kyoto, Dec. 1988, 45-56.
- [25] N. Yin, S.-Q. Li and T.E. Stern “*Congestion control for packet voice by selective packet discarding*”, IEEE Trans. Comm., VOL 38 (1990) 674-683.
- [26] H.G. Perros “*Performance issues in ATM networks - A literature review*”, Tech. Rept., Comp. Sci. Dept. North Carolina State Univ., 1990.

- [27] A. A. Nilsson, F.-Y. Lai, and H. G. Perros "An Approximate Analysis of a Bufferless  $N \times N$  Synchronous Clos ATM Switch", *Proceedings, Canadian Conference on Electrical and Computer Engineering*, 39.1.1-39.1.4, 1990.