

Evaluation of the prestress level in Swedish reactor containments

Patrick Anderson¹⁾

1) Department of Structural Engineering, University of Lund, Sweden

ABSTRACT

This paper summarizes a project concerning the prestress level in Swedish reactor containments initiated in year 2002. The overall purpose of this work was to clarify the long-term behaviour and find models to verify the status for large prestressing systems. The work is mainly based on measured tendon force from Swedish in-service inspections and includes three parts. (1) The first part focuses on the technique of measuring tendon force; especially problems involved with friction between tendon and duct are discussed. (2) In the second part results from tendon force measurements available at Swedish power plants are discussed. The different parameters that could influence the measured loss of prestress are evaluated and the loss of prestress is modelled and compared with the result from force measurements. (3) Does the measured tendon force meet the requirements? The third part of the work intend to answer this question by using a reliability-based method.

INTRODUCTION

The prestressing system plays a major role maintaining a high structural integrity of the reactor containments. To avoid through-wall cracks in the concrete the prestress counterbalance the tensile stresses expected in the concrete at an internal accident. The status of the containment is gradually changed due to environmental factors and by alterations in the micro structure of the material. The prestress will be reduced due to shrinkage and creep in the concrete and to relaxation in the tendons (long-term losses). Long-term losses are of a complex nature, with many environmental and material factors involved.

The prestress in the tendons is followed up at regular in-service inspections (ISI) to ensure that the prestress level in the structure is sufficient. To be able to measure the tendon force, the tendons have to be unbonded, i.e. no injection of cement-grout in the space between tendon and duct. Six of the Swedish reactor containments have unbonded tendons. The unbonded tendons are protected from corrosion by grease injection or ventilation by dry air. Both bonded and unbonded tendons are used worldwide. For example in the US almost all tendons are unbonded [1], whereas in France almost all tendons are bonded [2].

During the last three decades an extensive number of force measurements on tendons have been made at Swedish reactor containments (more than 300 tendon measurements). The interpretation of the measuring results is not obvious. Difficulties originates both from uncertainties in the measuring process and from external conditions that varies between different ISI occasions. The measuring results are however unique, since they are performed over a very long time (almost 30 years). The general results from the Swedish measurements show that the mean loss stagnates between 5 and 10% of the original force. This is much lower than the predicted loss at the design stage. Similar results have been experienced by measurements at British containments [3], while measurements from some containments in USA show losses that are higher than predicted [4].

This paper summarizes a project with the overall purpose to clarify the long-term behaviour and find models to verify the status for large prestressing systems. The work is mainly based on measured tendon force from Swedish ISI. The paper is organized in five sections including this introduction. In the next section the general outline of the prestressing system in Swedish containments is described. The following three sections describe the project work including measuring technique, measuring results and required prestress.

SWEDISH REACTOR CONTAINMENTS

The Swedish reactors containments with non cement-injected tendon ducts are located at two different power plants, three pressurized water reactors (PWR) at Ringhals power plant and three boiling water reactors (BWR) at Forsmark power plant.

The Swedish reactor containments are in principle constructed as prestressed concrete cylinders founded on thick concrete plates. The top of the cylinders is either enclosed with a massive steel lid (BWR) or with a prestressed concrete dome (PWR). The cylinder wall consists from the outside of a bearing concrete shell, which is 0.76-1.2m thick and prestressed in two directions (vertically and horizontally). Inside the bearing concrete the steel liner (5-10mm thick) secures the tightness. The inside of the steel liner is protected from missiles (e.g. from pipe pieces) by a 0.26-0.33m thick reinforced concrete shell. Fig 1 shows the principal outline for the containments for

these two types of reactors. It should be noted that all the containments has a large number of penetrations and other discontinuities, not shown in Fig 1.

Two different tendon systems are used for reactor containments in Sweden, BBRV-systems and VSL-systems (see Fig 2). The tendon in BBRV-systems consists of a large number of single wires with fixed length. The tensioning for this system is done by pulling the anchor head backwards. The anchor head is then fixed in the right position with shim plates between the bearing plate and the anchor head. The tendons in the VSL-system consist of a number of strands, which are stretched by pulling directly in the strands. The strands are then fixed with wedges in the anchor head, which have direct contact with the bearing plate. Typical tendons used in Swedish containments are BBRV tendons with 139 wires with diameter of 6 mm (ultimate load, $F_u = 7.1$ MN) and VSL tendons with 19 strands consisting of 7 wires each ($F_u = 3.5$ MN).

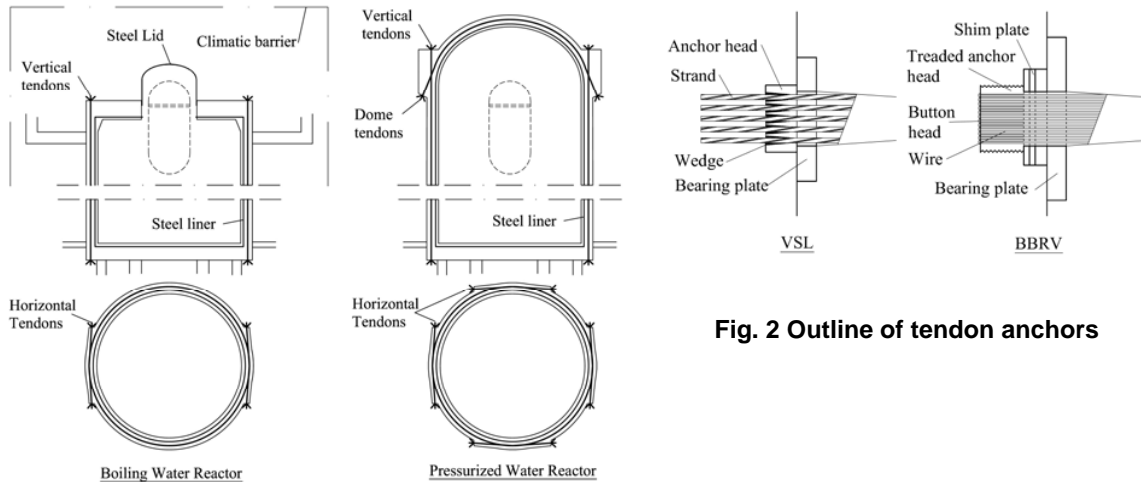

Fig. 2 Outline of tendon anchors

Fig. 1 Outline of Swedish reactor containments

MEASURING OF TENDON FORCE

ISI in Sweden are performed according to an American guide Regulatory Guide 1.35 (1990) [5]. This guide describes the basic methodology of an inspection program for concrete containments with unbonded tendons. The inspections shall be made 1, 3 and 5 years after the structural integrity test and thereafter every 5th year. A reduction of the ISI occasions can be made if there are two or more identical containments at the same power plant. The guide recommends that 4% of the tendons should be selected randomly and tested at each inspection. If the three first ISI shows acceptable results the amount of inspected tendons can be reduced to 2%. Apart from measuring tendon force, one wire or a strand in one of the selected tendons shall be removed and checked over its whole length to observe corrosion or other material defects.

Two different methods for measuring tendon force have been used at Swedish reactor containments. (1) At the ISI occasions so-called lift-off technique is used and (2) at one of the Swedish reactor containments (Forsmark 1) fixed gauges are installed at some of the tendons. Both these methods measure the force in the end of the tendon.

Lift-off technique

Worldwide, lift-off technique is the most common method to measure tendon force [6]. In this method a jack is used to measure the force at the end of the tendon. The intention with the lift-off technique is to measure the force transmitted from the anchor head to the bearing plate (see Fig 3 and 4). In principle, the magnitude of the force is registered at the instant when a movement can be observed between the anchor head and the bearing plate. The most difficult part of the lift-off test is to decide when the anchor head starts to move. The simplest method is to visually observe this. A more sophisticated method is to measure the displacement and force continuously and then define the lift-off force from a curve plot (see Fig 3). The measuring error for the jack equipment is normally stated to max 2%.

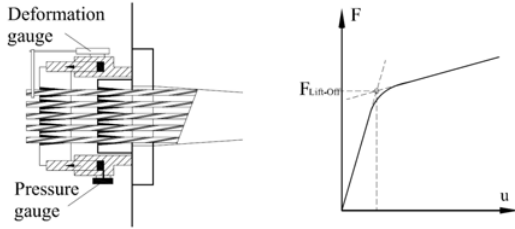

Fig. 3 Lift-off test of VSL-tendon



Fig. 4 Lift-off test in action

Fixed gauges

So-called Glötzl gauges (type K 250 A135) were installed initially on 8 vertical and 5 horizontal tendons (for horizontal at both ends) in Forsmark 1. The force is measured by a pressure ring, which is placed between the anchor and the anchor plate. The force level can be read from a manometer coupled to the pressure ring. The Glötzl gauges have been read approximately every second year and more frequently the first 3 years after the tensioning. The measuring accuracy provided from the manufacturer is 2% for the used gauges.

Influence of friction

All tendons are more or less influenced by friction. In practice even nominally straight tendons are influenced due to wobbling. In Swedish reactor containments it is mainly the horizontal tendons that are influenced by friction. These tendons have in some cases a total bending angle of more than 360°, which results in a maximum friction loss of more than 40%.

For tendons highly influenced by friction, it is concluded in Anderson et al.[7] that force redistribution along the tendon will occur to some extent during the operation time. This redistribution originates generally from discontinuities in the system, like non-uniformly distributed long time losses, temperature changes etc.. The force redistribution tends to equalize the force along the tendon (see Fig 5). This is not a safety problem itself, but the measured force at the end of the tendon will not represent the change of force along the whole tendon. An equalizing towards the average can lead to both increased and decreased end force, depending on the original force distribution. The “hidden” force change can be detected by estimating the average force, using a measuring procedure presented in Anderson et al. [7]. In this procedure the elongation of the tendon is measured when the jack force is increased to a reference level with known force distribution. Test results from the latest ISI at Forsmark 2 shows that the end force has decreased more than the average force for tendons with high influence of friction.

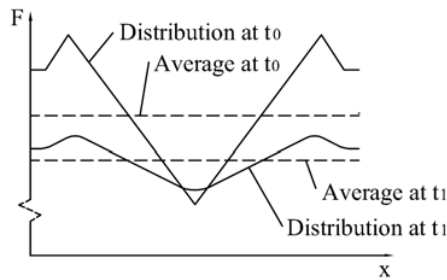

Fig. 5 Force along a tendon at original tensioning (t_0) and after a long time (t_1)

MEASURING RESULTS

This section summarizes the results from all measured tendon force at Swedish reactor containments. The measured tendon force is compared with the modelled force 30 years after the tensioning. Two different models are

used to calculate long-term losses in the concrete, ACI 209 [8] and Model B3 [9]. The relaxation in the tendons is predicted according to recommendations given in PCI Committee of Prestress Losses [10]. The loss from creep and shrinkage in the concrete are added to the loss from relaxation in the steel and compared with the measured force in the figures below. More details about the measuring results and the modelling of prestress are presented in Anderson [11].

Lift-off test

Fig 6 show the measured force at all Swedish ISI divided with the initial measured force. Each break-point represents the mean force from the tested tendons at one ISI occasion. The modeled force 30 years after the initial tensioning is marked with solid dots.

The variability in measured tendon force at each ISI is significant and varies between different ISI. The evaluated coefficient of variation (COV) from Swedish ISI is in the region of 1-8%. VSL tendons (used at Forsmark 1 and 2) show a higher variability than BBRV tendons (used at Ringhals 2-4 and Forsmark 3). The COV for VSL tendons is generally twice as high as for BBRV tendons. Another tendency shown in the measuring results is that COV evaluated from each ISI increases with time. This can be expected due to the variability in the mechanisms of long time losses.

According to Fig 6 the mean of force loss for the Swedish containments lays in general around 5 to 10% of the initial force. In most cases the whole loss seems to arise before the first ISI occasion i.e. 2-5 years after the initial tensioning. The general results from measured force show good agreement with the calculated values according to model ACI 209 and Model B3. The measurements made at Forsmark 2 and Ringhals 2 differs from the rest of the measurements and calculated values.

At Forsmark 2 the losses for the horizontal tendons have increased at every ISI and at the third ISI the measured force was around 20% of the initial force. This force level was confirmed also at the latest ISI at Forsmark 2 (not shown in Fig 6). At this ISI the average force along the tested tendons was measured [7]. As mentioned in the previous section the results from these measurements indicated that the mean loss of force along the tendons was less than the loss of force at the end of the tendon. This could explain the higher losses for the horizontal tendons in Forsmark 2 i.e. the actual average loss could be in agreement with the general result.

For Ringhals 2, both the vertical and the horizontal tendons have higher losses than the general result. The average force along the tendons has not been measured for these tendons. But for the vertical tendons, which not are influenced by friction, this could not explain the higher losses anyway. After comparing Ringhals 2 with other reactor containments, two parameters were detected. One parameter that differs from the rest of the containments is the type of cement used in the containment wall. So-called standard cement was used at Ringhals 2, but for all the other containments slow hardening cement was used. However, no investigations known by the author indicate that this parameter should have a major influence on losses. Another parameter that differs for Ringhals 2 is the time between the tensioning and the start of operation. The temperature increases significantly at the start of operation, and the temperature have been shown to highly influence shrinkage, creep and relaxation. For Ringhals 2 the operation starts already 1 year after the initial tensioning, but for the other containments the operation did not start until 4-5 years after the initial tensioning. The early start for Ringhals 2 is assumed to be the main reason for the larger losses for this containment.

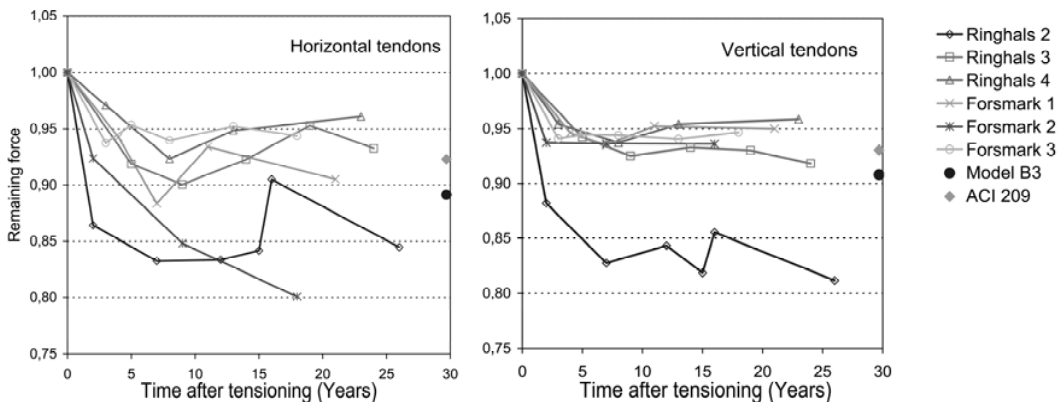

Fig. 6 Lift-off force at Swedish ISI. Each point represents the mean force from the tested tendons at one ISI occasion and each force value is divided with the original force.

Fixed gauges

The results from the fixed gauges at Forsmark 1 are shown in Fig 7 and 8. Unlike the ISI measurements, the results from fixed gauges are measured at the same individual tendons over time. The tendon force are also registered in shorter intervals which makes these results more suitable for indicating trends.

The results from fixed gauges show the same general loss of force as the result from the ISI, i.e. 5-10% average loss of force 25 years after the initial tensioning. The tendon force is assumed to have a linear dependency with a logarithmic timescale. This assumption shows good agreement with the results from the fixed gauges.

In Fig 8 a distinct change of slope can be observed approximately 5 years after the initial tensioning, which is at the same time as the operation of the reactor was started. At this moment, as mentioned before, the temperature was significantly increased (from around 20°C to between 30-45°C). When the temperature rises the relative humidity can be assumed to decrease. Both these factors have been proved to increase longtime losses in the concrete and the tendons. The clearly stated influence of startup at Forsmark 1 increases the validity of the assumption that the early start of Ringhals 2 caused the higher losses found at this containment.

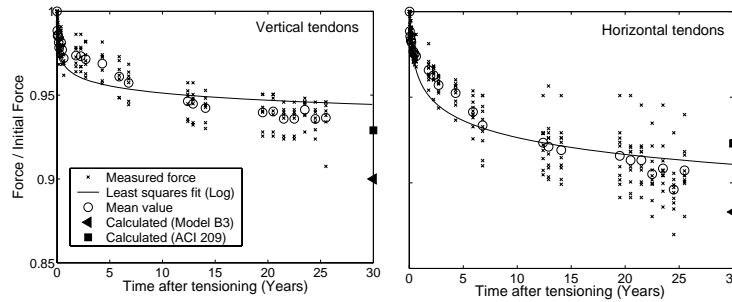

Fig. 7 Measured values from fixed gauges at Forsmark 1 [11]

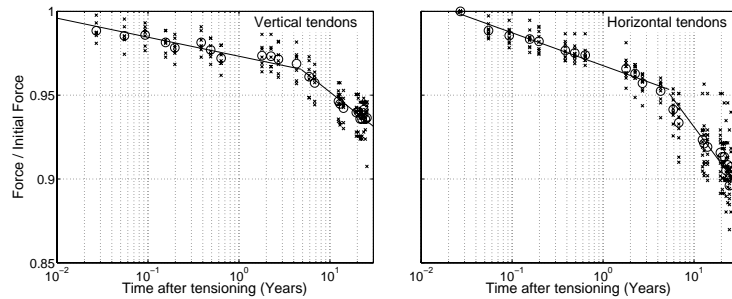

Fig. 8 Measured values from fixed gauges at Forsmark 1 (logarithmic time scale) [11]

REQUIRED PRESTRESS

Existing approaches to evaluate the prestress level (see Regulatory Guide 1.35 [3]) do not take into account the variability in the measured prestress. By using a statistical model, involving the variability in the measuring result and the structural behavior, the prestress level could be confirmed in a more stringent way. A reliability-based method is presented in Anderson et al. [12]. The purpose with this model is to decide if the required prestress level is achieved on the basis of results from ISI. Both the general loss of force (due to time dependent material deformation) and the possibility of one or several tendons being broken (due to corrosion or other material defects) are considered in this model.

To fulfill the requirement of tightness at the internal design pressure the factor of interest is the prestress level in the concrete and not the force in individual tendons. Several tendons influence the prestress level in a specific part of the containment. The required prestress level shall be fulfilled in all parts of the containment where each part is influenced by a number of individual tendons. It is suggested Anderson et al. [12] that this problem can be analyzed as a structural reliability problem idealized as a series of correlated parallel subsystems, briefly described below.

Requirements

According to Swedish requirements the concrete must be in compression state at the internal design pressure (p_d), i.e. tensile stresses resulting from the internal design pressure shall not exceed the prestress. This so called limit state of decompression can be seen as a conservative requirement, since the steel liner will maintain tightness even for loads that gives tensile stresses in the concrete. The main requirement for the prestress level, which refer to the limit state of decompression, can be expressed by the limit state function

$$q(\mathbf{X}) = q_R - q_s \quad (1)$$

where the prestress q_R is a random variable estimated from measured tendon forces. The tensile stress q_s is determined from the internal design pressure. $q(X) > 0$ defines acceptance and $q(X) \leq 0$ a violation of the requirements.

Model

In Anderson et al. [12] it is concluded from lift-off measurements that the tendon force are normally distributed with a mean force μ_F and a standard deviation σ_F . The tendon forces are also concluded to be independent random variables. The prestress in a specific part j of the concrete wall is a sum of a number of influencing tendons which can be seen as parallel coupled

$$q_{R,j} = \sum_{i=1}^N F_i I_{i,j} \quad (2)$$

where N is the total number of tendons, F_i is the force in tendon i and $I_{i,j}$ is the influence factor describing the effect of tendon i on concrete wall part j . Fig 9 show the principals of vertical tendons influence on a part concrete wall.

Assuming that the tendon forces are independent and normally distributed the prestress $q_{R,j}$ will also be normally distributed with a mean $\mu_{q,j}$ and standard deviation $\sigma_{q,j}$ given by

$$\mu_{q,j} = \mu_F \sum_{i=1}^N I_{i,j} \quad (3)$$

$$\sigma_{q,j} = \sigma_F \sqrt{\sum_{i=1}^N I_{i,j}^2} \quad (4)$$

All parts of the containment shall be in compressive state according to the limit state of decompression. This means that the reliability model for the whole structure can be described as a series system of a number of the parallel systems (see Fig 10). The prestress in adjacent structural parts are influenced by a number of the same individual tendons, i.e. the structural parts in the series system have some degree of correlation. The correlation between different structural parts varies depending on the distance between them. This type of unequally correlated series system requires extensive calculations to find the exact probability of violation. An upper bound probability of violation for the whole structure can be found if it is assumed that the elements in the series system are independent.

$$P(q(X) \leq 0) = 1 - \prod_{j=1}^n \left(1 - \Phi \left(\frac{\mu_{q,j} - q_s}{\sigma_{q,j}} \right) \right) \quad (5)$$

This upper bound expression is near the actual probability of violation if the mean correlation is low. In an example in Anderson et al. [12] concerning vertical tendons in a containment structure the correlation is concluded to be low. The probability of violation calculated by a Monte Carlo simulation is shown to be slightly below the upper bound probability, which is expected.

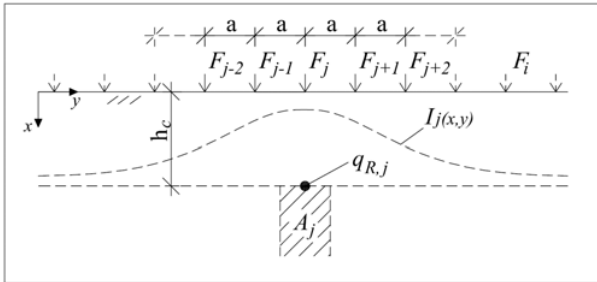

Fig. 9 Vertical tendons influence on a specific part of the containment [12]

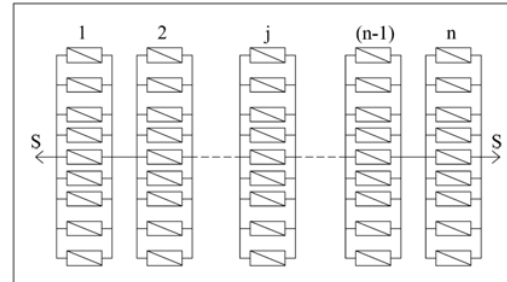

Fig. 10 Series system representing the reliability of the whole structure [12]

SUMMARY AND CONCLUSIONS

The main findings and conclusions from the project concerning the prestress level in Swedish reactor containments are

- For tendons highly influenced by friction the loss of force measured in the end of the tendon is not always representing the general loss of force along the tendon. A method to evaluate the average force along the tendon is presented in Anderson et al.[7]. Measurements at horizontal tendons in the containment of Forsmark 2, show that the loss of average force along the tendons was almost half of the loss of force measured at the end of the tendons.
- The general result from Swedish reactor containments show that the loss of prestress after 30 years is between 5 and 10% of the initial force. This is much less than the loss calculated at the design stage. More advanced models for calculating the loss of prestress available today, show good agreement with the measuring results.
- The temperature surrounding the containments seems to highly influence the loss of prestress. The early start of Ringhals 2, which results in an early elevated temperature, is the most likely reason for the higher loss of prestress found at this containment. The influence of temperature is verified by the results from the fixed gauges at Forsmark. A distinct increase of gradient can be noted when the reactor of Forsmark 1 starts.
- To find out if the measured tendon force meet the requirements a reliability-based method is presented in Anderson et al. [12]. It is suggested that this problem can be analyzed as a structural reliability problem idealized as a series of correlated parallel subsystems.

ACKNOWLEDGEMENT

The research has been financed jointly by the Swedish Nuclear Power Inspectorate (SKI) and the Swedish nuclear power industry (Ringhals AB, Forsmarkskraftgrupp AB and OKG AB). Their support is gratefully acknowledged.

REFERENCES

- [1] Hill, H., Concrete Containment Post Tensioning System Aging Study, Letter Report 95/13 to NRC, Oak Ridge, Tennessee, 1995.
- [2] Martinet, E., Guinet, P., Rousselle, H. and Gragner L., "Prestress losses in NPP containments - The EDF experience", Joint WANO/OECD-NEA Workshop Prestress loss in NPP containments, pp 95-114, Poitiers France, 1997.
- [3] Irving, J., Hinley, M. S. and McCluskey, D., "The measurement of unbonded tendon loads in PCPV an primary containment buildings", Joint WANO/OECD-NEA Workshop Prestress loss in NPP containments, pp 283-313, Poitiers, France, 1997.

- [4] Ashar, H., Costello, J. and Graves, H., "Prestress force losses in containments of U.S. nuclear power plants", Joint WANO/OECD-NEA Workshop Prestress loss in NPP containments, pp 337-351, Poitiers, France, 1997.
- [5] Regulatory guide 1.35, "Inservice Inspection of UngROUTED Tendons in Prestressed Concrete Containments", U.S. Nuclear Regulatory Commission, revision 3, 1990.
- [6] Vives V. and Ubalde L., "Prestressing in Nuclear Power Plants, Anchor Lift-off Measuring System for 37 T 15 Tendons", Joint WANO/OECD-NEA Workshop Prestress loss in NPP containments, pp 221-232, Poitiers, France, 1997.
- [7] Anderson P., Berglund L.E. and Gustavsson J., "Average force along unbonded tendons; a field study at nuclear reactor containments in Sweden", Nuclear Engineering and Design, Vol 235, pp 91-100, 2005.
- [8] ACI Committee 209, "Prediction of creep, shrinkage and temperature effects in concrete structures", ACI 209R-92, pp 1-10, 1992.
- [9] Bazant, Z. P and Murphy, W.P., "Creep and shrinkage prediction model for analysis and design of concrete structures - model B3", Materials and structures, Vol. 28, nr 180, pp 357-365 , 1995.
- [10] PCI Committee of Prestress Losses, Recommendations for estimating prestress losses, Journal of the prestressed concrete institute, Vol. 20, nr 4, pp 44-75, 1975.
- [11] Anderson P., "Thirty years of measured prestress at Swedish nuclear reactor containments". Nuclear Engineering and Design; Vol. 235, pp 2323-2336. , 2005.
- [12] Anderson P., Hansson M. and Thelandersson S. "Reliability-based evaluation of the prestress level in concrete containments with unbonded tendons". Structural Safety, doi:10.1016/j.strusafe.2006.09.003, 2006.