

STUDY OF PRESSURE WAVE PROPAGATION FOR A REACTOR CHANNEL BREAK FOR PHWRs

O.S.Gokhale, D.Mukhopadhyay, H.G.Lele, K.K.Vaze

Reactor Safety Division, Bhabha Atomic Research Centre, Mumbai, INDIA-400085

E-mail of corresponding author: onkarsg@barc.gov.in

ABSTRACT

The Main Heat Transport System (PHTS) of the Indian Pressurized Heavy Water Reactor (PHWR) based 220 MWe Plant consists of reactor channels (306 nos.), feeders, headers, steam generators and circulating pumps. All the reactor channels are submerged in the cold moderator (heavy water) housed in a Calendria Vessel. A reactor channel of 6 m length consists of Pressure Tube (PT), Calendria Tube (CT) and fuel bundles. For a postulated Design Basis Event (DBE) of reactor channel break (PT-CT simultaneous break) also known as In-Core Loss of Coolant Accident in PHWR, the primary side coolant, initially at high temperature, pressure and at sub-cooled condition (90 bar, 270 deg. C), comes in contact with low pressure and low temperature moderator at 1 bar and 65⁰C respectively. Sharp pressure differences present at the interface set up pressure waves in moderator. A numerical estimation of the pressure waves generated, carried out by using safety analysis system computer code RELAP, is reported here. The pressure peaks experienced by the Calendria Vessel have been obtained for double ended pressure tube break inside the Vessel. Maximum pressure seen by the Calendria vessel does not exceed 40 bar near the break location. RELAP5 code specific modelling techniques are studied to ascertain the peak pressure. The generated pressure wave data will be helpful in determining the health of the neighbouring channels.

INTRODUCTION

The 220 MWe Indian Pressurized Heavy Water Reactors consist of a Primary Heat Transport System (PHTS), in a Figure of Eight fashion, having 306 horizontal reactor channels. The reactor channels spanning over length of 6 m contain fuel bundles housed in Pressure Tube (PT) of 90 mm outside diameter. Primary coolant flows through this Pressure Tube at a sub-cooled condition at an average pressure of 90 bars and 270⁰C under normal operating conditions. Each PT is housed in Calendria Tube (CT) of outside diameter 110 mm. The fuel-PT-CT assembly put together forms a reactor channels. 306 such reactor channels are housed in a Calendria Vessel that is filled with moderator (heavy water) maintained at 65⁰C at atmospheric pressure condition. The reactor channels are submerged in the moderator [2].

One of the postulated Design Basis Event (DBE) for assessment of safety of PHWRs is simultaneous break of PT and CT, also called as In-Core LOCA [1]. During such a DBE, the primary coolant at a high pressure of 90 bar and sub-cooled conditions at 270⁰C comes in contact with moderator housed in the Calendria at a pressure of 1 bar maintained at 65⁰C. Sharp gradients of pressure and temperature present near the interface set up pressure waves in the system that travel from the location of PT-CT break towards the Calendria vessel wall at sonic speed determined by the pressure and temperature conditions of the moderator. Sudden pressure release experienced by the primary coolant which is initially at sub-cooled condition causes sudden voiding increasing the pressure in the Calendria Vessel. In this paper, numerical study of generation and propagation of pressure waves is presented. Safety Analysis System code RELAP5 has been used to predict the peak pressure experienced by Moderator.

FLOW MODELS OF RELAP5

The RELAP5/SCDAP code has been developed for best-estimate transient simulation of light water reactor coolant systems during an accident. The code models the coupled behaviour of the reactor coolant system, the core, fission product released during accident transients. The code is based on a non-homogeneous and non-equilibrium model for the two-phase system that is solved by a fast, partially implicit numerical scheme for economical calculation of system transients. Brief description of the flow models used in the code has been given below [3]:

Mass Conservation

The mass conservation equations in the differential form have been given below:

$$\frac{\partial}{\partial t}(\alpha_g \rho_g) + \frac{1}{A} \frac{\partial}{\partial X}(\alpha_g \rho_g V_g A_g) = \Gamma_g \quad (1)$$

$$\frac{\partial}{\partial t}(\alpha_f \rho_f) + \frac{1}{A} \frac{\partial}{\partial X}(\alpha_f \rho_f V_f A_f) = \Gamma_f \quad (2)$$

Momentum Conservation

The basic conservation of momentum equations are given below. A guiding principle used in the development of the RELAP5 momentum formulation is that momentum effects are secondary to mass and energy conservation in reactor safety analysis and a less exact formulation (compared to mass and energy conservation) is acceptable, especially since nuclear reactor flows are dominated by large sources and sinks of momentum (i.e., pumps, abrupt area change). A primary reason for use of the expanded form is that it is more convenient for development of the numerical scheme. The momentum equation for the vapour phase and liquid phase respectively are:

$$\alpha_g \rho_g A \frac{\partial v_g}{\partial t} + \frac{1}{2} \alpha_g \rho_g A \frac{\partial v_g^2}{\partial x} = \left\{ \begin{array}{l} \alpha_g A \frac{\partial P}{\partial x} + \alpha_g \rho_g B_x A - (\alpha_g \rho_g A) FWG(v_g) \\ + \Gamma_g A (v_{gt} - v_g) - (\alpha_g \rho_g A) FIG(v_g - v_f) \\ - C \alpha_g \alpha_f \rho_m A \left[\frac{\partial (v_g - v_f)}{\partial t} + v_f \frac{\partial v_g}{\partial x} - v_g \frac{\partial v_f}{\partial x} \right] \end{array} \right\} \quad (3)$$

$$\alpha_f \rho_f A \frac{\partial v_f}{\partial t} + \frac{1}{2} \alpha_f \rho_f A \frac{\partial v_f^2}{\partial x} = \left\{ \begin{array}{l} \alpha_f A \frac{\partial P}{\partial x} + \alpha_f \rho_f B_x A - (\alpha_f \rho_f A) FWG(v_f) \\ + \Gamma_g A (v_{ft} - v_f) - (\alpha_f \rho_f A) FIG(v_f - v_g) \\ - C \alpha_f \alpha_g \rho_m A \left[\frac{\partial (v_f - v_g)}{\partial t} + v_g \frac{\partial v_f}{\partial x} - v_f \frac{\partial v_g}{\partial x} \right] \end{array} \right\} \quad (4)$$

Energy Conservation

The basic thermal energy equations used in RELAP5 are

$$\frac{\partial}{\partial t}(\alpha_g \rho_g U_g) + \frac{1}{A} \frac{\partial}{\partial x}(\alpha_g \rho_g U_g V_g A) = -P \frac{\partial \alpha_g}{\partial t} - \frac{P}{A} \frac{\partial}{\partial x}(\alpha_g V_g A) + Q_{wg} + Q_{ig} + \Gamma_{ig} h_g + DISS_g \quad (5)$$

$$\frac{\partial}{\partial t}(\alpha_f \rho_f U_f) + \frac{1}{A} \frac{\partial}{\partial x}(\alpha_f \rho_f U_f V_f A) = -P \frac{\partial \alpha_f}{\partial t} - \frac{P}{A} \frac{\partial}{\partial x}(\alpha_f V_f A) + Q_{wg} + Q_{ig} + \Gamma_{ig} h_f + DISS_f \quad (6)$$

RELAP5 CODE SPECIFIC PLANT MODEL

The PHT Model

The RELAP 5 model for the Indian PHWR 220MWe plant is based on RELAP5/Mod 3.2 code. Schematic of the PHT system is shown in Fig. 1. The PHT includes representation of two loops in a figure of eight fashion, reactor channels clubbed into two average channels for each loop, inlet outlet headers, steam generators and associated reactor coolant pumps. Modelling of PHT system has been shown in Fig. 2.

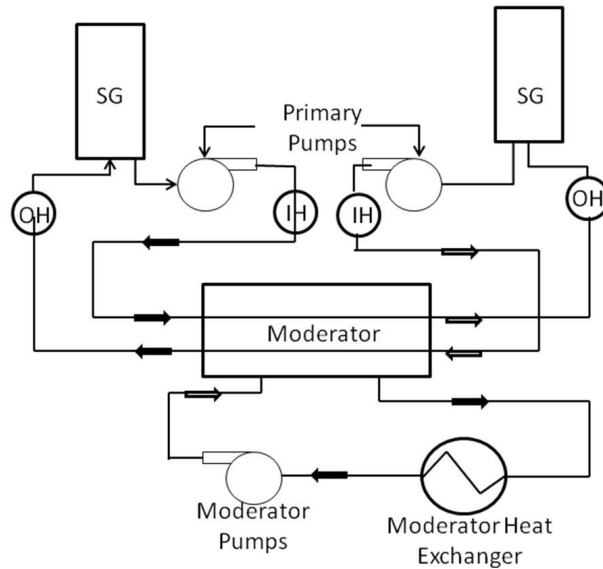

Fig.1: Schematic of Primary Heat Transport System

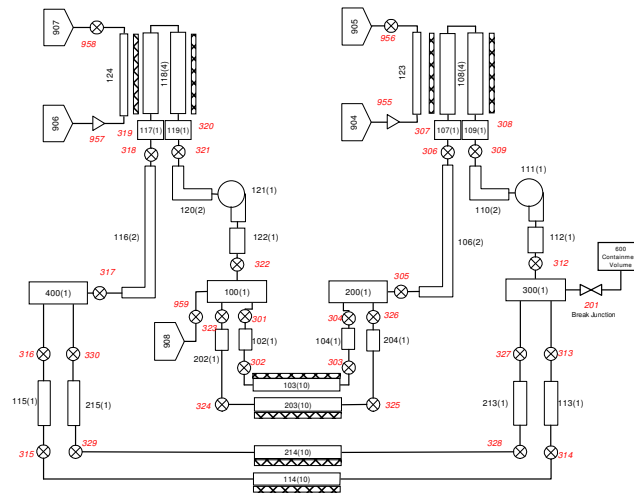

Fig.2: Nodalization of Primary Heat Transport System

Moderator Model

Detailed model for the representation of the moderator contained in the Calendra is developed using RELAP. The 3 D geometry of the moderator can be represented by the pipe components of RELAP5. The radial flow and the axial flow can be treated by solving the momentum equations with momentum flux (normal junction) and without the momentum flux (cross flow junction). To capture the pressure wave propagation in the radial and axial directions the moderator volume was divided into number of sub volumes along the axial as well as radial direction as shown in Fig. 3. These volumes were connected by axial and cross flow junctions to maintain continuity.

Since the models for the cross-flow junction in RELAP do not consider the cross momentum flux while solving the momentum equations, the selection of types of junctions for the radial and axial flow directions was found to affect the predicted pressure propagations characteristics. The schematic of discretization of moderator volumes into axial and radial volumes is shown in Fig. 3 and Fig. 5 respectively. The nodalization of the moderator model has been shown in Fig. 4 and Fig. 6.

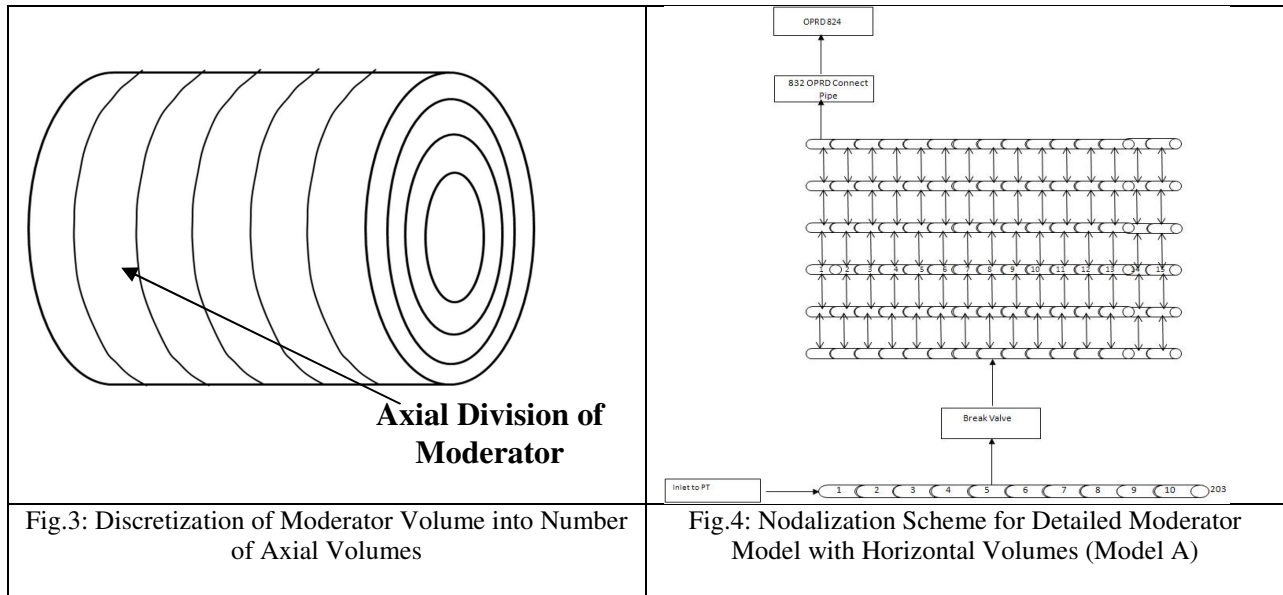

Fig.3: Discretization of Moderator Volume into Number of Axial Volumes

Fig.4: Nodalization Scheme for Detailed Moderator Model with Horizontal Volumes (Model A)

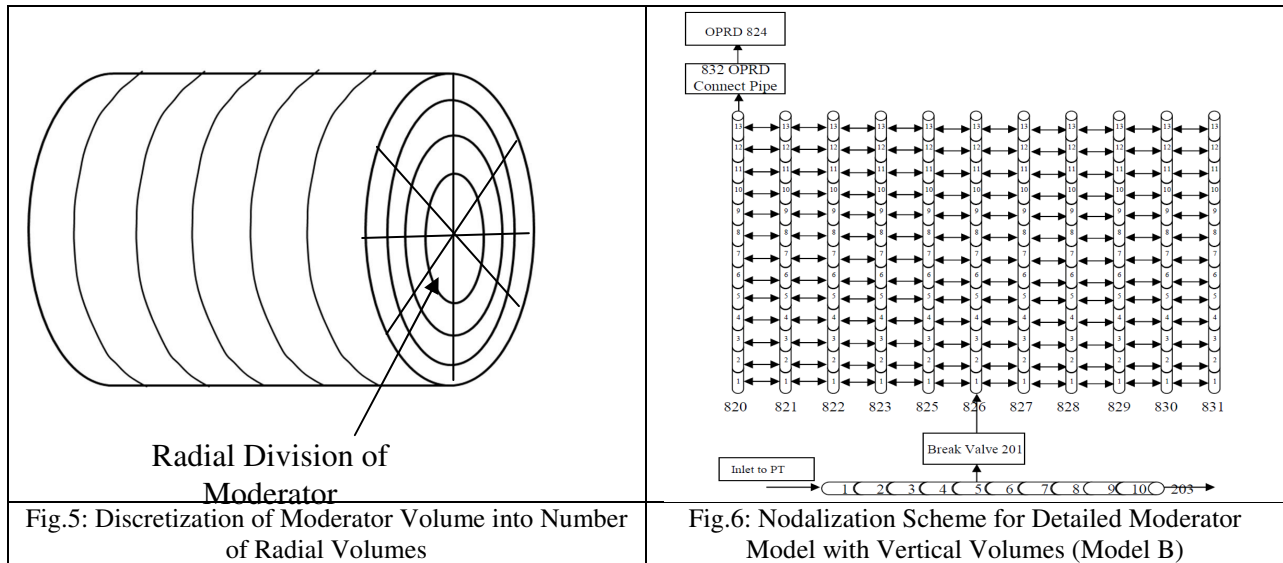

Fig.5: Discretization of Moderator Volume into Number of Radial Volumes

Fig.6: Nodalization Scheme for Detailed Moderator Model with Vertical Volumes (Model B)

Two different modelling techniques are used for modelling the moderator geometry. In the moderator model with horizontal volumes each radial division of the moderator has been modelled as a horizontal pipe (Model A). The junctions between adjacent volumes of a pipe thus become axial flow junctions which have been modelled as normal flow junctions. The flow junctions between corresponding volumes of adjacent pipes have been modelled as cross flow junction as shown in Fig. 4. In the moderator model with vertical volumes (Model B) each of the axial division of the moderator volume has been modelled as a radially outward moving pipe. The junctions between the adjacent volumes of a pipe thus become the radial flow junctions which have been modelled as normal flow junctions between the pipe volumes and again the flow junctions between corresponding volumes of adjacent pipes have been modelled as cross flow junction. The nodalization for this configuration has been shown in Fig. 6. The Over Pressure Rupture Discs (OPRDs) have been modelled as trip valve connected to one of the outermost volumes of the moderator.

PT-CT Rupture Model

The postulated DBE of PT-CT simultaneous rupture is modelled as a break valve connecting one of the primary channels to the moderator volume. A double ended channel rupture has been assumed. A homogeneous critical (choked) flow model has been used at the break location.

RESULTS AND DISCUSSIONS

The steady state corresponding to the normal operating conditions was achieved with the PHWR plant computational model. The In-core LOCA accident was then initiated at a predetermined time by opening of break valve representing a double ended PT-CT break. The Initiating event was also accompanied by reactor trip.

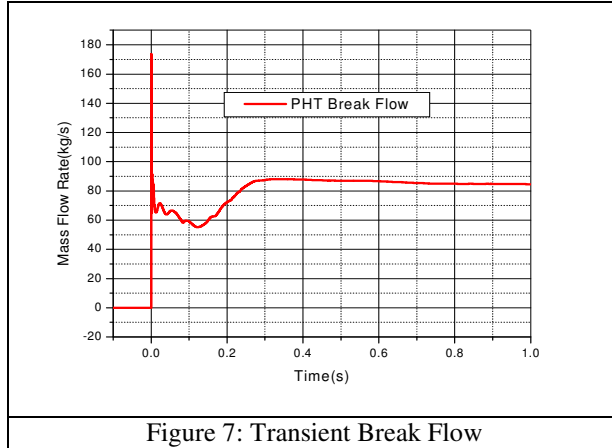

Figure 7: Transient Break Flow

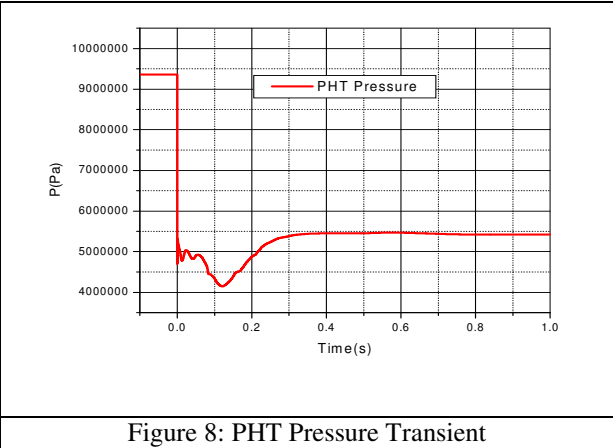

Figure 8: PHT Pressure Transient

The PT-CT rupture initiation causes a sharp peak in the flow rate through the rupture area as shown in Fig. 7. As more and more primary fluid flows out of the break area into the moderator side the flow rate reduces due to pressurization of the moderator side. It increases once again when the OPRD rupture occurs at around 0.1 s relieving the moderator side pressure. The primary side pressure also sees a sharp fall due to sudden opening of break area and then stabilizes at a value of 55 MPa as shown in Fig. 8.

Figure 9 and Fig. 10 show the Pressure transient obtained along a radial line at the location of the break for moderator model with horizontal volumes (Model A) and moderator model with vertical volumes (Model B) respectively. In case of the model with horizontal moderator volumes, the PT CT break junctions as well as the junctions between the corresponding volumes of adjacent pipes are cross flow junction. The cross flow junctions do not consider the momentum flux terms while solving the momentum equations in the direction of the cross flow. Thus the pressure experienced by the moderator volumes (Model A) adjacent to the break is less and the corresponding pressure propagation away from the break in radial direction is also less as compared to the case of moderator model with vertical volumes (Model B).

Since in case of PT-CT rupture the prominent flow direction for the fluid is along the radial direction of the Calandria and not along its axis, the momentum flux terms along the radial flow direction cannot be neglected. The model with vertical moderator volumes models radial flow junctions as normal flow junctions which consider the momentum flux terms and neglect flux momentum along axial directions. The peak pressure in the moderator volume adjacent to the break junction is higher than the one with horizontal moderator volumes of moderator as shown in Fig. 12 and Fig. 11 respectively.

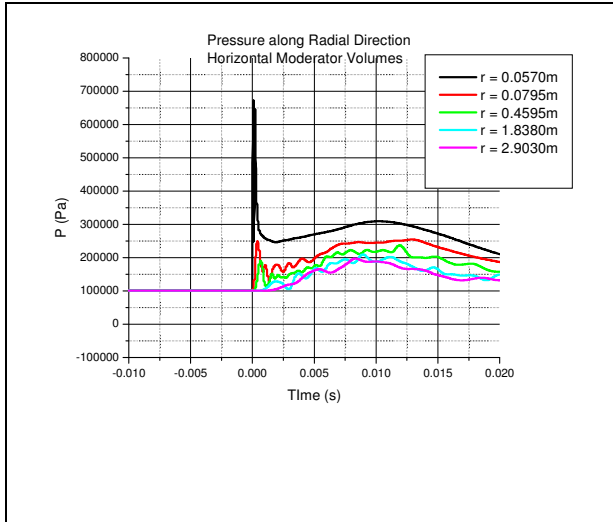

Figure 9: Transient Pressure along Radius for moderator with horizontal volumes (Model A)

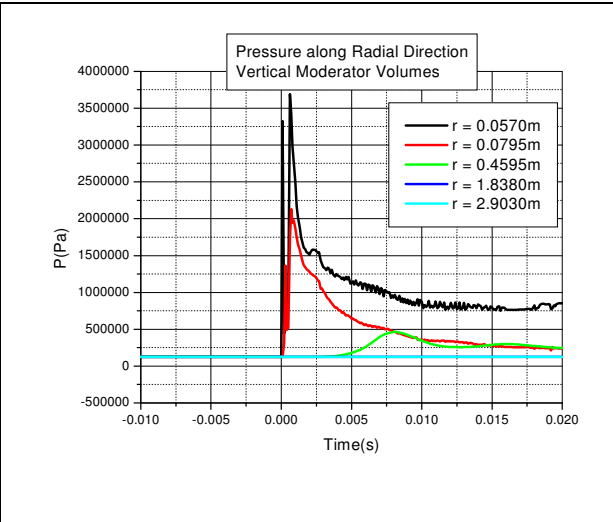

Figure 10: Transient Pressure along Radius for moderator with vertical volumes (Model B)

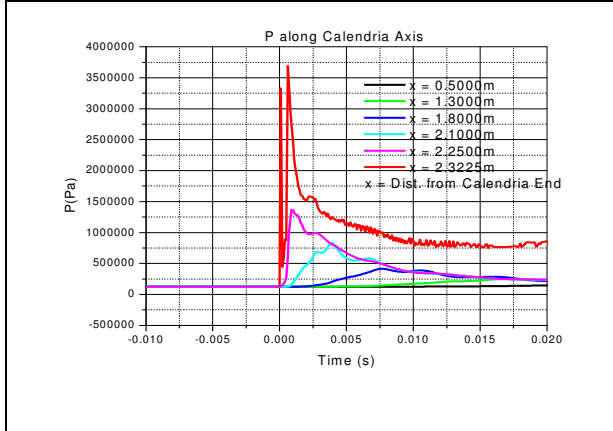

Figure 11: Transient Pressure Along Axis for moderator with horizontal volumes (Model A)

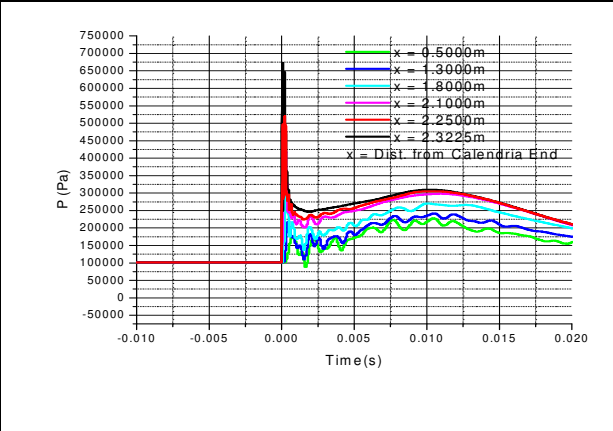

Figure 12: Transient Pressure along Axis for moderator with vertical volumes (Model B)

The pressure wave setup in the moderator volumes travels away from the break in the radial as well as axial direction. The pressure peak in the moderator volume adjacent to the break is instantaneous; however, the peaks in the volumes away from the break occur sequentially with respect to their locations from the break. The peak pressure falls down as the pressure wave loses strength. The maximum pressure seen by the moderator volumes near the Calendra vessel does not exceed 0.7 MPa.

Fig. 13 depicts that the void formation due to sudden depressurization of near saturation primary also propagates away from the break location. As soon as the pressure wave reaches the Calendra vessel, the OPRDs rupture, expelling large amount of moderator out of the Calendra. The flow rate through OPRD has been shown in Fig. 14. The total outgoing energy thus exceeds the total energy coming into the Calendra through the break at time of 0.1 s after the PT-CT rupture (Fig. 15 and Fig. 16). However the pressure in the Calendra vessel tends to rise even after the net energy of the Calendra decreases. This is due to continuous voiding of high temperature primary coolant.

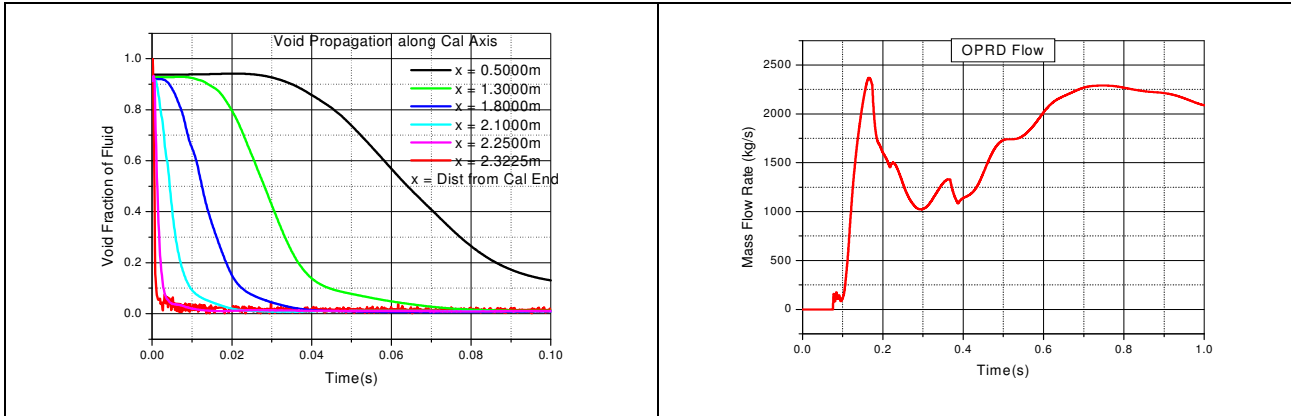

Figure 13: Void Propagation in Moderator Along Axis (Model B)

Figure 14: Transient OPRD Flow (Model B)

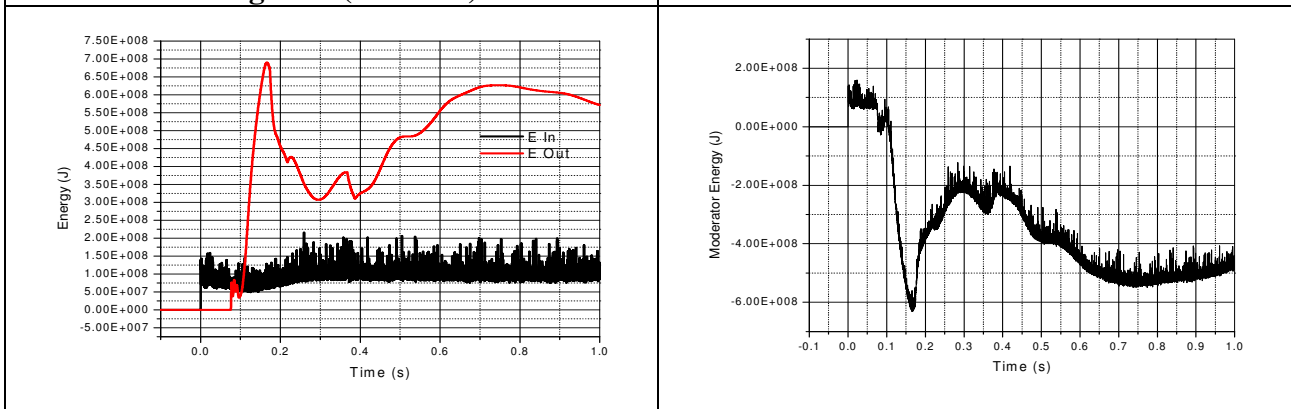

Figure 15: Energy In and Out of the Moderator (Model B)

Figure 16: Net Moderator Energy Transient (Model B)

CONCLUSIONS

The pressure wave is generated due to In Core LOCA in PHWRs due to presence of sharp pressure and temperature difference between the primary coolant and the moderator. As the pressure wave travels away from the break into the moderator region it causes voiding in the moderator region. The strength of the pressure wave decreases with increase in the distance travelled so that the maximum pressure seen by the Calendria Vessel does not exceed 0.7 MPa. Modelling of moderator as vertical volumes connected to each other by cross junctions produces higher peak pressure due to consideration of momentum fluxes in the momentum equation along the dominant flow direction. Also the maximum external pressure seen by the channels adjacent to the channel with PT-CT break does not exceed value of 40 bars.

REFERENCES

[1] Accident Analysis for Nuclear Power Plants with Pressurized Heavy Water Reactors, *IAEA Safety Report Series no. 29*, pp13-36.
 [2] Bajaj, S.S., Gore, A.R., The Indian PHWR, *Nuclear Engineering and Design*, Vol. 236, 2006, pp 701-722.
 [3] RELAP5/MOD3.2 Code Manual, NUREG/CR-5535, INEL-95/0174, June 1995.